

Industrial Roller Chain Products General Catalog

Inspire Series® SBR® Roller Chains

ULTRA-MAX® Roller Chains

HI-MAX® Roller Chains



"The highest rated standard roller chain in the world"

ULTRA-MAX®

"A premium performance solid bushing-solid roller series"

HI-MAX®

"An economical high performance roller chain series"

A Pioneer in the Industrial Chain Business

As a pioneer in the industrial chain business, MAXCO Chain began manufacturing industrial cast chains in 1911 as Tobata Foundry Co. in Japan. In 1956 we became part of the Hitachi Group and in 1972 Hitachi Chain Ltd. was established. The industrial chain business is the foundation on which the company was built and in 1987 when we added our Building Solutions business we became Hitachi Metals Techno, Ltd.

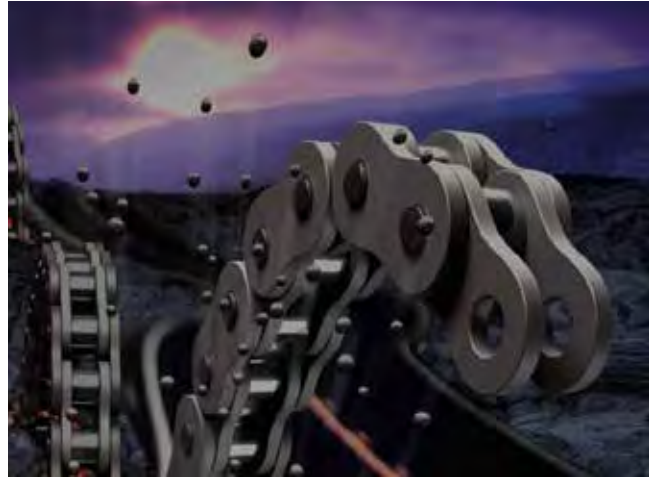

In 2016 the company separated from the Hitachi group to become SENQCIA Corporation. In 2021 the company changed ownership and changed our name to MAXCO Chain. MAXCO Chain supplies industrial roller chain, engineering class chain and wastewater treatment chains and components to North America, Central America, South America and Europe.

Quality Mission

Our INSPIRE SERIES® SBR®/ HKK chains possess the highest-rated working loads in the world. Our popular HI-MAX® brand delivers solid performance at an economical price.

In addition to industrial roller chains, MAXCO Chain manufactures large pitch Engineering Class chain products as well as a full line of chains and components for use in the wastewater treatment industry. Our SAV® stainless steel collector chains are specified in major municipalities throughout North America. In addition, we supply non-metallic chains, sprockets, and other components for use in wastewater treatment facilities.



For more information visit us at
www.maxcochain.com

Corporate Philosophy

MAXCO PHILOSOPHY

Corporate Philosophy

We will contribute to the development of society by providing high quality products and services.

Basic Principles: The Three Promises

1

Pursue uniqueness and strive for technological innovation.

2

Create value from a global perspective.

3

Continue to be a company that all stakeholders can be proud of.

Code of Conduct: "HEAT"

"H" Hospitable: Think from customers standpoint and strive for the best.

"E" Earnest: Act in compliance with social norms.

"A" Active: Think independently and challenge enthusiastically.

"T" Tough: Strive toward goals with persistence.

Inspire Series® SBR® Premium Roller Chains

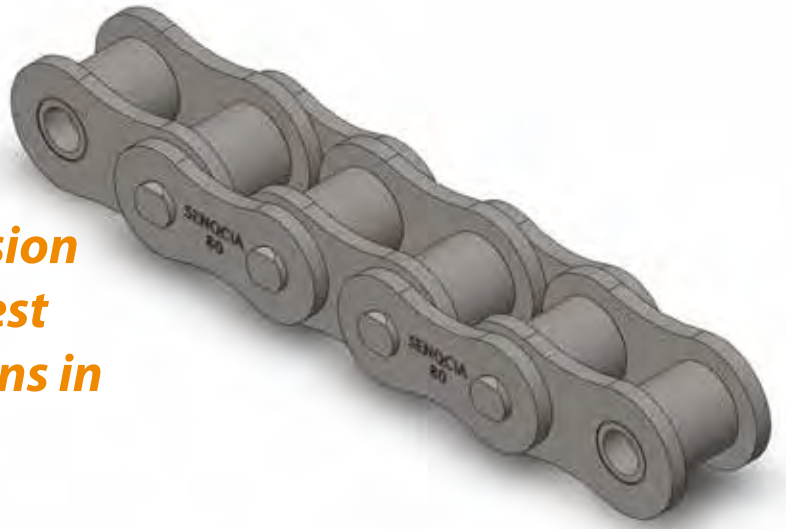

Inspire Series® SBR® precision roller chains are the highest rated standard roller chains in the world.

Patented Mechanical Pin Treatment

This unique process develops a "Triple Zone" hardness on the pin to improve wear resistance and increases fatigue strength substantially from a deep compressive stress zone.

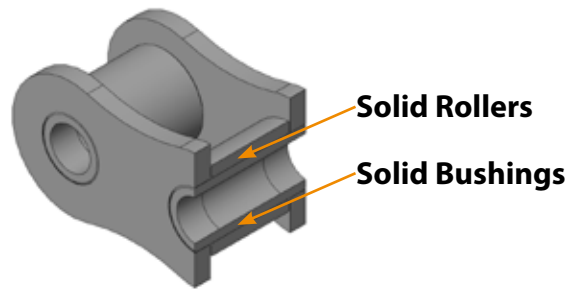
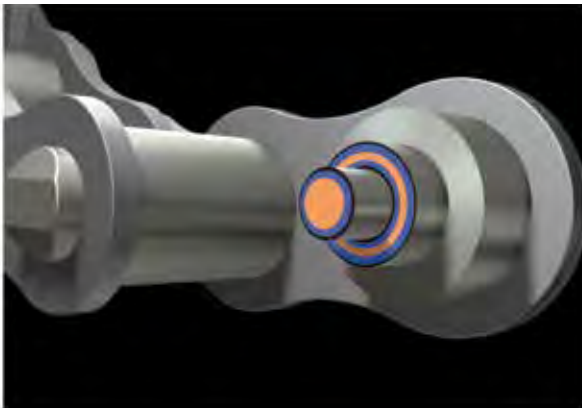

Features Summary:

- Solid bushings and rollers.
- Higher rated working loads.
- Improved wear and abrasion resistance.
- New boron steel pins for most sizes that increase strength and improve ductility.
- Proprietary stainless steel blast for link plates and rollers to protect against rust.
- Unique "Triple Zone" hardness on chain pins.
- Wide Waist Link Plates.
- Redesigned high strength connecting link with flat style closing plates.
- Superior special blend pre-lubricant.

New!

Boron Steel Pins - Increased Strength and Improved Toughness. When combined with our unique processing steps we have achieved the best combination of strength and wear performance available from anyone.

The Ultra-hard shell on the chain pins from our patented mechanical treatment combine with the standard carburized zone to resist wear and abrasion better than before. In addition the new boron steel material is stronger and tougher than before. The result is the best roller chain product we have ever offered!

MAXCO Chain Brand Comparisons

Table of Product Features by Brand

Product Feature	Inspire Series® SBR®	ULTRA-MAX®	Hi-MAX®
Solid Bushings and Rollers	All Sizes except 25 and 41	All Sizes	All Sizes
Bushing/Roller Manufacturing method	6 Station Cold Forming	6 Station Cold Forming	Curling or Barrel Method for Solid Parts
Shot Peening	Yes Standard and Special Shot	Yes Standard Shot	Yes Standard Shot
Patented Mechanical Treatment for Triple Zone Hardening	Yes	No	No
Special Link Plate Coating	Yes Stainless Blast	No	No
Pre-Lubricant	Best	Excellent	Very Good
Rated Working Load	Highest	Very High	High

Working Load Comparison by Size and Brand

ASME/ANSI Chain Number	Inspire Series® SBR®		ULTRA-MAX®		Hi-MAX®	
	Lbs	Kg-f	Lbs	Kg-f	Lbs	Kg-f
25	140	64	140	64	140	64
35	560	255	485	220	475	216
41	500	227	500	227	500	227
40	940	427	815	370	800	364
50	1,625	740	1,400	636	1,350	614
60	2,470	1,125	2,090	950	2,000	909
80	4,295	1,950	3,310	1,505	3,200	1,500
100	6,610	3,005	5,070	2,305	5,000	2,275
120	8,880	4,035	6,830	3,105	6,600	3,000
140	11,750	5,340	9,040	4,110	8,900	4,045
160	15,510	7,050	11,900	5,410	11,500	5,225

Table of Contents

MAXCO Chain Industrial Chain Product	Page
Standard Roller Chains	
General Information	10 - 11
ASME/ANSI Inspire Series® SBR® Roller Chains	12 - 39
Drive Chain Selection	40 - 43
ISO 606B British Standard Roller Chains	44 - 52
CRP Chrome Treated Pin Chains	53
ASME/ANSI Standard Double Pitch Chains	
Transmission Chains	54
Conveyor Series Standard Roller	55
Conveyor Series Large Roller	55
Flat Side Bar Chain	
ASME/ANSI Standard Flat Side Bar Chain	56
ISO 606B Flat Side Bar Chains	57
Extra Capacity Chains	
Heavy (H) Series Roller Chains	58 - 59
Through Hardened Pin (E) Series Roller Chains	60 - 61
Heavy-Through Hardened Pin (HE) Series Roller Chains	62 - 63
ASME/ANSI Super (SU) Series and Super Heavy (HSU) Series Roller Chains	64 - 65
ASME/ANSI Double Capacity Roller Chains	66
ISO 606B British Standard Double Capacity Roller Chains	66
ASME/ANSI Triple and Quad Capacity Roller Chains	67
ISO 606B British Standard Triple and Quad Capacity Roller Chains	67
ASME/ANSI Double Pitch Standard Roller Double Capacity Roller Chains	68
Rollerless Hoist Chains	69
Side Bow (Curved) ASME/ANSI Standard Roller Chains	70
Side Bow (Curved) ASME/ANSI Double Pitch Roller Chains	70
Corrosion and Temperature Resistant Roller Chains	
General Information	71
Nickel Plated Roller Chain	72 - 74
Perfect Coat Plus II® Roller Chain	75 - 78
Stainless Steel Chains General Information	79
Type 304 Series Stainless Steel Roller Chain	80 - 83
Type 600 Series Stainless Steel Roller Chain	84 - 85
Type 316 Series Stainless Steel Roller Chain	86 - 87
Mega Chain Type I and Type II 304 Stainless Steel	88 - 91
Poly Steel (PS) Light Weight Chains	92 - 93
Stainless Steel Corrosion Resistance Guide	94 - 95

Table of Contents

MAXCO Chain Industrial Chain Product	Page
Maintenance Free Roller Chains	
General Information Maintenance Free Roller Chains	96
Standard Self Lube (SL) Series Chains	97 - 98
Freedom Series® Roller Chains	99 - 102
O-Ring Type Sealed Roller Chain	103
Seal Guard® Sealed Type Roller Chains	104 - 105
Hollow Pin Chains	
Carbon Steel Hollow Pin Chains	106 - 107
Stainless Steel Hollow Pin Chains	108 - 109
Self Lube (SL) Type Hollow Pin Chains	109 - 111
Inspire Series® Leaf Chains	
General Information	112
AL Series, BL Series and LL Series Leaf Chains	113 - 117
Inspire Series® SBR® Attachment Chains	
General Information - Nomenclature	118 - 119
ASME/ANSI Standard Attachments Carbon, Stainless and Freedom Series®	120 - 123
ASME/ANSI Double Pitch Attachments Carbon, Stainless and Freedom Series®	124 - 127
ISO 606B Standard Attachments Carbon, Stainless and Freedom Series®	128 - 129
Conveyor Chain Selection	130 - 131
ULTRA-MAX® Series Roller Chains	
ASME/ANSI Standard Chains	132 - 133
ISO 606B British Standard Roller Chains	134 - 135
(H) Series (E) Series and (HE) Series ASME/ANSI Roller Chains	136 - 141
(E) Series ISO 606B British Standard Roller Chain	152 - 143
Double Pitch Roller Chains ASME/ANSI and ISO 606B Series Roller Chains	144 - 145
Flat Side Bar ASME/ANSI and ISO 606B British Standard Roller Chains	146 - 147
HI-MAX® Series Roller Chains	
ASME/ANSI Standard Chains	148 - 149
ISO 606B British Standard Roller Chains	150 - 151
Heavy (H) Series ASME/ANSI Roller Chains	152 - 153
Double Pitch Roller Chains ASME/ANSI Roller Chains	154 - 155
Flat Side Bar ASME/ANSI and ISO 606B British Standard Roller Chains	156 - 157
AL Series, BL Series and LL Series Leaf Chains	158 - 161
Technical Information	
Installation, Lubrication and Maintenance	162 - 165
Drive Configurations	166
Troubleshooting Guide	167
Product Index	168 - 178

General Information

General Dimensions ASME/ANSI Standard Roller Chains

MAXCO Chain Number	ISO Chain Number	Page Number	Units	Chain Pitch	Roller Diameter	Inside Width	Pin Diameter	Roller Link Plate Thickness	Pin Link Plate Thickness	Number of Links in 10ft	Number of Links in 5m
25*	04C-1	12	inch	0.250	0.130	0.125	0.091	0.030	0.030	480	788
			mm	6.35	3.30	3.18	2.31	0.76	0.76		
35*	06C-1	14	inch	0.375	0.200	0.188	0.141	0.050	0.050	320	526
			mm	9.53	5.08	4.78	3.58	1.25	1.25		
41	085-1	16	inch	0.500	0.306	0.250	0.141	0.050	0.050	240	394
			mm	12.70	7.77	6.35	3.58	1.25	1.25		
40	08A-1	18	inch	0.500	0.312	0.313	0.156	0.060	0.060	240	394
			mm	12.70	7.92	7.95	3.96	1.50	1.5		
50	10A-1	20	inch	0.625	0.400	0.375	0.200	0.080	0.080	192	316
			mm	15.875	10.16	9.53	5.08	2.00	2.0		
60	12A-1	22	inch	0.750	0.469	0.500	0.234	0.094	0.094	160	262
			mm	19.05	11.91	12.70	5.95	2.40	2.4		
80	16A-1	24	inch	1.000	0.625	0.625	0.312	0.126	0.125	120	198
			mm	25.40	15.88	15.88	7.93	3.20	3.2		
100	20A-1	26	inch	1.250	0.750	0.750	0.375	0.157	0.157	96	158
			mm	31.75	19.05	19.05	9.53	4.00	4.0		
120	24A-1	28	inch	1.500	0.875	1.000	0.437	0.188	0.188	80	132
			mm	38.10	22.23	25.40	11.10	4.80	4.8		
140	28A-1	30	inch	1.750	1.000	1.000	0.500	0.220	0.220	70	116
			mm	44.45	25.40	25.40	12.70	5.60	5.6		
160	32A-1	32	inch	2.000	1.125	1.250	0.562	0.250	0.250	60	98
			mm	50.80	28.58	31.75	14.28	6.40	6.4		
180	36A-1	34	inch	2.250	1.406	1.406	0.687	0.283	0.283	54	90
			mm	57.15	35.70	35.70	17.45	7.20	7.2		
200	40A-1	36	inch	2.500	1.562	1.500	0.781	0.315	0.315	48	80
			mm	63.50	39.67	38.10	19.83	8.00	8.0		
240	48A-1	38	inch	3.000	1.875	1.875	0.936	0.374	0.374	40	66
			mm	76.20	47.63	47.63	23.78	9.50	9.5		

* Rollerless Chains

How to order standard packaged roller chains:

1. Specify MAXCO Chain or ISO chain number.
2. Specify Type - Riveted or Cotted - Note cotted chains are generally available from 0.750" (19.05mm) pitch and greater.
3. Length - Standard packaging is typically a 10ft box. 5 meter boxes are also available in some regions of the world. Reel stock such as 30ft, 50ft, 100ft, 200ft and 500ft are also available depending on chain size and weight. Contact MAXCO Chain, Ltd. sales personnel for more information.

General Information

General Dimensions ISO 606B British Standard Roller Chains

MAXCO Chain Number	ISO Chain Number	Page Number	Units	Chain Pitch	Roller Diameter	Inside Width	Pin Diameter	Roller Link Plate Thickness	Pin Link Plate Thickness	Number of Links in 10ft	Number of Links in 5m
06B	06B-1	40	inch	0.375	0.250	0.225	0.130	0.050	0.040	320	526
			mm	9.53	6.35	5.72	3.28	1.25	1.00		
08B	08B-1	41	inch	0.500	0.335	0.305	0.175	0.060	0.060	240	394
			mm	12.70	8.51	7.75	4.45	1.5	1.5		
10B	10B-1	42	inch	0.625	0.400	0.380	0.200	0.065	0.065	192	316
			mm	15.875	10.16	9.65	5.08	1.65	1.65		
12B	12B-1	43	inch	0.750	0.475	0.460	0.225	0.070	0.070	160	262
			mm	19.05	12.07	11.68	5.72	1.8	1.8		
16B	16B-1	44	inch	1.000	0.625	0.670	0.325	0.157	0.126	120	198
			mm	25.40	15.88	17.02	8.26	4.0	3.2		
20B	20B-1	45	inch	1.250	0.750	0.770	0.400	0.177	0.138	96	158
			mm	31.75	19.05	19.56	10.16	4.5	3.5		
24B	24B-1	46	inch	1.500	1.000	1.000	0.576	0.232	0.193	80	132
			mm	38.10	25.4	25.4	14.63	5.9	4.9		
28B	28B-1	47	inch	1.750	1.100	1.220	0.625	0.291	0.248	70	116
			mm	44.45	27.94	31.00	15.88	7.4	6.3		
32B	32B-1	48	inch	2.000	1.150	1.220	0.700	0.272	0.248	60	98
			mm	50.80	29.21	31.00	17.81	6.9	6.3		

Chain Construction and Parts



Riveted Chain



Cottered Chain



Multiple Strand Chain



Connecting Link



Offset Link



2 Pitch Offset Link



Roller Link

Riveted Chain: Pins have dual staked rivets on both sides.

Cottered Chains: Pins have dual staked rivets on one side and cotters on the other. Cottered chains are slightly easier to assemble and/or disassemble in the field and are more common on large pitch sizes.

Connecting Links: Used to connect the ends of the chain strand together.

Offset links: Used to shorten or lengthen chain length by one pitch.

2 Pitch Offset Links: Possess slightly greater load carrying capacities than single pitch offsets.

25 ASME/ANSI Roller Chain

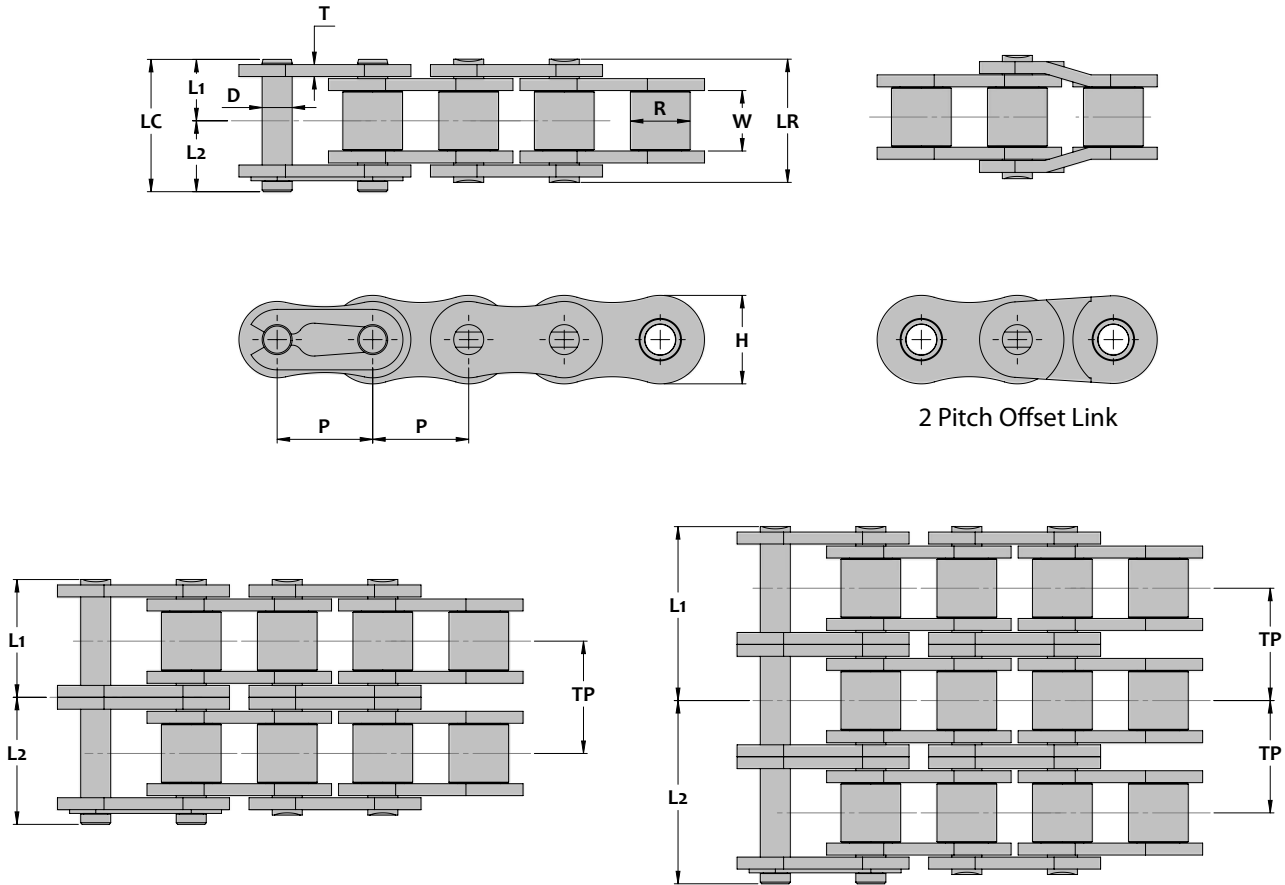

Chain Dimensions

MAXCO Chain Number	Units	Chain Pitch P	Common Dimensions					Roller Link Plate Height H	Number of Links in 10ft/5m	Available Construction	
			Inside Width W	Bushing Diameter R	Pin Diameter D	Link Plate Thickness T	Pin Lengths			Cot	Riv
25	inch	0.250	0.125	0.130	0.091	0.030	0.230	480	No	Yes	
	mm	6.35	3.18	3.30	2.31	0.76	5.84	788			
MAXCO Chain Number	Units	Number of Strands	Pin Lengths				Transverse Pitch TP	Rated Working Load Lbs Kg-f	Average Ultimate Strength Lbs Kg-f	Average Chain Weight Lbs/ft Kg/m	
			L1	L2	LR	LC					
25	inch	1	0.15	0.19	0.30	0.34	-	140	1,050	0.10	
	mm		3.8	4.8	7.6	8.6	-	64	477	0.15	
25-2	inch	2	0.28	0.31	0.56	0.59	0.252	240	2,100	0.19	
	mm		7.1	7.9	14.2	15.0	6.4	109	955	0.28	
25-3	inch	3	0.41	0.45	0.81	0.85	0.252	320	3,150	0.27	
	mm		10.3	11.3	20.6	21.6	6.4	145	1,430	0.40	

35 ASME/ANSI Roller Chain

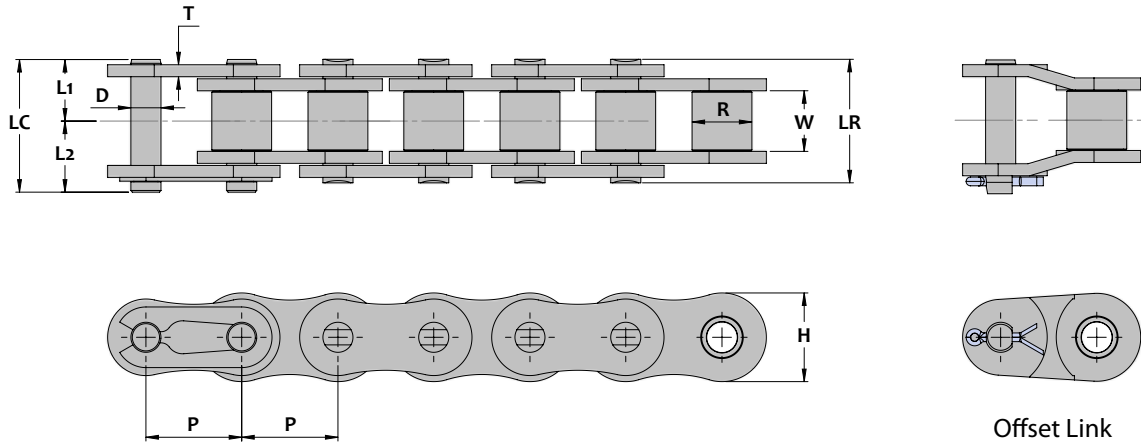

Chain Dimensions

Common Dimensions										
MAXCO Chain Number	Units	Chain Pitch P	Inside Width W	Bushing Diameter R	Pin Diameter D	Link Plate Thickness T	Roller Link Plate Height H	Number of Links in 10ft/5m	Available Construction	
									Cot	Riv
35	inch	0.375	0.188	0.200	0.141	0.050	0.354	320	No	Yes
	mm	9.525	4.78	5.08	3.58	1.25	9.0	526		
Pin Lengths and Chain Ratings										
MAXCO Chain Number	Units	Number of Strands	Pin Lengths				Transverse Pitch TP	Rated Working Load	Average Ultimate Strength	Average Chain Weight
			L1	L2	LR	LC				
35	inch	1	0.24	0.27	0.47	0.51	-	560	2,430	0.23
	mm		6.0	6.9	12.0	12.9	-	255	1,105	0.34
35-2	inch	2	0.44	0.47	0.87	0.91	0.398	840	4,860	0.42
	mm		11.1	11.9	22.2	23.0	10.1	382	2,210	0.63
35-3	inch	3	0.63	0.67	1.27	1.30	0.398	1,230	7,280	0.62
	mm		16.1	17.0	32.2	33.1	10.1	559	3,310	0.92
35-4	inch	4	0.83	0.87	1.67	1.70	0.398	1,620	9,710	0.82
	mm		21.2	22.0	42.4	43.2	10.1	736	4,415	1.22
35-5	inch	5	1.03	1.06	2.06	2.09	0.398	1,910	12,140	1.05
	mm		26.2	27.0	52.4	53.2	10.1	868	5,520	1.56
35-6	inch	6	1.23	1.27	2.46	2.50	0.398	2,250	14,570	1.27
	mm		31.3	32.2	62.6	63.5	10.1	1,025	6,620	1.89

41 ASME/ANSI Roller Chain

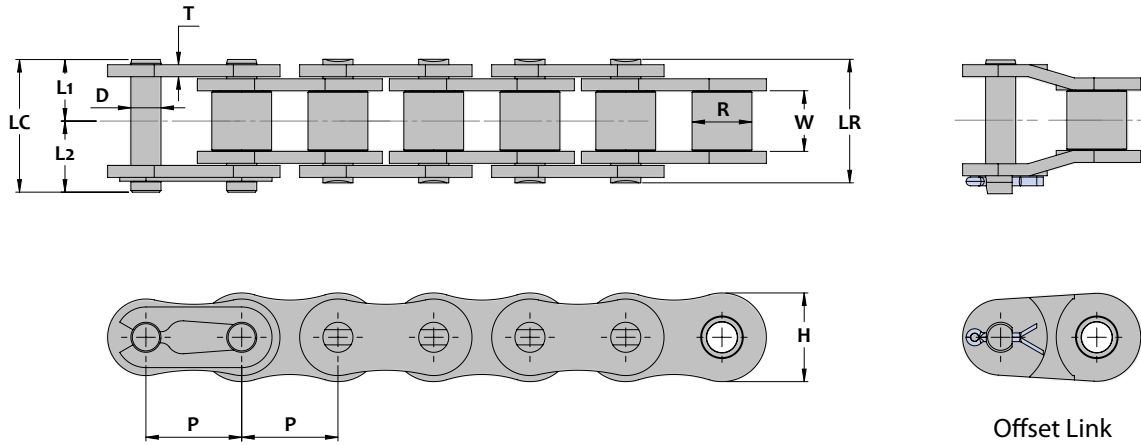

Chain Dimensions

Common Dimensions										
MAXCO Chain Number	Units	Chain Pitch P	Inside Width W	Roller Diameter R	Pin Diameter D	Link Plate Thickness T	Roller Link Plate Height H	Number of Links in 10ft/5m	Available Construction	
									Cottered	Riveted
41	inch	0.500	0.250	0.306	0.141	0.050	0.382	240	No	Yes
	mm	12.70	6.35	7.77	3.58	1.25	9.7	394		
Pin Lengths and Chain Ratings										
MAXCO Chain Number	Units	Number of Strands	Pin Lengths				Transverse Pitch TP	Rated Working Load Lbs Kg-f	Average Ultimate Strength Lbs Kg-f	Average Chain Weight Lbs/ft Kg/m
			L1	L2	LR	LC				
41	inch	1	0.26	0.31	0.52	0.57	-	500	2,600	0.30
	mm		6.6	7.9	13.2	14.5	-	227	1,180	0.45

40 ASME/ANSI Roller Chain

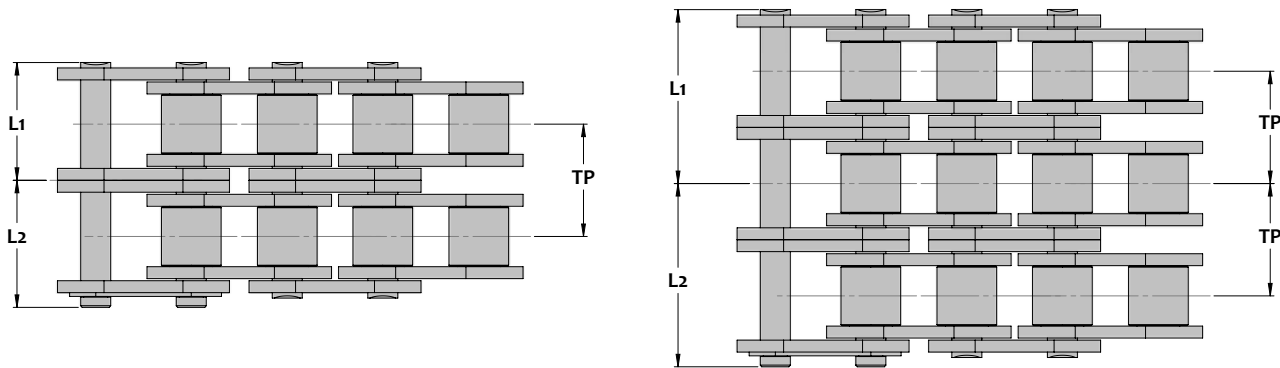
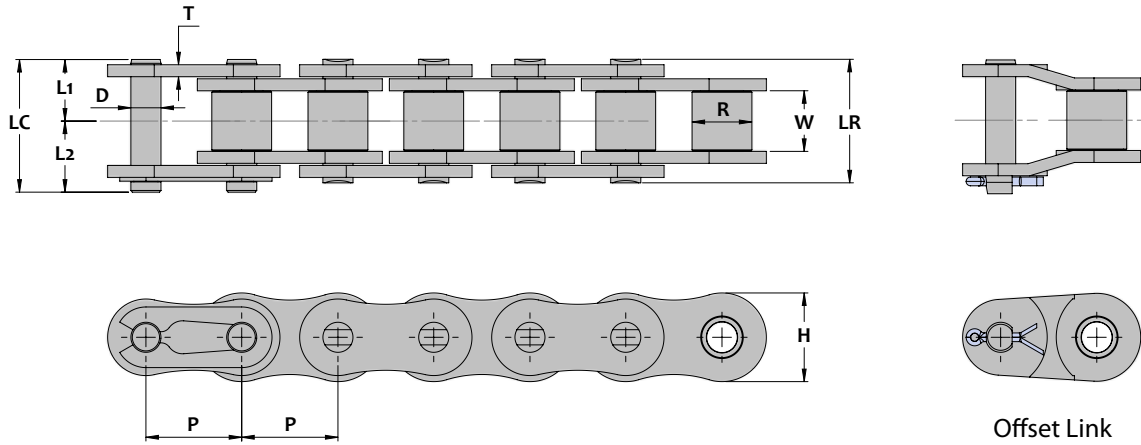

Chain Dimensions

Common Dimensions										
MAXCO Chain Number	Units	Chain Pitch P	Inside Width W	Roller Diameter R	Pin Diameter D	Link Plate Thickness T	Roller Link Plate Height H	Number of Links in 10ft/5m	Available Construction	
40	inch mm	0.500 12.70	0.313 7.95	0.312 7.92	0.156 3.96	0.060 1.5	0.461 11.7	240 394	Cottered No	Riveted Yes
Pin Lengths and Chain Ratings										
MAXCO Chain Number	Units	Number of Strands	Pin Lengths				Transverse Pitch TP	Rated Working Load	Average Ultimate Strength	Average Chain Weight
			L1	L2	LR	LC				
40	inch mm	1	0.33 8.3	0.38 9.6	0.65 16.6	0.70 17.9	- -	940 427	4,300 1,955	0.40 0.60
40-2	inch mm	2	0.61 15.4	0.66 16.8	1.21 30.8	1.27 32.2	0.567 14.4	1,400 636	8,600 3,910	0.82 1.22
40-3	inch mm	3	0.89 22.5	0.95 24.1	1.77 45.0	1.83 46.6	0.567 14.4	2,050 932	12,900 5,865	1.24 1.85
40-4	inch mm	4	1.18 30.0	1.21 30.8	2.36 60.0	2.39 60.8	0.567 14.4	2,700 1,225	17,200 7,820	1.65 2.46
40-5	inch mm	5	1.47 37.3	1.51 38.3	2.94 74.6	2.98 75.6	0.567 14.4	3,200 1,455	21,500 9,775	2.11 3.14
40-6	inch mm	6	1.75 44.5	1.79 45.4	3.50 89.0	3.54 89.9	0.567 14.4	3,770 1,715	25,800 11,725	2.22 3.31

50 ASME/ANSI Roller Chain

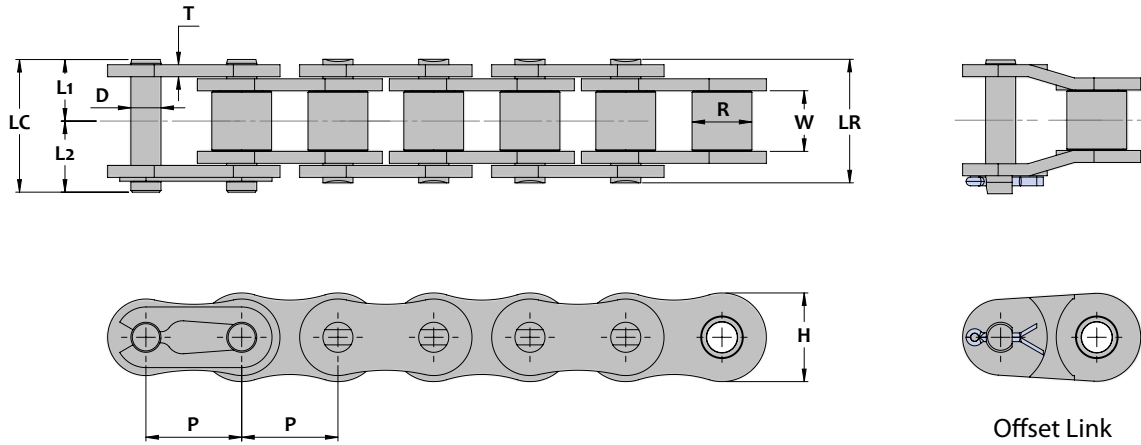

Offset Link

Chain Dimensions

Common Dimensions										
MAXCO Chain Number	Units	Chain Pitch P	Inside Width W	Roller Diameter R	Pin Diameter D	Link Plate Thickness T	Roller Link Plate Height H	Number of Links in 10ft/5m	Available Construction	
50	inch mm	0.625 15.875	0.375 9.53	0.400 10.16	0.200 5.08	0.080 2.0	0.575 14.6	192 316	Yes	Yes
Pin Lengths and Chain Ratings										
MAXCO Chain Number	Units	Number of Strands	Pin Lengths				Transverse Pitch TP	Rated Working Load	Average Ultimate Strength	Average Chain Weight
			L1	L2	LR	LC				
50	inch	1	0.40	0.46	0.80	0.87	-	1,625	7,200	0.66
	mm		10.2	11.8	20.4	22.0	-	740	3,275	0.98
50-2	inch	2	0.76	0.82	1.51	1.57	0.712	2,430	14,400	1.34
	mm		19.2	20.8	38.4	40.0	18.08	1,105	6,545	2.00
50-3	inch	3	1.12	1.17	2.23	2.29	0.712	3,580	21,600	2.06
	mm		28.4	29.8	56.7	58.2	18.08	1,625	9,820	3.07
50-4	inch	4	1.48	1.50	2.95	2.98	0.712	4,720	28,800	2.66
	mm		37.5	38.2	75.0	75.7	18.08	2,145	13,090	3.97
50-5	inch	5	1.83	1.87	3.67	3.70	0.712	5,580	36,000	3.37
	mm		46.6	47.5	93.2	94.1	18.08	2,535	16,365	5.02
50-6	inch	6	2.19	2.24	4.39	4.43	0.712	6,580	43,200	4.03
	mm		55.7	56.8	111.4	112.5	18.08	2,990	19,635	6.01

60 ASME/ANSI Roller Chain

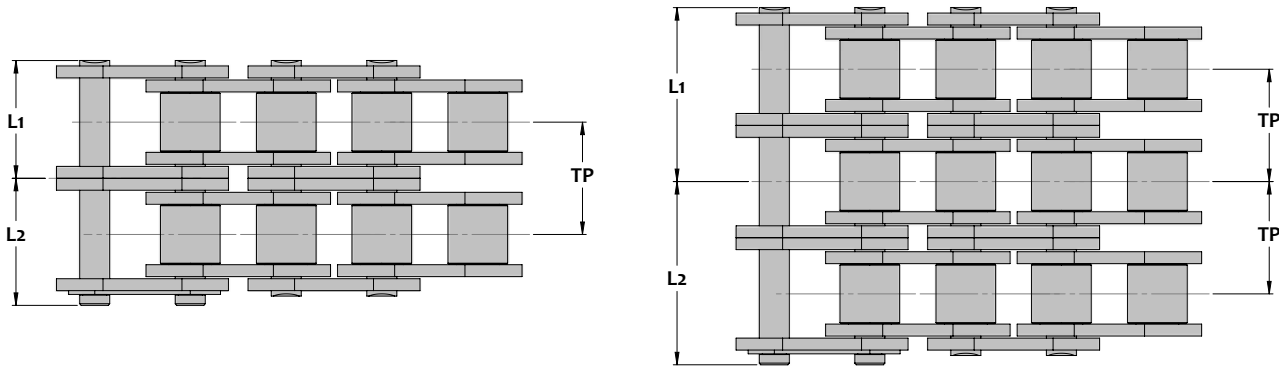
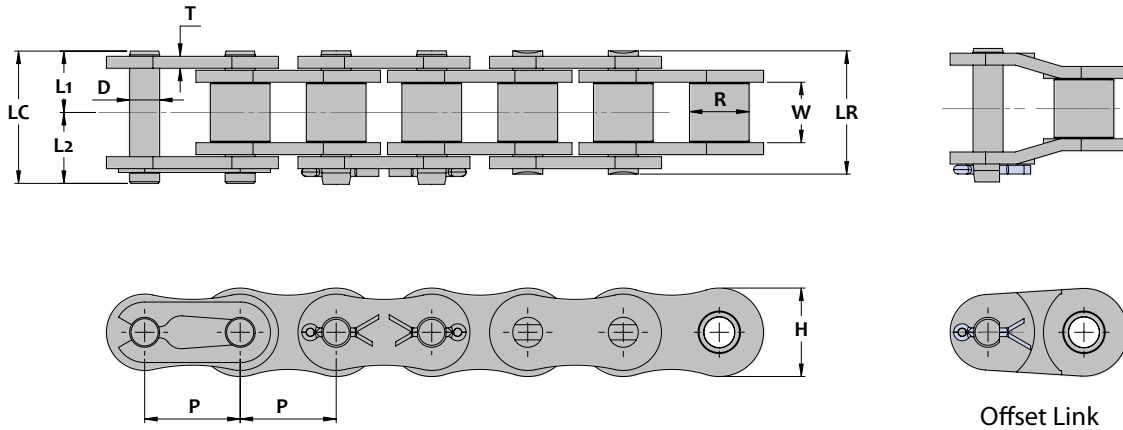

Chain Dimensions

MAXCO Chain Number	Units	Chain Pitch P	Common Dimensions						Available Construction	
			Inside Width W	Roller Diameter R	Pin Diameter D	Link Plate Thickness T	Roller Link Plate Height H	Number of Links in 10ft/5m	Cottered	Riveted
60	inch	0.750	0.500	0.469	0.234	0.094	0.689	160	Yes	Yes
	mm	19.05	12.70	11.91	5.95	2.4	17.5	262		

MAXCO Chain Number	Units	Number of Strands	Pin Length				Transverse Pitch TP	Rated Working Load Lbs Kg-f	Average Ultimate Strength Lbs Kg-f	Average Chain Weight Lbs/ft Kg/m
			L1	L2	LR	LC				
			60	inch	1	0.50				
	mm	12.8	14.1	25.5		26.9	-	1,125	4,545	1.46
60-2	inch	2	0.94	1.01	1.90	1.96	0.898	3,370	19,800	1.98
	mm		24.0	25.7	48.2	49.7	22.8	1,530	9,000	2.95
60-3	inch	3	1.39	1.47	2.80	2.86	0.898	4,950	29,700	2.97
	mm		35.2	37.4	71.2	72.6	22.8	2,250	13,500	4.43
60-4	inch	4	1.86	1.90	3.72	3.76	0.898	6,530	39,600	3.97
	mm		47.2	48.2	94.4	95.4	22.8	2,970	18,000	5.92
60-5	inch	5	2.30	2.35	4.61	4.65	0.898	7,720	49,500	4.97
	mm		58.5	59.7	117.0	118.2	22.8	3,510	22,500	7.41
60-6	inch	6	2.76	2.79	5.51	5.55	0.898	9,100	59,400	5.97
	mm		70.1	70.8	140.0	140.9	22.8	4,135	27,000	8.90

80 ASME/ANSI Roller Chain

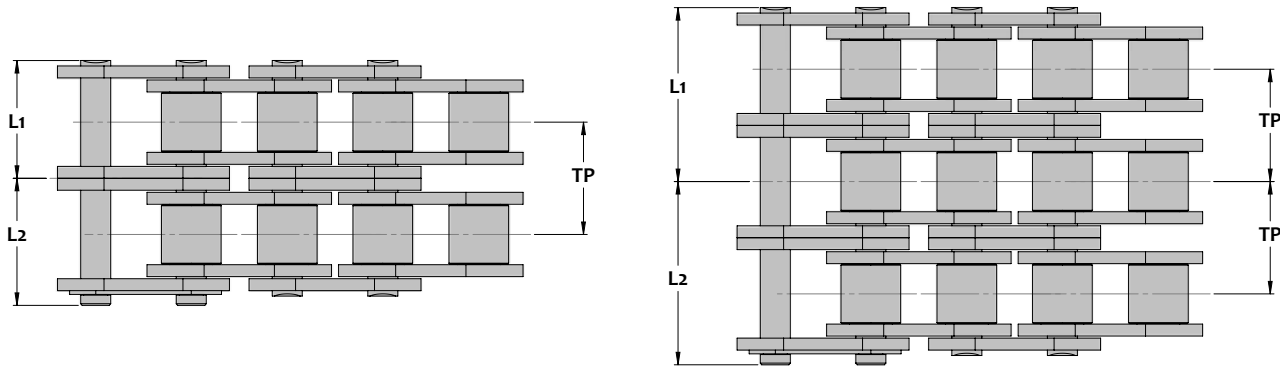
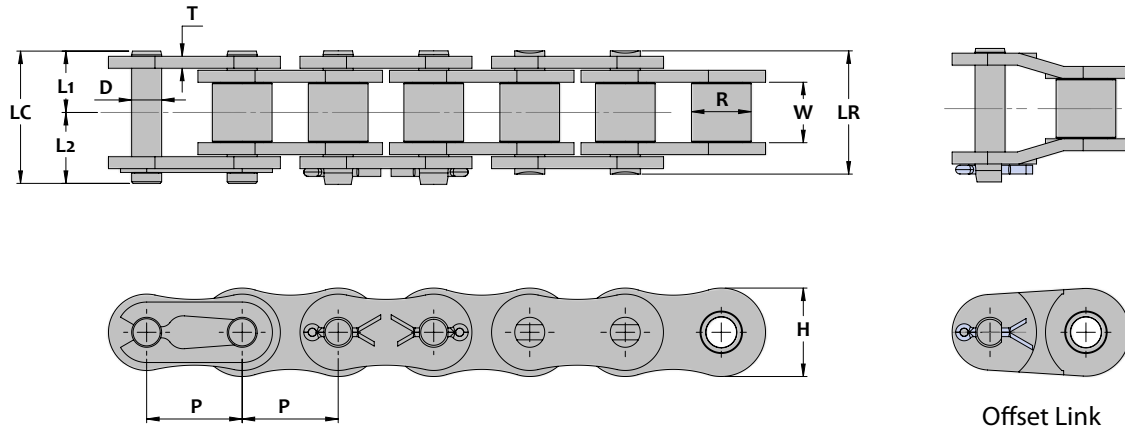

Chain Dimensions

Common Dimensions										
MAXCO Chain Number	Units	Chain Pitch P	Inside Width W	Roller Diameter R	Pin Diameter D	Link Plate Thickness T	Roller Link Plate Height H	Number of Links in 10ft/5m	Available Construction	
									Cottered	Riveted
80	inch mm	1.000 25.40	0.625 15.88	0.625 15.88	0.312 7.93	0.126 3.2	0.921 23.4	120 198	Yes	Yes
Pin Lengths and Chain Ratings										
MAXCO Chain Number	Units	Number of Strands	Pin Length				Transverse Pitch TP	Rated Working Load Lbs Kg-f	Average Ultimate Strength Lbs Kg-f	Average Chain Weight Lbs/ft Kg/m
			L1	L2	LR	LC				
80	inch mm	1	0.65 16.4	0.75 19.1	1.29 32.8	1.40 35.5	- -	4,295 1,950	17,650 8,025	1.69 2.52
80-2	inch mm	2	1.21 30.8	1.33 33.7	2.43 61.6	2.54 64.5	1.154 29.3	5,630 2,560	35,300 16,045	3.42 5.10
80-3	inch mm	3	1.79 45.5	1.91 48.6	3.58 90.9	3.70 94.1	1.154 29.3	8,280 3,765	53,060 24,120	5.15 7.68
80-4	inch mm	4	2.37 60.2	2.49 63.3	4.74 120.4	4.86 123.5	1.154 29.3	10,900 4,955	70,590 32,085	6.87 10.3
80-5	inch mm	5	2.95 74.9	3.07 77.9	5.90 149.8	6.02 152.8	1.154 29.3	12,900 5,865	88,350 40,160	8.60 12.8
80-6	inch mm	6	3.53 89.6	3.64 92.5	7.05 179.1	7.17 182.1	1.154 29.3	15,200 6,910	105,890 48,130	10.3 15.4

100 ASME/ANSI Roller Chain

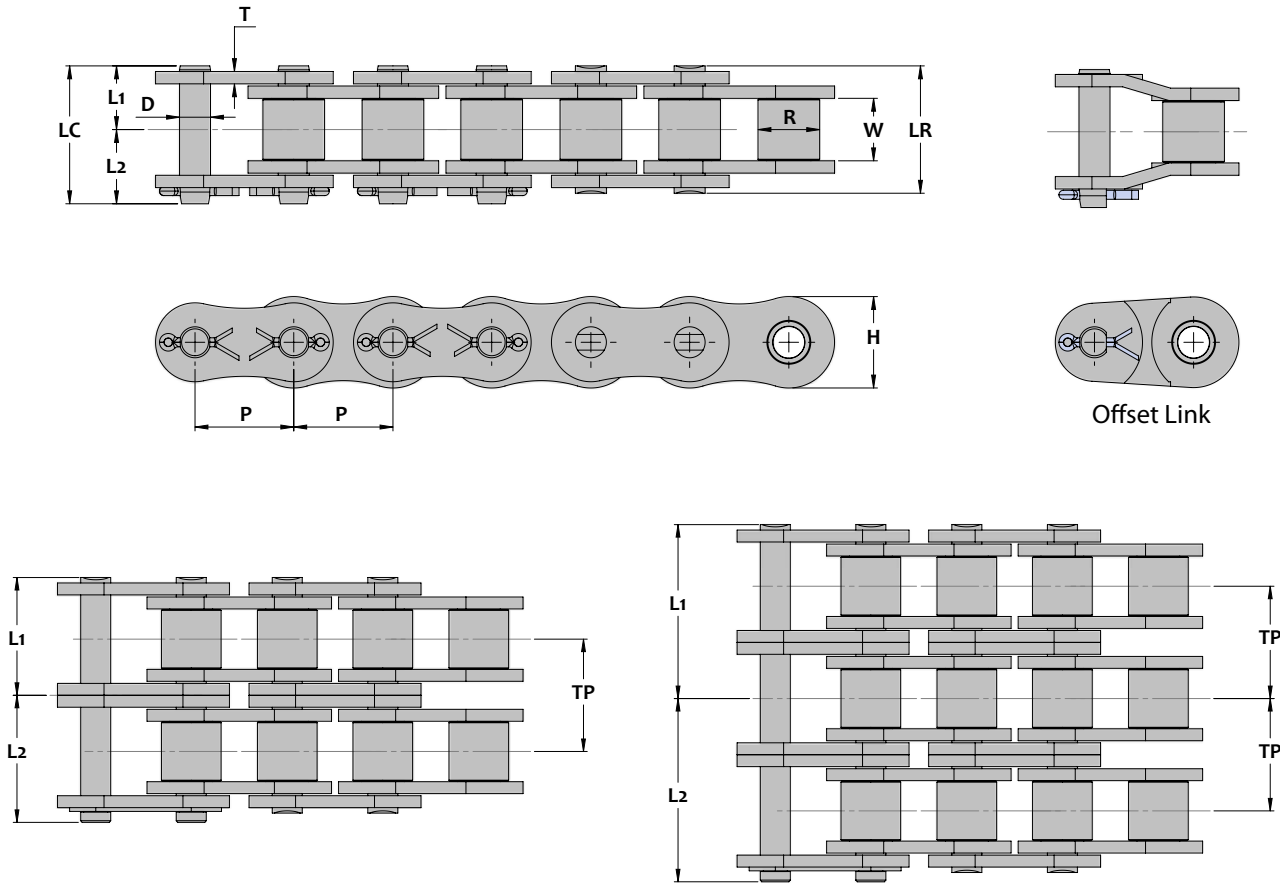

Chain Dimensions

Common Dimensions										
MAXCO Chain Number	Units	Chain Pitch P	Inside Width W	Roller Diameter R	Pin Diameter D	Link Plate Thickness T	Roller Link Plate Height H	Number of Links in 10ft/5m	Available Construction	
									Cottered	Riveted
100	inch	1.250	0.750	0.750	0.375	0.157	1.154	96	Yes	Yes
	mm	31.75	19.05	19.05	9.53	4.0	29.3	158		
Pin Lengths and Chain Ratings										
MAXCO Chain Number	Units	Number of Strands	Pin Length				Transverse Pitch TP	Rated Working Load	Average Ultimate Strength	Average Chain Weight
			L1	L2	LR	LC				
			Lbs	Kg-f	Lbs	Kg-f	Lbs	Kg-f	Lbs/ft	Kg/m
100	inch	1	0.78	0.92	1.55	1.69	-	6,610	26,500	2.62
	mm		19.7	23.3	39.4	43.0	-	3,005	12,045	3.91
100-2	inch	2	1.48	1.62	2.96	3.10	1.409	8,650	53,000	5.19
	mm		37.6	41.2	75.1	78.8	35.8	3,930	24,090	7.74
100-3	inch	3	2.19	2.33	4.37	4.51	1.409	12,730	79,500	7.77
	mm		55.5	59.1	110.9	114.6	35.8	5,785	36,135	11.6
100-4	inch	4	2.90	3.04	5.80	5.94	1.409	16,800	106,000	10.3
	mm		73.7	77.1	147.4	150.8	35.8	7,635	48,180	15.4
100-5	inch	5	3.60	3.74	7.20	7.35	1.409	19,850	132,500	12.9
	mm		91.5	95.1	183.0	186.6	35.8	9,025	60,225	19.3
100-6	inch	6	4.31	4.45	8.61	8.76	1.409	23,400	159,000	15.5
	mm		109.4	113.0	218.8	222.4	35.8	10,635	72,275	23.1

120 ASME/ANSI Roller Chain

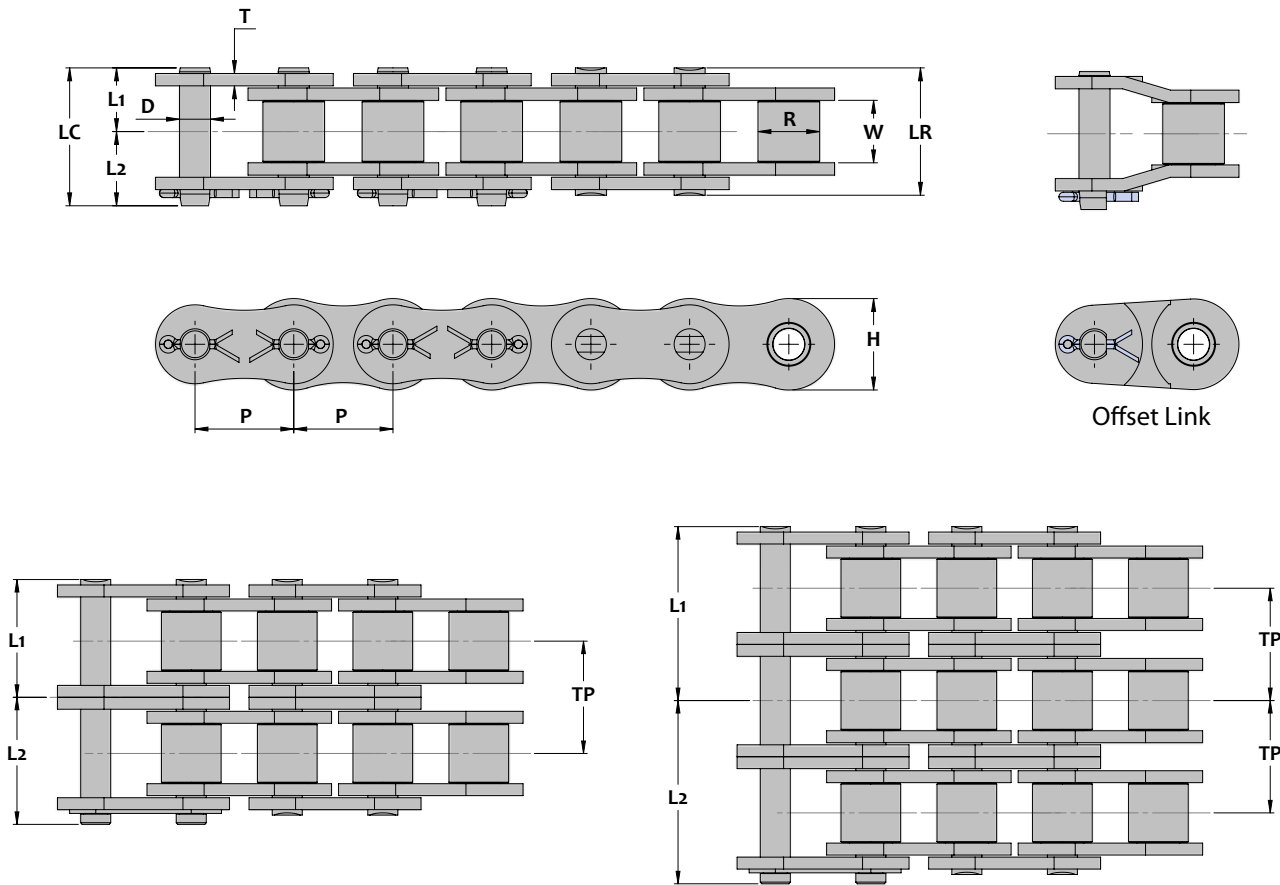

Chain Dimensions

Common Dimensions										
MAXCO Chain Number	Units	Chain Pitch P	Inside Width W	Roller Diameter R	Pin Diameter D	Link Plate Thickness T	Roller Link Plate Height H	Number of Links in 10ft/5m	Available Construction	
120	inch mm	1.500 38.10	1.000 25.40	0.875 22.23	0.437 11.10	0.188 4.8	1.382 35.1	80 132	Cottered	Riveted
Pin Lengths and Chain Ratings										
MAXCO Chain Number	Units	Number of Strands	Pin Length				Transverse Pitch TP	Rated Working Load	Average Ultimate Strength	Average Chain Weight
			L1	L2	LR	LC				
120	inch mm	1	0.98 24.8	1.13 28.6	1.95 49.5	2.10 53.4	- -	8,880 4,035	39,000 17,725	3.86 5.76
120-2	inch mm	2	1.87 47.5	2.02 51.3	3.74 94.9	3.89 98.8	1.787 45.4	11,620 5,280	78,000 35,455	7.70 11.5
120-3	inch mm	3	2.76 70.2	2.91 74.0	5.52 140.3	5.68 144.2	1.787 45.4	17,080 7,765	117,000 53,180	11.5 17.2
120-4	inch mm	4	3.67 93.1	3.81 96.9	7.33 186.1	7.48 190.0	1.787 45.4	22,550 10,250	156,000 70,910	15.4 22.9
120-5	inch mm	5	4.56 115.8	4.71 119.6	9.11 231.5	9.27 235.4	1.787 45.4	26,750 12,160	195,000 88,635	19.2 28.7
120-6	inch mm	6	5.45 138.5	5.60 142.3	10.90 276.9	11.06 280.8	1.787 45.4	31,470 14,305	234,000 106,365	23.0 34.4

140 ASME/ANSI Roller Chain

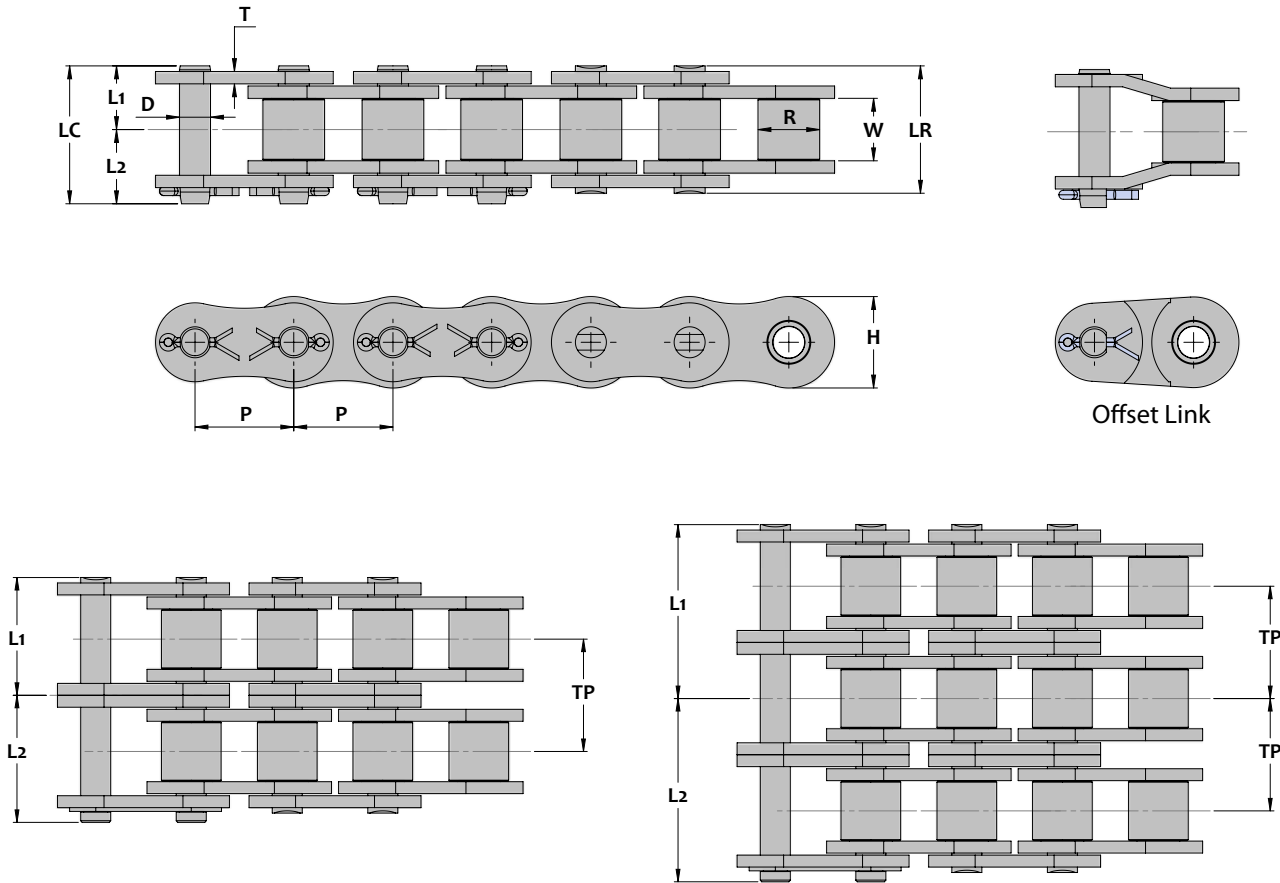

Chain Dimensions

Common Dimensions										
MAXCO Chain Number	Units	Chain Pitch P	Inside Width W	Roller Diameter R	Pin Diameter D	Link Plate Thickness T	Roller Link Plate Height H	Number of Links in 10ft/5m	Available Construction	
									Cottered	Riveted
140	inch	1.750	1.000	1.000	0.500	0.220	1.610	70	Yes	Yes
	mm	44.45	25.40	25.40	12.70	5.6	40.9	116		
Pin Lengths and Chain Ratings										
MAXCO Chain Number	Units	Number of Strands	Pin Length				Transverse Pitch TP	Rated Working Load	Average Ultimate Strength	Average Chain Weight
			L1	L2	LR	LC				
140	inch	1	1.06	1.23	2.13	2.30	-	11,750	48,600	4.97
	mm		27.0	31.3	54.0	58.3	-	5,340	22,090	7.41
140-2	inch	2	2.03	2.19	4.05	4.22	1.925	15,400	97,200	9.81
	mm		51.5	55.7	102.9	107.2	48.9	7,000	44,180	14.6
140-3	inch	3	2.99	3.17	5.97	6.15	1.925	22,700	145,800	14.7
	mm		75.9	80.4	151.7	156.3	48.9	10,320	66,275	21.9
140-4	inch	4	3.96	4.13	7.92	8.09	1.925	29,900	194,400	19.6
	mm		100.6	104.9	201.2	205.5	48.9	13,590	88,365	29.2
140-5	inch	5	4.93	5.09	9.85	10.02	1.925	35,400	243,000	24.4
	mm		125.1	129.3	250.1	254.4	48.9	16,090	110,455	36.5
140-6	inch	6	5.89	6.06	11.77	11.94	1.925	41,580	291,600	29.3
	mm		149.5	153.8	299.0	303.3	48.9	18,900	132,545	43.7

160 ASME/ANSI Roller Chain

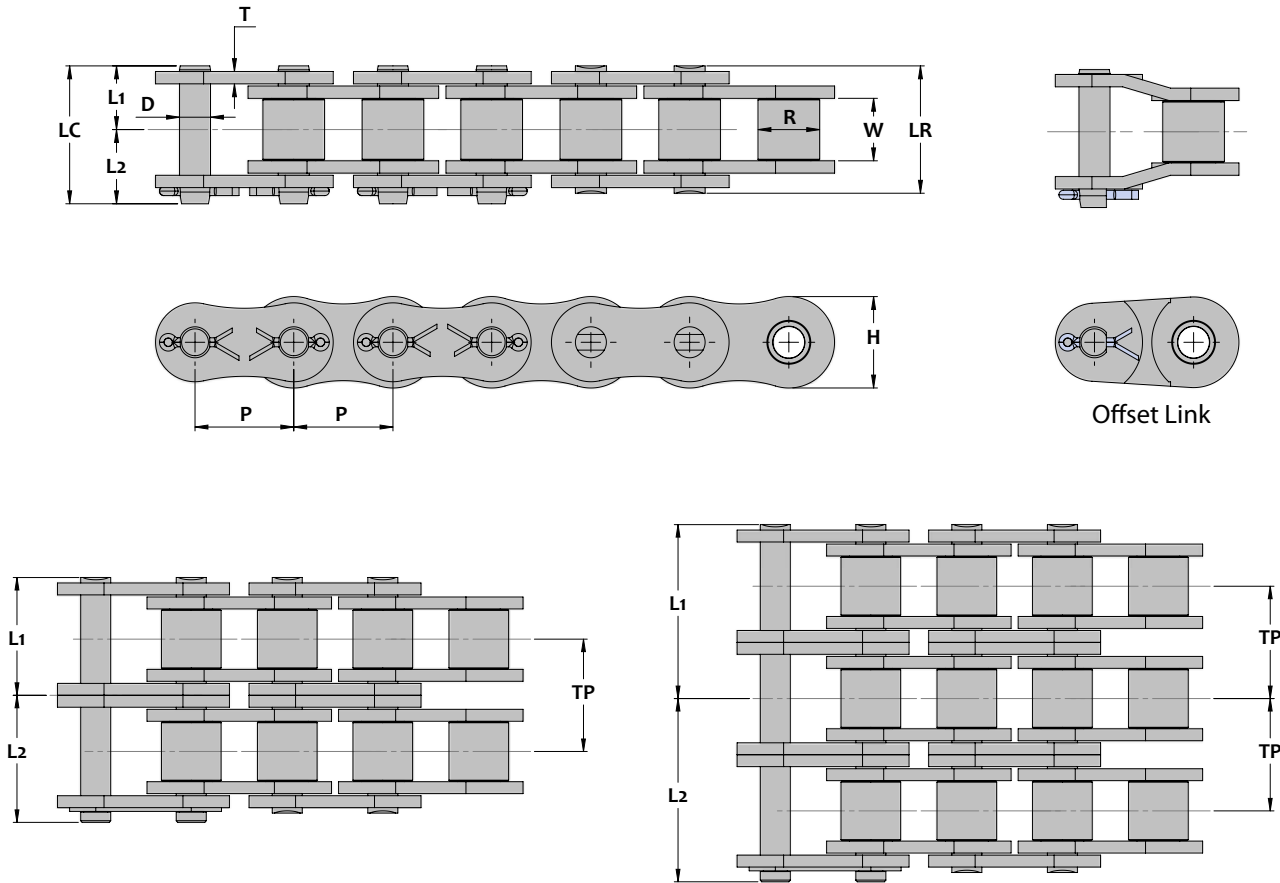

Chain Dimensions

Common Dimensions										
MAXCO Chain Number	Units	Chain Pitch P	Inside Width W	Roller Diameter R	Pin Diameter D	Link Plate Thickness T	Roller Link Plate Height H	Number of Links in 10ft/5m	Available Construction	
									Cottered	Riveted
160	inch	2.000	1.250	1.125	0.562	0.250	1.839	60	Yes	Yes
	mm	50.80	31.75	28.58	14.28	6.4	46.7	98		
Pin Lengths and Chain Ratings										
MAXCO Chain Number	Units	Number of Strands	Pin Length				Transverse Pitch TP	Rated Working Load	Average Ultimate Strength	Average Chain Weight
			L1	L2	LR	LC				
160	inch	1	1.27	1.44	2.53	2.70	-	15,500	63,000	6.56
	mm		32.2	36.5	64.3	68.7	-	7,045	28,635	9.79
160-2	inch	2	2.42	2.59	4.83	5.01	2.303	20,250	126,000	13.0
	mm		61.4	65.8	122.8	127.2	58.50	9,205	57,275	19.5
160-3	inch	3	3.57	3.74	7.14	7.31	2.303	29,900	189,000	19.6
	mm		90.7	95.0	181.3	185.7	58.50	13,590	85,910	29.2
160-4	inch	4	4.73	4.90	9.46	9.63	2.303	39,300	252,000	26.0
	mm		120.2	124.5	240.3	244.7	58.50	17,865	114,545	38.8
160-5	inch	5	5.88	6.06	11.76	11.94	2.303	46,500	315,000	32.5
	mm		149.4	153.9	298.8	303.3	58.50	21,135	143,180	48.4
160-6	inch	6	7.04	7.20	14.07	14.24	2.303	54,800	378,000	38.9
	mm		178.7	183.0	357.4	361.7	58.50	24,910	171,820	58.1

180 ASME/ANSI Roller Chain

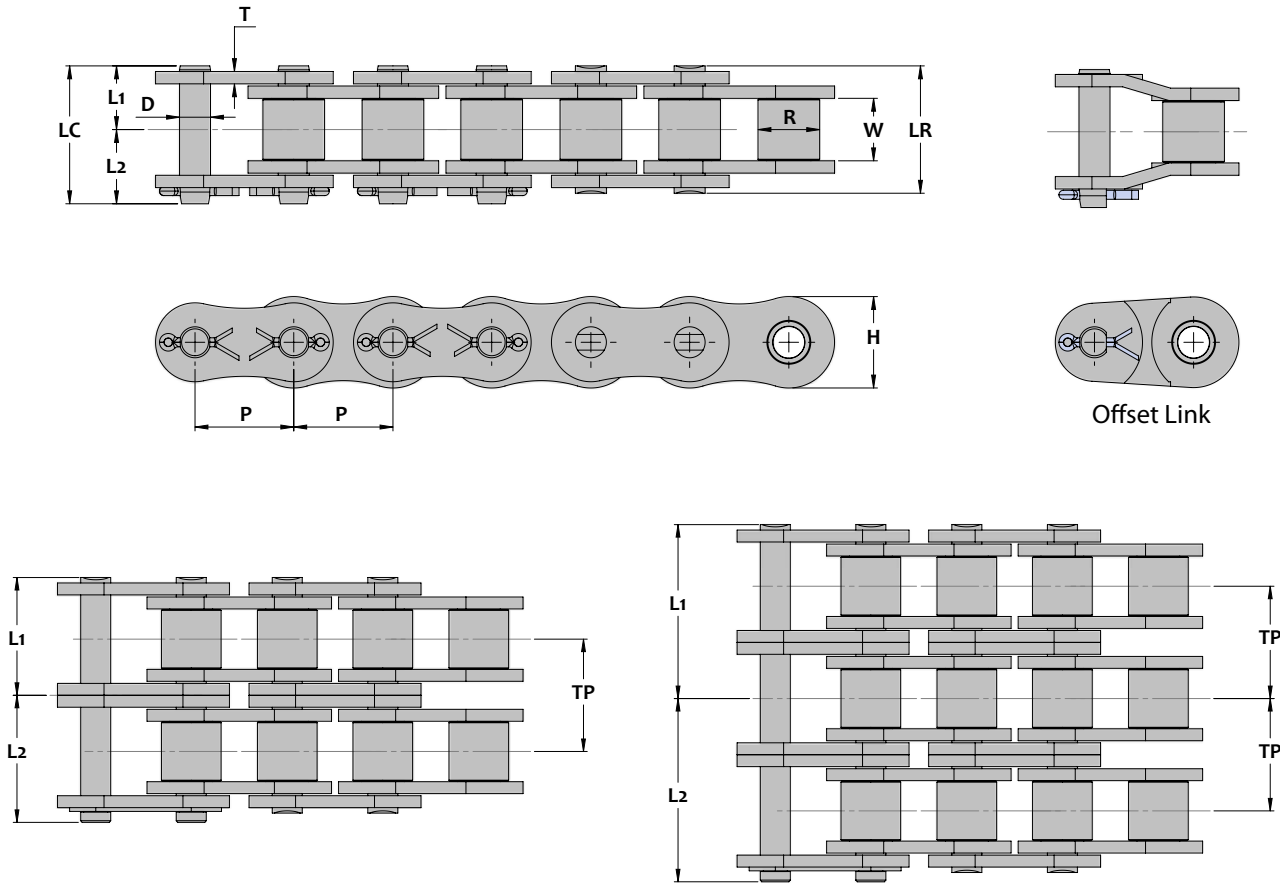

Chain Dimensions

Common Dimensions										
MAXCO Chain Number	Units	Chain Pitch P	Inside Width W	Roller Diameter R	Pin Diameter D	Link Plate Thickness T	Roller Link Plate Height H	Number of Links in 10ft/5m	Available Construction	
180	inch mm	2.250 57.15	1.406 35.70	1.406 35.70	0.687 17.45	0.283 7.2	2.067 52.5	54 90	Cottered Yes	Riveted Yes
Pin Lengths and Chain Ratings										
MAXCO Chain Number	Units	Number of Strands	Pin Length				Transverse Pitch TP	Rated Working Load	Average Ultimate Strength	Average Chain Weight
			L1	L2	LR	LC				
180	inch mm	1	1.43 36.3	1.66 42.1	2.85 72.5	3.09 78.4	- -	17,750 8,070	81,500 37,045	8.98 13.4
180-2	inch mm	2	2.72 69.1	2.95 74.9	5.44 138.2	5.67 144.0	2.591 65.8	23,300 10,590	163,000 74,090	17.9 26.6
180-3	inch mm	3	4.03 102.3	4.25 107.9	8.05 204.5	8.28 210.2	2.591 65.8	34,400 15,590	244,500 111,135	26.7 39.9
180-4	inch mm	4	5.32 135.1	5.54 140.8	10.64 270.2	10.86 275.9	2.591 65.8	45,200 20,545	326,000 148,180	35.6 53.1
180-5	inch mm	5	6.83 173.6	6.84 173.7	13.23 336.0	13.45 341.6	2.591 65.8	53,310 24,230	407,500 185,225	44.5 66.3
180-6	inch mm	6	7.91 200.9	8.13 206.4	15.82 401.8	16.04 407.3	2.591 65.8	62,900 28,590	489,000 222,275	53.3 79.5

200 ASME/ANSI Roller Chain

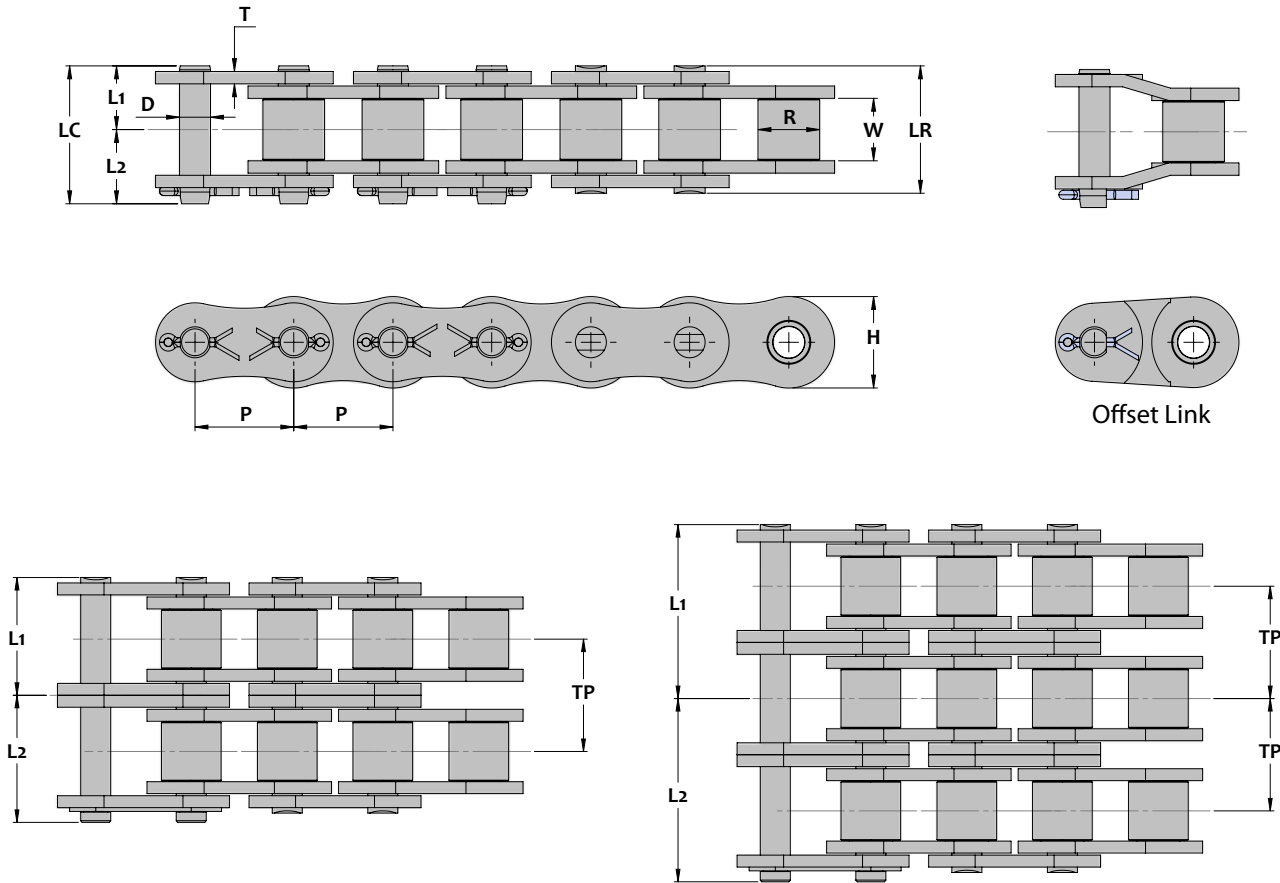

Chain Dimensions

Common Dimensions										
MAXCO Chain Number	Units	Chain Pitch P	Inside Width W	Roller Diameter R	Pin Diameter D	Link Plate Thickness T	Roller Link Plate Height H	Number of Links in 10ft/5m	Available Construction	
200	inch	2.500	1.500	1.562	0.781	0.315	2.354	48	Yes	Yes
	mm	63.50	38.10	39.67	19.83	8.0	59.8	80		
Pin Lengths and Chain Ratings										
MAXCO Chain Number	Units	Number of Strands	Pin Length				Transverse Pitch TP	Rated Working Load	Average Ultimate Strength	Average Chain Weight
			L1	L2	LR	LC				
200	inch	1	1.55	1.88	3.09	3.43	-	20,900	105,000	11.4
	mm		39.3	47.7	78.5	87.0	-	9,500	47,725	16.9
200-2	inch	2	2.96	3.29	5.91	6.25	2.819	27,430	210,000	22.6
	mm		75.1	83.6	150.2	158.7	71.6	12,470	95,455	33.7
200-3	inch	3	4.37	4.70	8.73	9.06	2.819	40,240	315,000	33.9
	mm		110.9	119.3	221.7	230.2	71.6	18,290	143,180	50.5
200-4	inch	4	5.78	6.13	11.55	11.91	2.819	53,100	420,000	45.2
	mm		146.7	155.7	293.3	302.4	71.6	24,135	190,910	67.3
200-5	inch	5	7.20	7.53	14.39	14.72	2.819	62,750	525,000	56.4
	mm		182.8	191.2	365.5	374.0	71.6	28,525	238,635	84.1
200-6	inch	6	8.61	8.94	17.21	17.54	2.819	74,000	630,000	67.7
	mm		218.6	227.0	437.1	445.6	71.6	15,000	286,365	100.9

200 ASME/ANSI Roller Chain

Horsepower Capacity Table

# Teeth Small Sprocket	Maximum Speed of Small Sprocket (rpm)																			
	10	15	20	30	40	50	70	100	150	200	250	300	350	400	450	500	550	600	650	
9	6.53	9.40	12.17	17.53	22.71	27.76	37.59	51.81	74.62	96.69	118.2	139.3	145.8	119.4	100.1	85.46	74.06	65.00	57.65	
10	7.31	10.52	13.63	19.65	25.46	31.11	42.12	58.06	83.62	108.3	132.4	156.0	170.9	139.8	117.2	100.1	86.74	76.14	67.52	
11	8.10	11.68	15.12	21.77	28.20	34.49	46.68	64.36	92.69	120.1	146.8	172.9	197.2	161.4	135.3	115.5	100.1	87.83	77.90	
12	8.90	12.82	16.61	23.91	30.99	37.88	51.29	70.70	101.8	131.9	161.3	189.9	218.2	183.9	154.0	131.6	114.0	100.1		
13	9.71	13.98	18.11	26.09	33.79	41.30	55.91	77.08	111.0	143.8	175.9	207.1	237.9	207.4	173.7	148.4	128.6	112.8		
14	10.51	15.15	19.61	28.26	36.61	44.75	60.56	83.50	120.3	155.8	190.5	224.4	257.8	231.6	194.1	165.8	143.7	126.1		
15	11.33	16.31	21.13	30.44	39.44	48.20	65.25	89.96	129.6	167.8	205.2	241.8	277.7	257.0	215.3	183.9	159.4	139.8		
16	12.14	17.49	22.65	32.64	42.28	51.69	69.96	96.45	138.9	180.0	220.0	259.2	297.9	283.1	237.3	202.5	175.6	154.0		
17	12.96	18.67	24.20	34.84	45.15	55.19	74.71	103.0	148.3	192.2	234.9	276.8	318.0	310.1	259.8	221.8	192.2	168.8		
18	13.79	19.87	25.74	37.06	48.02	58.70	79.45	109.5	157.8	204.4	249.9	294.4	338.2	337.8	283.1	241.7	209.5	183.9		
19	14.62	21.06	27.28	39.29	50.90	62.23	84.24	116.1	167.3	216.6	264.9	312.1	358.6	366.4	307.0	262.1	227.2	199.3		
20	15.46	22.25	28.83	41.53	53.81	65.78	89.03	122.7	176.8	229.1	280.0	329.9	379.0	395.6	331.5	283.1	245.3			
21	16.29	23.46	30.39	43.78	56.72	69.33	93.85	129.4	186.3	241.4	295.2	347.7	399.5	425.6	356.7	304.6	263.9			
22	17.13	24.66	31.96	46.03	59.64	72.90	98.69	136.0	196.0	253.9	310.3	365.7	420.1	456.4	382.4	326.5	283.1			
23	17.96	25.88	33.53	48.30	62.57	76.49	103.5	142.7	205.6	266.4	325.6	383.6	440.8	487.8	408.8	349.1	342.8			
24	18.82	27.10	35.11	50.56	65.51	80.08	108.4	149.4	215.3	278.8	340.9	401.7	461.5	520.0	435.8	372.1	322.5			
25	19.66	28.32	36.69	52.84	68.47	83.70	113.3	156.2	224.9	291.4	356.3	419.8	482.3	543.8	463.3	395.6	342.9			
26	20.51	29.54	38.28	55.13	71.43	87.32	118.2	163.0	234.7	304.0	371.7	437.9	503.1	567.4	491.4	419.6	363.7			
Lube	Type A			Type B							Type C									

Kilowatt Capacity Table

# Teeth Small Sprocket	Maximum Speed of Small Sprocket (rpm)																			
	10	15	20	30	40	50	70	100	150	200	250	300	350	400	450	500	550	600	650	
9	4.87	7.01	9.08	13.08	16.94	20.71	28.04	38.65	55.67	72.13	88.17	103.9	108.8	89.09	74.66	63.75	55.25	48.49	43.01	
10	5.45	7.85	10.17	14.66	18.99	23.21	31.42	43.31	62.38	80.82	98.79	116.4	127.5	104.3	87.44	74.66	64.71	56.80	50.37	
11	6.04	8.71	11.28	16.24	21.04	25.73	34.82	48.01	69.15	89.58	109.5	129.0	147.1	120.4	100.9	86.13	74.66	65.52	58.11	
12	6.64	9.56	12.39	17.84	23.12	28.26	38.26	52.74	75.96	98.41	120.3	141.7	162.8	137.2	114.9	98.14	85.07	74.66		
13	7.24	10.43	13.51	19.46	25.21	30.81	41.71	57.50	82.82	107.3	131.2	154.5	177.5	154.7	129.6	110.7	95.92	84.18		
14	7.84	11.30	14.63	21.08	27.31	33.38	45.18	62.29	89.72	116.2	142.1	167.4	192.3	172.8	144.8	123.7	107.2	94.08		
15	8.45	12.17	15.76	22.71	29.42	35.96	48.68	67.11	96.66	125.2	153.1	180.4	207.2	191.7	160.6	137.2	118.9	104.3		
16	9.06	13.05	16.90	24.35	31.54	38.56	52.19	71.95	103.6	134.3	164.1	193.4	222.2	211.2	177.0	151.1	131.0	114.9		
17	9.67	13.93	18.05	25.99	33.68	41.17	55.73	76.82	110.7	143.4	175.2	206.5	237.2	231.3	193.8	165.5	143.4	125.9		
18	10.29	14.82	19.20	27.65	35.82	43.79	59.27	81.71	117.7	152.5	186.4	219.6	252.3	252.0	211.2	180.3	156.3	137.2		
19	10.91	15.71	20.35	29.31	37.97	46.42	62.84	86.62	124.8	161.6	197.6	232.8	267.5	273.3	229.0	195.5	169.5	148.7		
20	11.53	16.60	21.51	30.98	40.14	49.07	66.42	91.56	131.9	170.9	208.9	246.1	282.7	295.1	247.3	211.2	183.0			
21	12.15	17.50	22.67	32.66	42.31	51.72	70.01	96.51	139.0	180.1	220.2	259.4	298.0	317.5	266.1	227.2	196.9			
22	12.78	18.40	23.84	34.34	44.49	54.38	73.62	101.5	146.2	189.4	231.5	272.8	313.4	340.5	285.3	243.6	211.2			
23	13.40	19.31	25.01	36.03	46.68	57.06	77.24	106.5	153.4	198.7	242.9	286.2	328.8	363.9	305.0	260.4	255.7			
24	14.04	20.22	26.19	37.72	48.87	59.74	80.87	111.5	160.6	208.0	254.3	299.7	344.3	387.9	325.1	277.6	240.6			
25	14.67	21.13	27.37	39.42	51.08	62.44	84.52	116.5	167.8	217.4	265.8	313.2	359.8	405.7	345.6	295.1	255.8			
26	15.30	22.04	28.56	41.13	53.29	65.14	88.18	121.6	175.1	226.8	277.3	326.7	375.3	423.3	366.6	313.0	271.3			
Lube	Type A			Type B							Type C									

Lube Type A: Manual or Drip Lubrication
Lube Type B: Bath or Slinger Disc Lubrication
Lube Type C: Oil Stream or Pressure Spray Lubrication

Note: Power ratings in above tables are for single strand chains only. For multiple strand chains multiply the table value by the multi-strand factor shown in the table to the right.

Number of Strands	2	3	4	5	6
Multi-Strand Factor	1.7	2.5	3.3	3.9	4.6

240 ASME/ANSI Roller Chain

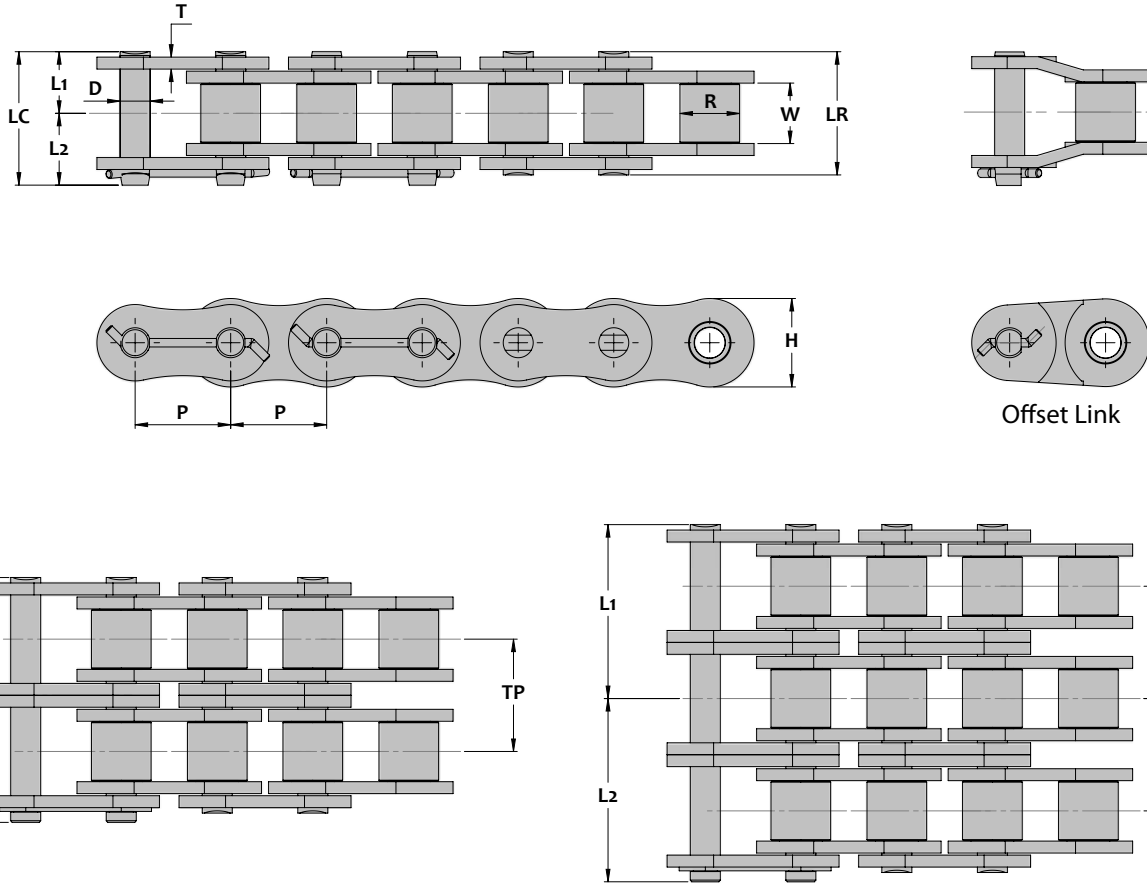

Chain Dimensions

Common Dimensions										
MAXCO Chain Number	Units	Chain Pitch P	Inside Width W	Roller Diameter R	Pin Diameter D	Link Plate Thickness T	Roller Link Plate Height H	Number of Links in 10ft/5m	Available Construction	
240	inch mm	3.000 76.20	1.875 47.63	1.875 47.63	0.936 23.78	0.374 9.5	2.768 70.3	40 66	Yes	Yes
Pin Lengths and Chain Ratings										
MAXCO Chain Number	Units	Number of Strands	Pin Length				Transverse Pitch TP	Rated Working Load Lbs Kg-f	Average Ultimate Strength Lbs Kg-f	Average Chain Weight Lbs/ft Kg/m
			L1	L2	LR	LC				
240	inch mm	1	1.90 48.2	2.20 55.9	3.80 96.4	4.10 104.1	- -	29,000 13,180	152,200 69,180	15.9 23.6
240-2	inch mm	2	3.63 92.1	3.93 99.7	7.25 184.2	7.55 191.8	3.457 87.8	37,900 17,225	304,400 138,365	31.6 47.1
240-3	inch mm	3	5.35 136.0	5.65 143.6	10.71 272.0	11.01 279.6	3.457 87.8	55,700 25,320	456,600 207,545	47.3 70.6
240-4	inch mm	4	7.08 179.9	7.38 187.5	14.17 359.8	14.46 367.4	3.457 87.8	72,840 33,110	608,800 276,725	63.1 94.1
240-5	inch mm	5	8.81 223.8	9.11 23.14	17.62 447.6	17.92 455.2	3.457 87.8	86,900 39,500	761,000 345,910	78.8 117.6
240-6	inch mm	6	10.54 267.8	10.83 275.2	21.09 535.6	21.38 543.0	3.457 87.8	102,500 46,590	913,200 415,090	94.6 141.1



240 ASME/ANSI Roller Chain

Horsepower Capacity Table

# Teeth Small Sprocket	Maximum Speed of Small Sprocket (rpm)																			
	5	10	15	20	25	30	40	50	60	80	100	125	150	175	200	250	300	350	400	450
9	5.63	10.51	15.13	19.60	23.97	28.24	36.58	44.72	52.69	68.27	83.45	102.0	120.2	138.1	155.8	190.3	212.7	168.8	138.2	115.8
10	6.31	11.77	16.96	21.97	26.85	31.64	40.99	50.11	59.05	76.49	93.50	114.3	134.7	154.7	174.5	213.3	249.2	197.7	161.8	135.7
11	7.00	13.04	18.79	24.34	29.76	35.07	45.43	55.54	65.44	84.72	103.6	126.7	149.3	171.4	193.4	236.5	278.6	228.2	186.7	156.4
12	7.68	14.33	20.64	26.74	32.69	38.53	49.91	61.02	71.89	93.14	113.9	139.2	163.9	188.3	212.5	259.7	306.0	259.9	212.7	
13	8.38	15.63	22.51	29.17	35.64	42.01	54.42	66.53	78.38	101.6	124.1	151.7	178.8	205.4	231.6	283.1	333.6	293.0	239.8	
14	9.08	16.93	24.38	31.60	38.62	45.51	58.95	72.06	84.92	110.0	134.5	164.3	193.7	222.5	250.9	306.7	361.5	327.5	268.1	
15	9.77	18.24	26.27	34.03	41.61	49.02	63.51	77.64	91.49	118.5	144.9	177.1	208.7	239.7	270.4	330.4	389.4	363.3	297.3	
16	10.48	19.56	28.16	36.49	44.61	52.56	68.10	83.24	98.08	127.1	155.4	189.9	223.7	257.1	289.8	354.3	417.6	400.1	327.5	
17	11.19	20.88	30.08	38.97	47.63	56.13	72.71	88.87	104.7	135.7	165.8	202.7	238.9	274.4	309.5	378.3	445.8	438.2	358.7	
18	11.90	22.21	31.98	41.45	50.66	59.69	77.33	94.53	111.4	144.3	176.4	215.7	254.2	292.0	329.2	402.4	474.1	477.5	390.8	
19	12.61	23.54	33.91	43.94	53.71	63.28	81.98	100.2	118.1	153.0	187.0	228.6	269.4	309.5	348.9	426.7	502.7	517.8	423.9	
20	13.34	24.88	35.84	46.43	56.77	66.89	86.66	105.9	124.8	161.7	197.7	241.7	284.7	327.1	368.9	450.9	531.4	559.2	457.8	
21	14.06	26.23	37.79	48.95	59.84	70.51	91.34	111.7	131.6	170.5	208.3	254.7	300.1	344.8	388.9	475.3	560.1	601.7	492.5	
22	14.79	27.59	39.73	51.47	62.92	74.14	96.05	117.4	138.4	179.2	219.2	267.8	315.5	362.6	408.8	499.9	588.9	645.2	528.0	
23	15.51	28.94	41.69	54.01	66.02	77.79	100.8	123.2	145.2	188.1	229.9	281.0	331.1	380.4	429.0	524.4	617.8	689.7	564.5	
24	16.23	30.29	43.65	56.54	69.12	81.45	105.5	129.0	152.0	196.9	240.8	294.2	346.6	398.3	449.2	549.1				
25	16.97	31.66	45.62	59.09	72.24	85.12	110.3	134.8	158.8	205.8	251.6	307.5	362.3	416.2	469.4	573.9				
26	17.71	33.04	47.59	61.65	75.36	88.81	115.0	140.6	165.7	214.7	262.5	320.8	378.0	434.3	489.7	598.7				
Lube	Type A					Type B										Type C				

Kilowatt Capacity Table

# Teeth Small Sprocket	Maximum Speed of Small Sprocket (rpm)																			
	5	10	15	20	25	30	40	50	60	80	100	125	150	175	200	250	300	350	400	450
9	4.20	7.84	11.29	14.62	17.88	21.07	27.29	33.36	39.31	50.93	62.25	76.10	89.67	103.0	116.2	142.0	158.7	125.9	103.1	86.38
10	4.71	8.78	12.65	16.39	20.03	23.60	30.58	37.38	44.05	57.06	69.75	85.27	100.5	115.4	130.2	159.1	185.9	147.5	120.7	101.2
11	5.22	9.73	14.02	18.16	22.20	26.16	33.89	41.43	48.82	63.20	77.32	94.51	111.4	127.9	144.3	176.4	207.8	170.2	139.3	116.7
12	5.73	10.69	15.40	19.95	24.39	28.74	37.23	45.52	53.63	69.48	84.94	103.8	122.3	140.5	158.5	193.7	228.3	193.9	158.7	
13	6.25	11.66	16.79	21.76	26.59	31.34	40.60	49.63	58.47	75.76	92.60	113.2	133.4	153.2	172.8	211.2	248.9	218.6	178.9	
14	6.77	12.63	18.19	23.57	28.81	33.95	43.98	53.76	63.35	82.07	100.3	122.6	144.5	166.0	187.2	228.8	269.7	244.3	200.0	
15	7.29	13.61	19.60	25.39	31.04	36.57	47.38	57.92	68.25	88.42	108.1	132.1	155.7	178.8	201.7	246.5	290.5	271.0	221.8	
16	7.82	14.59	21.01	27.22	33.28	39.21	50.80	62.10	73.17	94.80	115.9	141.7	166.9	191.8	216.2	264.3	311.5	298.5	244.3	
17	8.35	15.58	22.44	29.07	35.53	41.87	54.24	66.30	78.13	101.2	123.7	151.2	178.2	204.7	230.9	282.2	332.6	326.9	267.6	
18	8.88	16.57	23.86	30.92	37.79	44.53	57.69	70.52	83.10	107.7	131.6	160.9	189.6	217.8	245.6	300.2	353.7	356.2	291.5	
19	9.41	17.56	25.30	32.78	40.07	47.21	61.16	74.77	88.10	114.1	139.5	170.5	201.0	230.9	260.3	318.3	375.0	386.3	316.2	
20	9.95	18.56	26.74	34.64	42.35	49.90	64.65	79.02	93.12	120.6	147.5	180.3	212.4	244.0	275.2	336.4	396.4	417.2	341.5	
21	10.49	19.57	28.19	36.52	44.64	52.60	68.14	83.30	98.15	127.2	155.4	190.0	223.9	257.2	290.1	354.6	417.8	448.9	367.4	
22	11.03	20.58	29.64	38.40	46.94	55.31	71.65	87.59	103.2	133.7	163.5	199.8	235.4	270.5	305.0	372.9	439.3	481.3	393.9	
23	11.57	21.59	31.10	40.29	49.25	58.03	75.18	91.90	108.3	140.3	171.5	209.6	247.0	283.8	320.0	391.2	460.9	514.5	421.1	
24	12.11	22.60	32.56	42.18	51.56	60.76	78.71	96.22	113.4	146.9	179.6	219.5	258.6	297.1	335.1	409.6				
25	12.66	23.62	34.03	44.08	53.89	63.50	82.26	100.6	118.5	153.5	187.7	229.4	270.3	310.5	350.2	428.1				
26	13.21	24.65	35.50	45.99	56.22	66.25	85.82	104.9	123.6	160.2	195.8	239.3	282.0	324.0	365.3	446.6				
Lube	Type A					Type B										Type C				

Lube Type A: Manual or Drip Lubrication
 Lube Type B: Bath or Slinger Disc Lubrication
 Lube Type C: Oil Stream or Pressure Spray Lubrication

Note: Power ratings in above tables are for single strand chains only. For multiple strand chains multiply the table value by the multi-strand factor shown in the table to the right.

Number of Strands	2	3	4	5	6
Multi-Strand Factor	1.7	2.5	3.3	3.9	4.6

ASME/ANSI Drive Chain Selection

Introduction

Roller chains are one of the most efficient and cost effective ways to transmit mechanical power between shafts. They operate over a wide range of speeds, handle large working loads, have very small energy losses and are generally inexpensive compared with other methods of transmitting power. Successful selection involves following several relatively simple steps involving algebraic calculation and the use of horsepower and service factor tables.

For any given set of drive conditions, there are a number of possible chain/sprocket configurations that can successfully operate. The designer therefore should be aware of several basic selection principles that when applied correctly, help balance overall drive performance and cost. By following the steps outlined in this section designers should be able to make selections that meet the requirements of the drive and are cost effective.

General Roller Chain Drive Principles

- The recommended number of teeth for the small sprocket is 15. The minimum is 9 teeth - smoother operation is obtained with more teeth.
- The recommended maximum number of teeth for the large sprocket is 120. Note that while more teeth allows for smoother operation having too many teeth leads to chain jumping off the sprocket after a relatively small amount of chain elongation due to wear - That is chains with a very large number of teeth accommodate less wear before the chain will no longer wrap around them properly.
- Speed ratios should be 7:1 or less (optimum) and not greater than 10:1. For larger ratios the use of multiple chain reductions is suggested.
- The recommended minimum wrap of the small sprocket is 120°.
- The recommended center distance between shafts is 30-50 pitches of chain. There are two exceptions to this as follows:

1. The center distance must be greater than the sum of the outside diameters of the driver and driven sprockets to prevent interference.
2. For speed ratios greater than 3:1 the center distance should not be less than the outside diameter of the large sprocket minus the outside diameter of the small sprocket to assure a minimum 120° wrap around the small sprocket.

Required Information For Drive Chain Selection

- Type of input power (electric motor, internal combustion engine with mechanical or hydraulic drive).
- Type of equipment to be driven.
- Amount of horsepower required to provide sufficient power to the driven shaft.
- Full load speed of the fastest running shaft (rpm).
- Desired speed of the slow running shaft (or the required speed ratio).
NOTE: *If speeds are variable determine the horsepower to be transmitted at each speed.*
- Diameters of the drive and driven shafts . . . This value may restrict the minimum number of teeth for the sprockets.
- Center distance of the shafts.
- Note the position and any space limitations that may exist. Usually these limitations are on the maximum diameter of sprockets (this restricts the use of single strand chains) or the width of the chain (this restricts the use of multi-strand chains).
- Conditions of the drive including a determination of the class of load (uniform, moderate or heavy), severe operating temperatures or chemically aggressive environments should be noted.

Abbreviations Used In Equations

- N** Number of teeth on the large sprocket.
- n** Number of teeth on the small sprocket.
- R** Speed in revolutions per minute (rpm) of the large sprocket.
- r** Speed in revolutions per minute (rpm) of the small sprocket.
- C** Shaft center distance in chain pitches.
- HP** Horsepower rating of the drive motor or engine.
- KW** Kilowatt power rating of drive motor or engine if using metric units.
- SF** Service Factor (see Table 1).

The Drive Chain Selection Procedure

The following steps should be used to select chain and sprocket sizes, determine the minimum center distance, and calculate the length of chain needed in pitches. We will primarily use Imperial units (such as horsepower) in this section however Kilowatt Capacity tables are available for each chain size in the preceding section. The selection method is the same regardless of the units used.

Step 1: Determine the Class of the Driven Load

Estimate which of the following best characterizes the condition of the drive.

- Uniform: Smooth operation. Little or no shock loading. Soft start up.
- Moderate: Normal or moderate shock loading.
- Heavy: Severe shock loading. Frequent starts and stops.

Step 2: Determine the Service Factor

From Table 1 below determine the appropriate Service Factor (SF) for the drive.

Table 1: Service Factors

Class of Driven Load	Type of Input Power		
	Internal Combustion Engine with Hydraulic Drive	Electric Motor or Turbine	Internal Combustion Engine with Mechanical Drive
Uniform	1.0	1.0	1.2
Moderate	1.2	1.3	1.4
Heavy	1.4	1.5	1.7

Step 3: Calculate Design Power Requirement

$$\text{Design Horsepower (DHP)} = \text{HP} \times \text{SF (Imperial Units)}$$

or

$$\text{Design Kilowatt Power (DKW)} = \text{KW} \times \text{SF (Metric Units)}$$

The Design Power Requirement is equal to the motor (or engine) output power times the Service Factor obtained from Table 1.

Step 4: Make a Tentative Chain Selection

From the Quick Selector Chart found on page 42 make a tentative selection of the required chain size in the following manner:

1. If using Kilowatt power - first convert to horsepower for this step by multiplying the motor Kilowatt rating by 1.340 . . . This is necessary since the quick selector chart is shown in horsepower.
2. Locate the Design Horsepower calculated in step 3 by reading up the single, double, triple or quad chain columns. Draw a horizontal line through this value.
3. Locate the rpm of the small sprocket on the horizontal axis of the chart. Draw a vertical line through this value.
4. The intersection of the two lines should indicate the tentative chain selection.

ASME/ANSI Drive Chain Selection

Step 5: Select the Number of Teeth for the Small Sprocket

Once a tentative selection of the chain size is made we need to determine the minimum number of teeth required on the small sprocket required to transmit the Design Horsepower (DHP) or the Design Kilowatt Power (DKW). To do this we consult the Power Capacity tables corresponding to the tentative chain size selected in step 4 (we can also check chains that are one size smaller). Note that both Horsepower Capacity and Kilowatt Capacity tables for each chain size can be found in the preceding pages.

The power values shown in the Capacity Tables are for single strand chains. The values for multiple strand chains may be found by multiplying these values by the appropriate multi-strand factor shown in table 2 below

Table 2: Multi-strand Factors

Number of Strands	2	3	4	5	6
Multi-Strand Factor	1.7	2.5	3.3	3.9	4.6

In the case of multi-strand chains it is easier to calculate a new value for the Design Power Requirement rather than multiplying all of the power capacity values found in the capacity tables by the multi-strand factors. Therefore in order to use the values that are in the tables as they are we take the original calculated DHP or DKW values and divide them by the multi strand factors (the factor for single strand chain is of course 1):

$$\begin{aligned} \text{New Design Horsepower (NDHP)} &= \text{DHP} / \text{Multi-strand Factor} \\ \text{or} \\ \text{New Design Kilowatt Power (NDKW)} &= \text{DKW} / \text{Multi-strand Factor} \end{aligned}$$

The number of teeth on the small sprocket is then determined by:

1. Locating the rpm of the small sprocket along the top row of the power capacity tables.
2. Read down this column until the first value is reached that exceeds the New design Power requirement calculated above.
3. Read across to the first column on the left (# Teeth Small Sprocket) - This value is the minimum number of teeth required on the small sprocket to transmit the power effectively.

Note the lubrication method specified in the Power Capacity tables (Type A, Type B or Type C) - This lubrication method should be used in order to achieve good service life. Additional information regarding lubrication can be found in the Engineering Information sections in the back of this catalog.

Step 6: Determine the Number of Teeth for the Large Sprocket

Use the following to calculate the number of teeth for the large sprocket:

$$N = (r / R) \times n$$

The number of teeth on the large sprocket equals the rpm of the small sprocket (r) divided by the desired rpm of the large sprocket (R) times the number of teeth on the small sprocket. If the sprocket is too large for the space available then multiple strand chains of a smaller pitch should be checked.

Step 7: Determine the Minimum Shaft Center Distance

Use the following to calculate the minimum shaft center distance (in chain pitches):

$$C (\text{min}) = (2N + n) / 6$$

The above is a guide only. Final selection should be determined after consideration of the information given in the "General Roller Chain Drive Principles" at the beginning of this section.

Step 8: Check the Final Selection

Use the information given in the "General Roller Chain Drive Principles" at the beginning of this section to check the selection details. In addition be aware of any potential interference or other space limitations that may exist and adjust the selection accordingly. In general the most efficient/cost effective drive uses single strand chains. This is because multiple strand sprockets are more expensive and as can be ascertained by the multi-strand factors the chains become less efficient in transmitting power as the number of strands increases. It is therefore generally best to specify single strand chains whenever possible

Step 9: Determine the Length of Chain in Pitches

Use the following to calculate the length of the chain (L) in pitches:

$$L = ((N + n) / 2) + (2C) + (K / C)$$

Values for "K" may be found in Table 4 on page 43. Remember that C is the shaft center distance given in pitches of chain (not inches or millimeters etc). If the shaft center distance is known in a unit of length the value C is obtained by dividing the chain pitch (in the same unit) by the shaft centers.

$$\begin{aligned} C &= \text{Shaft Centers (inches)} / \text{Chain Pitch (inches)} \\ &\text{or} \\ C &= \text{Shaft Centers (millimeters)} / \text{Chain Pitch (millimeters)} \end{aligned}$$

Note that whenever possible it is best to utilize an even number of pitches in order to avoid the use of an offset link. Offsets do not possess the same load carrying capacity as the base chain and should be avoided if possible.

Slow Speed Selection

If the linear chain speed (S) of the drive is less than or equal to 160 ft/min (50 meters/min) a one size smaller chain size can be selected by comparing the calculated chain tension to the chains "Rated Working Load" found in the "Chain Dimensions" tables for each chain size. The procedure is to calculate the linear chain speed (S) and then the calculated chain tension (T) by the following formulas

$$\begin{aligned} S &= (P \times n \times r) / 12 (\text{inches}) \\ &\text{or} \\ S &= (P \times n \times r) / 1000 (\text{millimeters}) \end{aligned}$$

$$\begin{aligned} S &= \text{Linear Chain Speed (ft/min or meters/min)} \\ P &= \text{Chain Pitch (inch or millimeters)} \\ n &= \text{Number of teeth on the small sprocket} \\ r &= \text{rpm of the small sprocket} \end{aligned}$$

$$\begin{aligned} T (\text{Lbs}) &= ((\text{DHP} \times 33,000) / S) \times F \\ &\text{or} \\ T (\text{Kg-F}) &= ((\text{DKW} \times 6,120) / S) \times F \end{aligned}$$

$$\begin{aligned} T &= \text{Calculated Chain Tension (lbs or kN)} \\ \text{DHP} &= \text{Design Horsepower} \\ \text{DKW} &= \text{Design Kilowatts} \\ F &= \text{Speed Correction Factor} \end{aligned}$$

Table 3: Speed Correction Factor

Chain Speed	Factor (F)
0 - 50 ft/min 0 - 15 meters/min	1.0
50 - 100 ft/min 15 - 30 meters/min	1.2
100 - 160 ft/min 30 - 45 meters/min	1.4

ASME/ANSI Drive Chain Selection

Quick Selector Chart

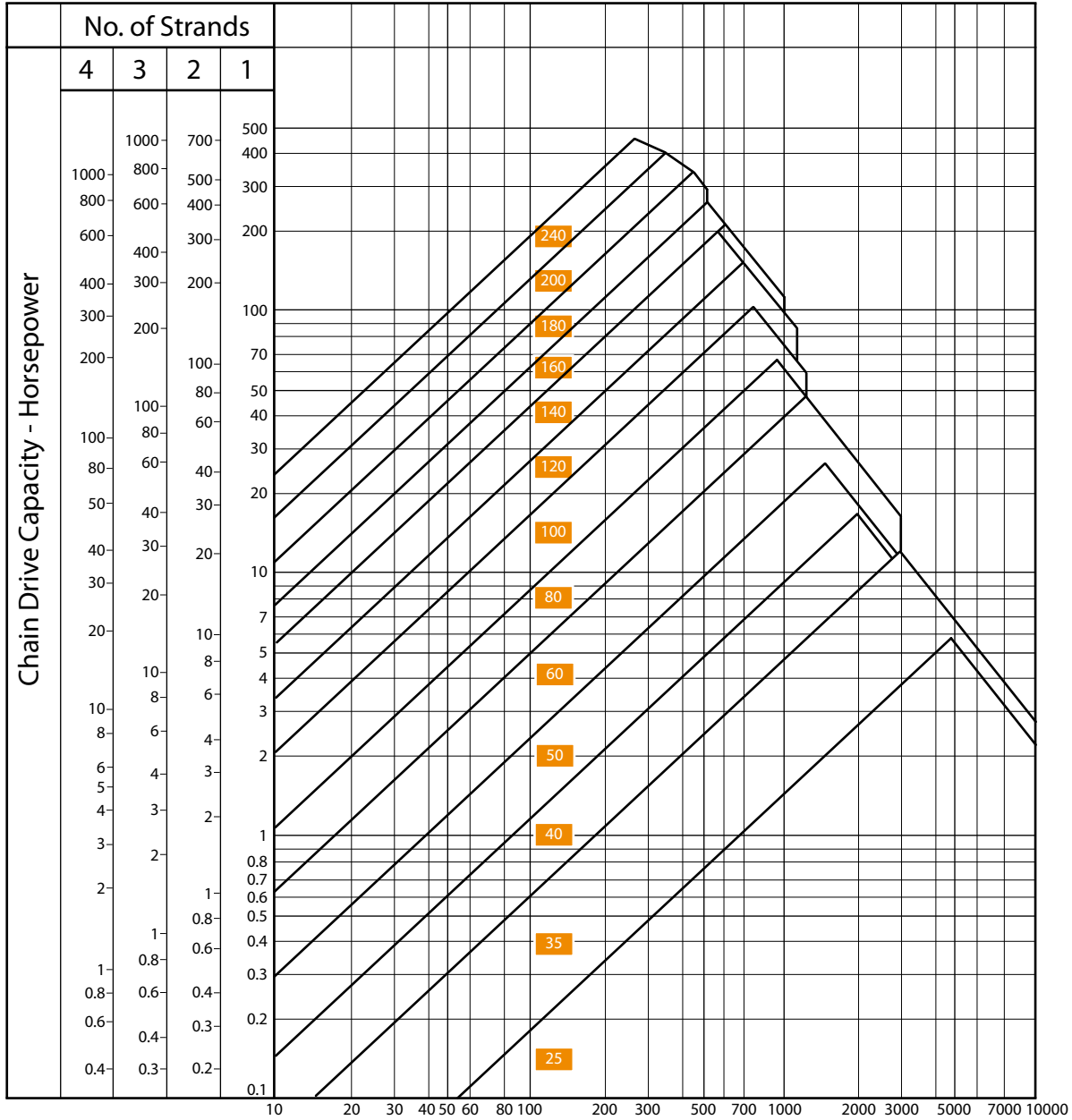

Note that the Quick Selector Chart uses Horsepower. To convert Kilowatts to Horsepower use the following formula:

$$\text{Horsepower} = \text{Kilowatts} \times 1.340$$

Thus to make the tentative selection from the Quick Selector Chart convert Kilowatts to Horsepower. After the tentative selection is made you can revert back to metric units.

ASME/ANSI Drive Chain Selection

Table 4: "K" Values for Calculating Chain Length (L)

N - n	K	N - n	K	N - n	K	N - n	K	N - n	K	N - n	K	N - n	K
1	0.03	21	11.17	41	42.58	61	94.25	81	166.19	101	258.39	121	370.86
2	0.10	22	12.26	42	44.68	62	97.37	82	170.32	102	263.54	122	377.02
3	0.23	23	13.40	43	46.84	63	100.54	83	174.50	103	268.73	123	383.22
4	0.41	24	14.59	44	49.04	64	103.75	84	178.73	104	273.97	124	389.48
5	0.63	25	15.83	45	51.29	65	107.02	85	183.01	105	279.27	125	395.79
6	0.91	26	17.12	46	53.60	66	110.34	86	187.34	106	284.67	126	402.14
7	1.24	27	18.47	47	55.95	67	113.71	87	191.73	107	290.01	127	408.55
8	1.62	28	19.86	48	58.36	68	117.13	88	196.16	108	295.45	128	415.01
9	2.05	29	21.30	49	60.82	69	120.60	89	200.64	109	300.95	129	421.52
10	2.53	30	22.80	50	63.33	70	124.12	90	205.18	110	306.50	130	428.08
11	3.06	31	24.34	51	65.88	71	127.69	91	209.76	111	312.09	131	434.69
12	3.65	32	25.94	52	68.49	72	131.31	92	214.40	112	317.74	132	441.36
13	4.28	33	27.58	53	71.15	73	134.09	93	219.08	113	323.44	133	448.07
14	4.96	34	29.28	54	73.86	74	138.71	94	223.82	114	329.19	134	454.83
15	5.70	35	31.03	55	76.62	75	142.48	95	228.61	115	334.99	135	461.64
16	6.48	36	32.83	56	79.44	76	146.31	96	233.44	116	340.84	136	468.51
17	7.32	37	34.68	57	82.30	77	150.18	97	238.33	117	346.75	137	475.42
18	8.21	38	36.58	58	85.21	78	154.11	98	243.27	118	352.70	138	482.39
19	9.14	39	38.53	59	88.17	79	158.09	99	248.26	119	358.70	139	489.41
20	10.13	40	40.53	60	91.19	80	162.11	100	253.30	120	364.76	140	496.47

Allowable Drive Configurations

Horizontal Drives

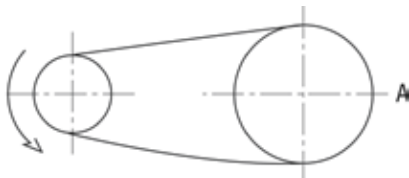

Slack side on bottom to provide self tensioning.

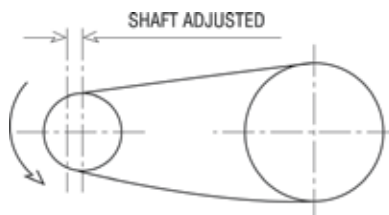

Short center distances (less than 20 pitches of chain) the shaft centers can be adjustable.

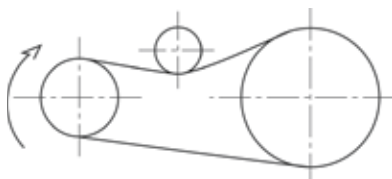

Chain tensioner is used when slack side is on the top.

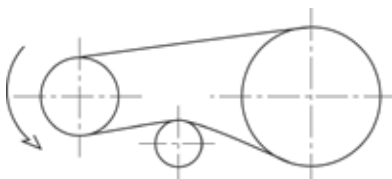

Chain tensioner is required when chain center distance is greater than 50 pitches.

Incline Drives

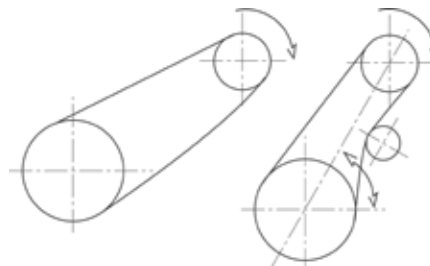

Chain tensioner is required if the inclined angle is greater than 60° or if too much slack causes the chain to fall away from the bottom sprocket.

Vertical Drives

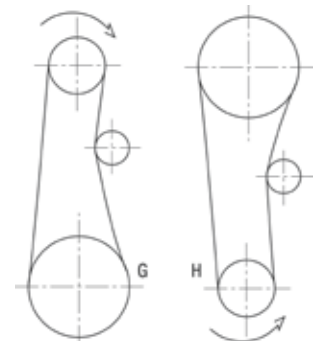

Chain tensioner is required regardless of the location of the small sprocket (Top or bottom)

06B British Standard ISO Roller Chain

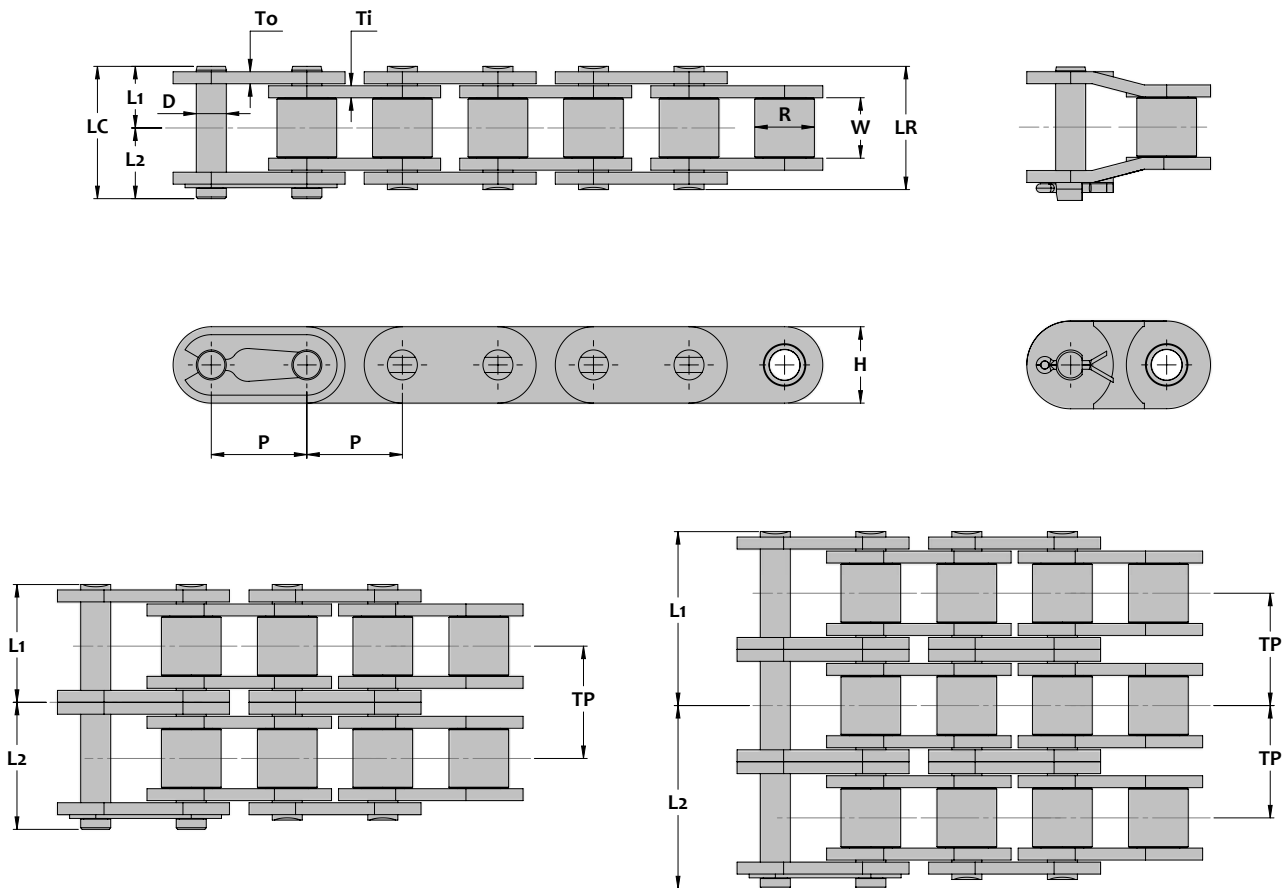

Chain Dimensions

Common Dimensions											
MAXCO Chain Number	Units	Chain Pitch P	Inside Width W	Bushing Diameter R	Pin Diameter D	Link Plate Thickness		Roller Link Plate Height H	Number of Links in 10ft/5m	Available Construction	
						Ti	To			Cot	Riv
06B	inch	0.375	0.225	0.250	0.130	0.050	0.040	0.323	320	No	Yes
	mm	9.525	5.72	6.35	3.28	1.25	1.0	8.2	526		
Pin Lengths and Chain Ratings											
MAXCO Chain Number	Units	Number of Strands	Pin Lengths				Transverse Pitch TP	Rated Working Load Lbs Kg-f	Minimum Ultimate Strength Lbs Kg-f	Average Ultimate Strength Lbs Kg-f	Average Chain Weight Lbs/ft Kg/m
			L1	L2	LR	LC					
06B	inch	1	0.25	0.28	0.50	0.53	-	400	2,000	2,200	0.27
	mm		6.3	7.1	12.6	13.4	-	182	909	1,000	0.41
06B-2	inch	2	0.45	0.48	0.90	0.93	0.403	680	3,800	4,360	0.52
	mm		11.4	12.3	22.9	23.7	10.24	309	1,725	1,980	0.78
06B-3	inch	3	0.65	0.67	1.31	1.33	0.403	950	5,600	6,430	0.79
	mm		16.6	17.1	33.2	33.7	10.24	432	2,545	2,925	1.18

08B British Standard ISO Roller Chain

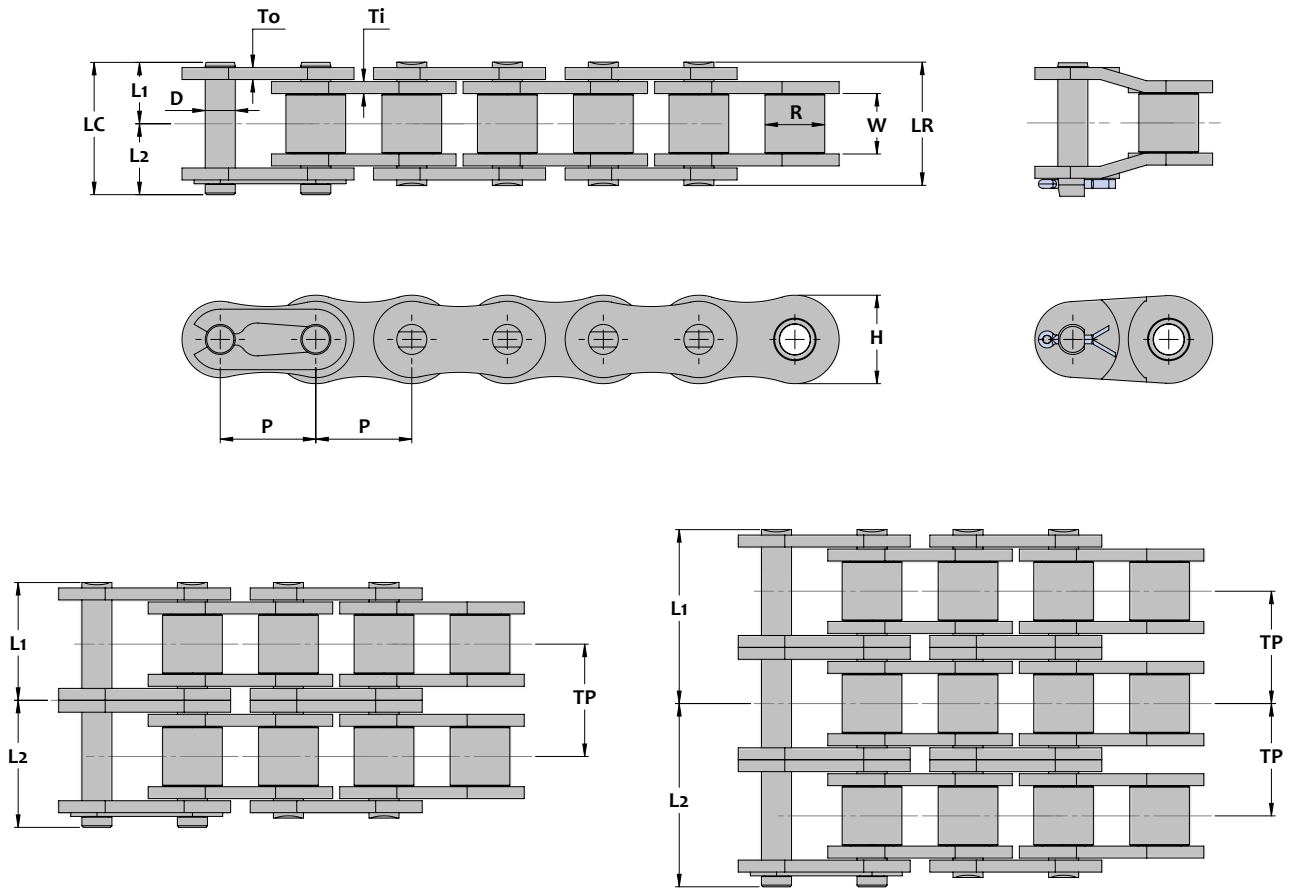

Chain Dimensions

MAXCO Chain Number	Units	Chain Pitch P	Common Dimensions							Available Construction	
			Inside Width W	Bushing Diameter R	Pin Diameter D	Link Plate Thickness		Roller Link Plate Height H	Number of Links in 10ft/5m	Cot	Riv
						Ti	To				
08B	inch	0.500	0.305	0.335	0.175	0.060		0.465	240	No	Yes
	mm	12.7	7.75	8.51	4.45	1.5		11.8			

MAXCO Chain Number	Units	Number of Strands	Pin Lengths				Transverse Pitch TP	Rated Working Load	Minimum Ultimate Strength	Average Ultimate Strength	Average Chain Weight
			L1	L2	LR	LC					
08B	inch	1	0.33	0.39	0.66	0.72	-	710	4,000	4,400	0.41
	mm		8.4	9.8	16.7	18.2	-	323	1,820	2,000	0.61
08B-2	inch	2	0.60	0.65	1.20	1.26	0.548	1,210	7,000	7,760	0.84
	mm		15.3	16.6	30.6	31.9	13.92	550	3,180	3,525	1.26
08B-3	inch	3	0.88	0.93	1.75	1.80	0.548	1,770	10,000	11,130	1.26
	mm		22.3	23.5	44.5	45.8	13.92	805	4,545	5,060	1.88

10B British Standard ISO Roller Chain

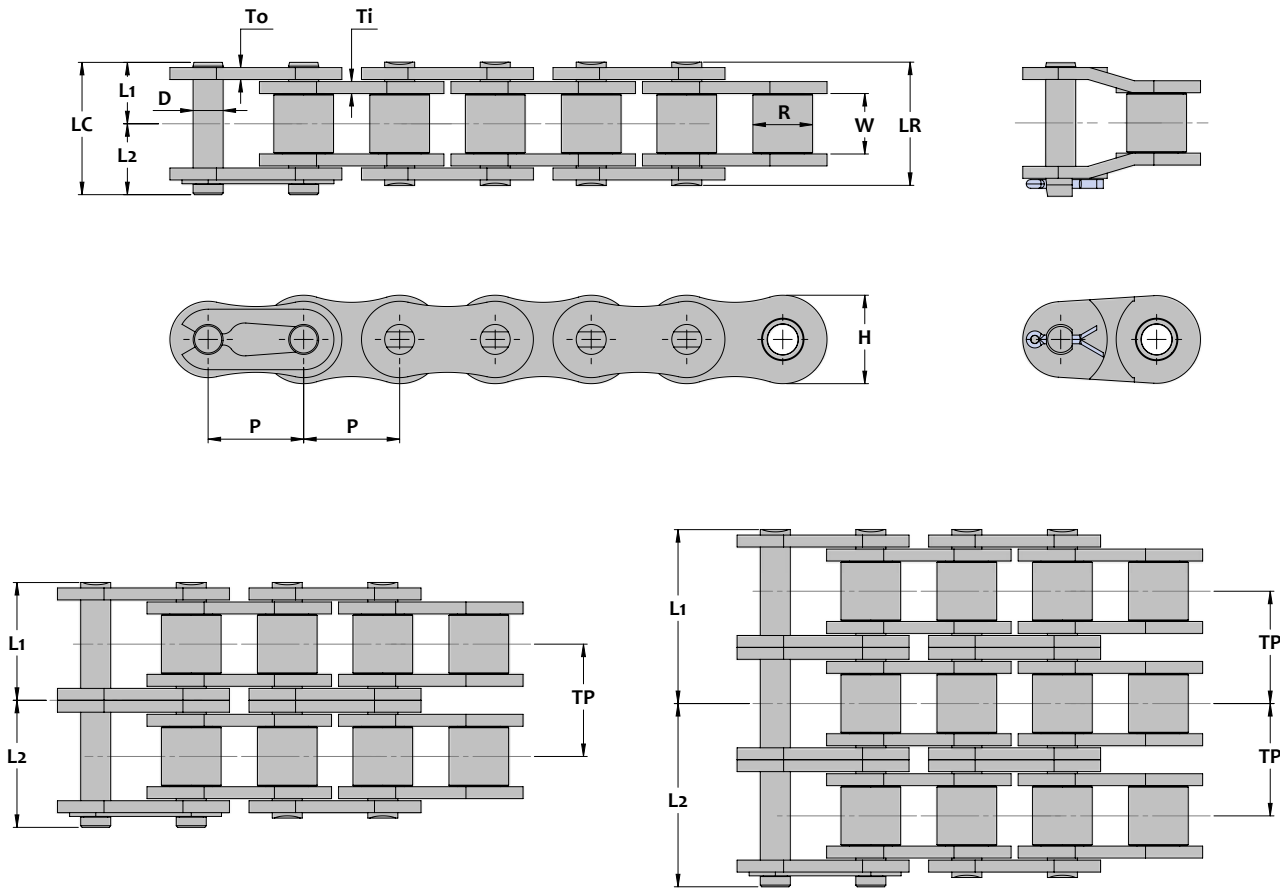

Chain Dimensions

MAXCO Chain Number	Units	Chain Pitch P	Common Dimensions							Available Construction	
			Inside Width W	Bushing Diameter R	Pin Diameter D	Link Plate Thickness		Roller Link Plate Height H	Number of Links in 10ft/5m	Cot	Riv
						Ti	To				
10B	inch	0.625	0.380	0.400	0.200	0.065		0.579	192	No	Yes
	mm	15.875	9.65	10.16	5.08	1.65		14.7			
MAXCO Chain Number	Units	Number of Strands	Pin Lengths				Transverse Pitch TP	Rated Working Load	Minimum Ultimate Strength	Average Ultimate Strength	Average Chain Weight
			L1	L2	LR	LC					
			Lbs Kg-f	Lbs Kg-f	Lbs Kg-f	Lbs/ft Kg/m					
10B	inch	1	0.37	0.44	0.75	0.81	-	1,100	5,000	5,600	0.60
	mm		9.5	11.2	19.0	20.7	-	500	2,275	2,545	0.89
10B-2	inch	2	0.70	0.77	1.40	1.47	0.653	1,880	10,000	11,200	1.20
	mm		17.8	19.5	35.6	37.3	16.59	855	4,545	5,090	1.79
10B-3	inch	3	1.03	1.11	2.06	2.14	0.653	2,750	15,000	16,790	1.78
	mm		26.2	28.2	52.4	54.4	16.59	1,250	6,820	7,630	2.66

12B British Standard ISO Roller Chain

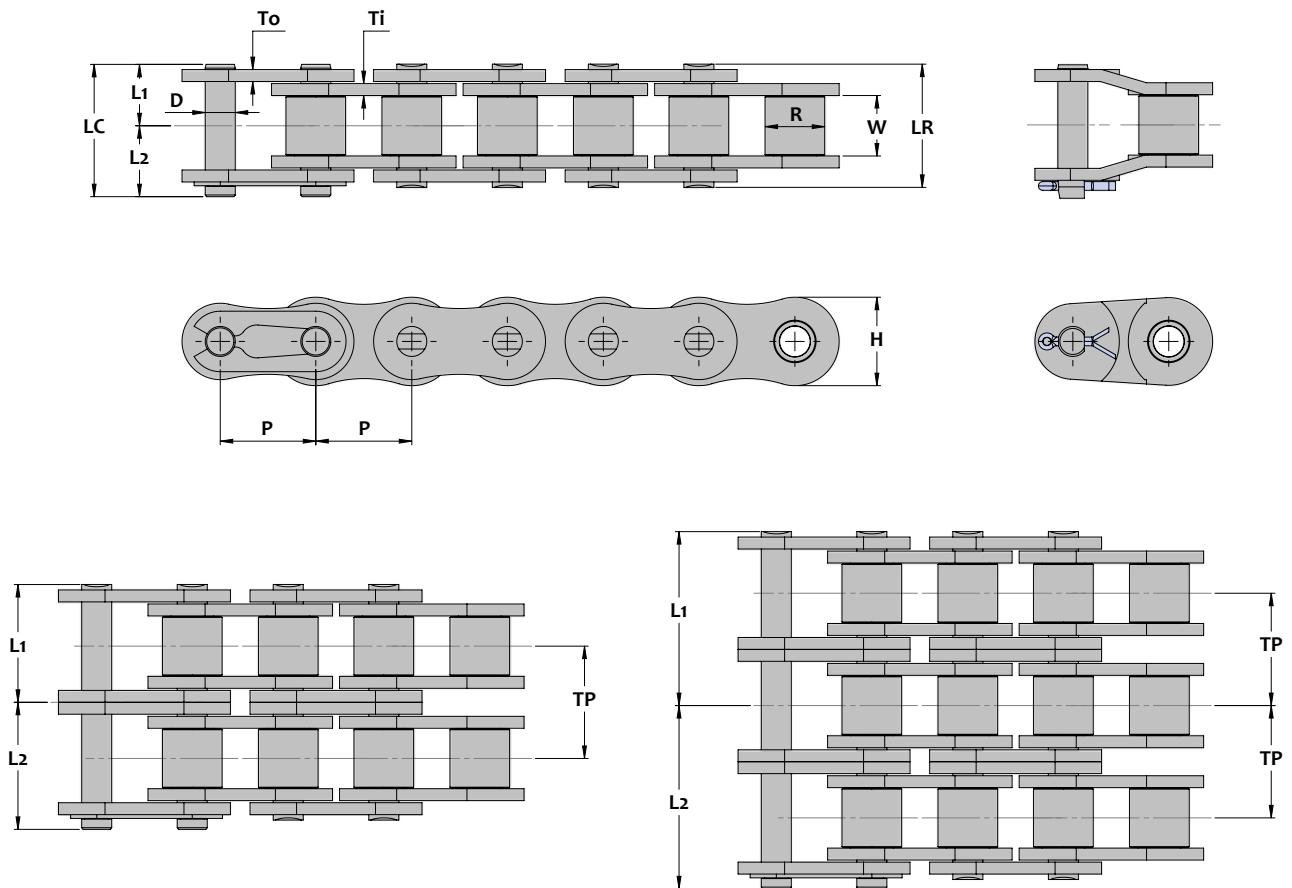

Chain Dimensions

MAXCO Chain Number	Units	Common Dimensions									Available Construction	
		Chain Pitch	Inside Width	Bushing Diameter	Pin Diameter	Link Plate Thickness		Roller Link Plate Height	Number of Links in 10ft/5m	Cot	Riv	
		P	W	R	D	Ti	To	H				
12B	inch mm	0.750 19.05	0.460 11.68	0.475 12.07	0.225 5.72	0.070 1.8		0.634 16.1	160 262	No	Yes	

MAXCO Chain Number	Units	Number of Strands	Pin Lengths				Transverse Pitch	Rated Working Load	Minimum Ultimate Strength	Average Ultimate Strength	Average Chain Weight
			L1	L2	LR	LC					
			Lbs Kg-f	Lbs Kg-f	Lbs Kg-f	Lbs/ft Kg/m					
12B	inch	1	0.43	0.50	0.87	0.93	-	1,590	6,500	7,190	0.76
	mm		11.0	12.6	22.0	23.6	-	723	2,955	3,270	1.14
12B-2	inch	2	0.82	0.88	1.64	1.70	0.766	2,700	13,000	14,390	1.53
	mm		20.8	22.3	41.6	43.1	19.46	1,225	5,910	6,540	2.28
12B-3	inch	3	1.20	1.26	2.41	2.47	0.766	3,960	19,500	21,580	2.25
	mm		30.6	32.1	61.1	62.7	19.46	1,800	8,865	9,810	3.36

16B British Standard ISO Roller Chain

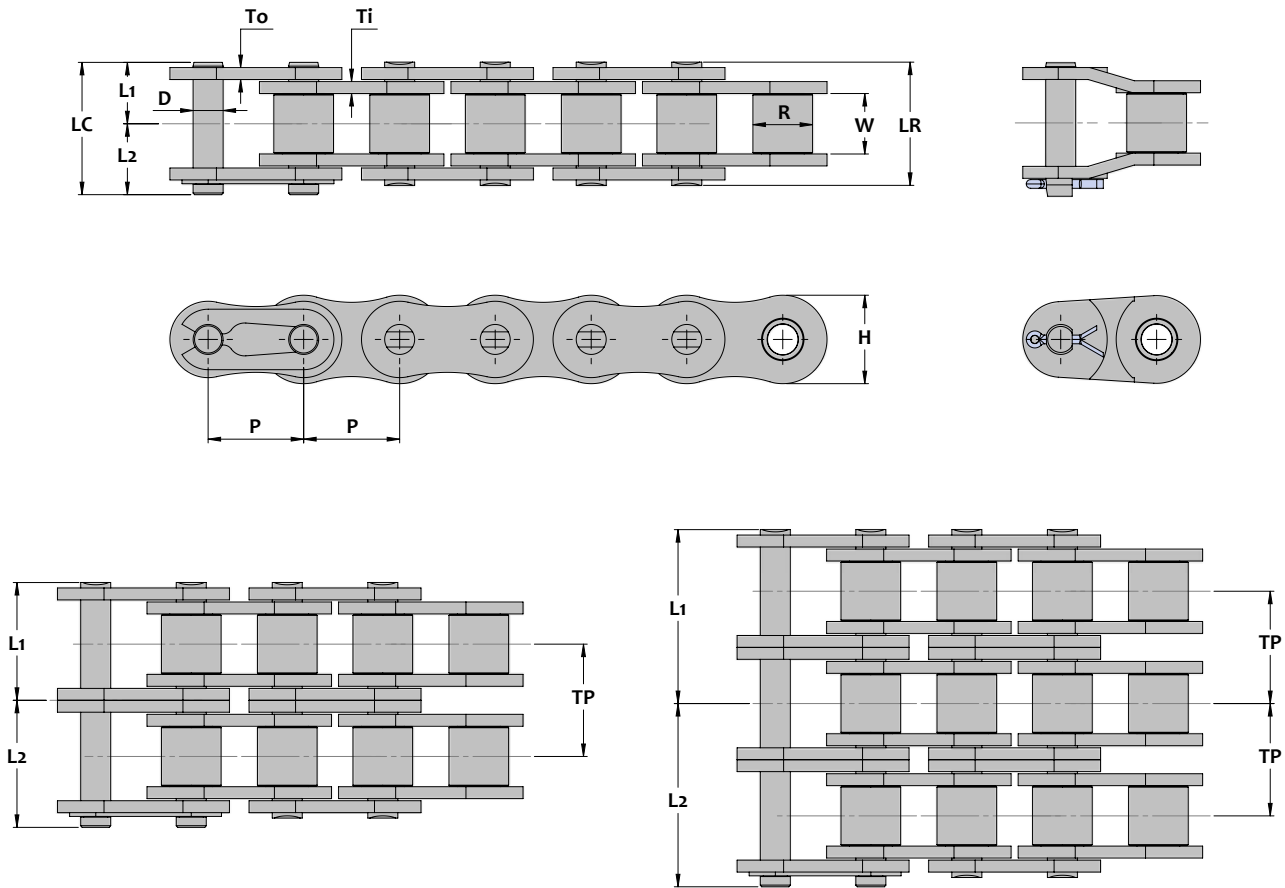

Chain Dimensions

MAXCO Chain Number	Units	Chain Pitch P	Common Dimensions							Number of Links in 10ft/5m	Available Construction	
			Inside Width W	Bushing Diameter R	Pin Diameter D	Link Plate Thickness		Roller Link Plate Height H	Cot		Riv	
						Ti	To					
16B	inch	1.000	0.670	0.625	0.325	0.157	0.125	0.827	120	No	Yes	
	mm	25.4	17.02	15.88	8.26	4.0	3.2	21.0	198			
MAXCO Chain Number	Units	Number of Strands	Pin Lengths				Transverse Pitch TP	Rated Working Load	Minimum Ultimate Strength	Average Ultimate Strength	Average Chain Weight	
			L1	L2	LR	LC						
			Lbs Kg-f	Lbs Kg-f	Lbs Kg-f	Lbs/ft Kg/m						
16B	inch	1	0.69	0.81	1.38	1.50	-	3,690	13,700	15,400	1.74	
	mm		17.6	20.6	35.1	38.2	-	1,675	6,225	7,000	2.59	
16B-2	inch	2	1.32	1.44	2.64	2.76	1.255	4,810	27,400	30,300	3.44	
	mm		33.6	36.5	67.2	70.1	31.88	2,185	12,455	13,775	5.13	
16B-3	inch	3	1.95	2.08	3.90	4.03	1.255	7,100	41,100	45,010	5.15	
	mm		49.6	52.9	99.2	102.5	31.88	3,225	18,682	20,460	7.68	

20B British Standard ISO Roller Chain

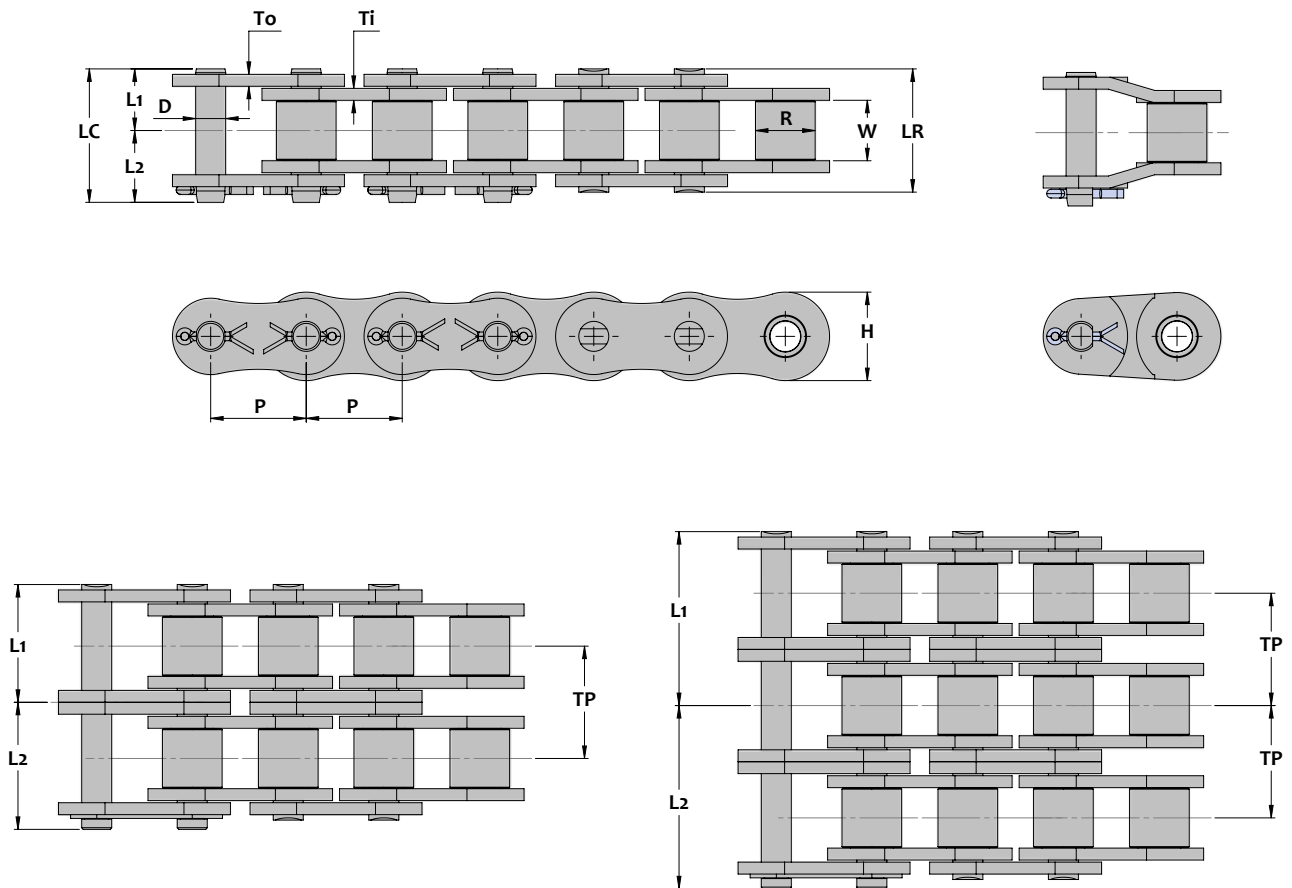

Chain Dimensions

MAXCO Chain Number	Units	Common Dimensions									
		Chain Pitch	Inside Width	Bushing Diameter	Pin Diameter	Link Plate Thickness		Roller Link Plate Height	Number of Links in 10ft/5m	Available Construction	
		P	W	R	D	Ti	To	H		Cot	Riv
20B	inch	1.250	0.770	0.750	0.400	0.177	0.138	1.039	96	Yes	Yes
	mm	31.75	19.56	19.05	10.16	4.5	3.5	26.4	158		

MAXCO Chain Number	Units	Number of Strands	Pin Lengths and Chain Ratings									
			Pin Lengths				Transverse Pitch	Rated Working Load	Minimum Ultimate Strength	Average Ultimate Strength	Average Chain Weight	
			L1	L2	LR	LC						TP
20B	inch	1	0.79	0.94	1.58	1.73	-	5,740	21,400	23,800	2.52	
	mm		20.1	23.9	40.2	44.0	-	2,610	9,725	10,820	3.76	
20B-2	inch	2	1.51	1.66	3.02	3.17	1.435	7,490	42,000	46,700	4.87	
	mm		38.4	42.2	76.8	80.6	36.45	3,405	19,090	21,225	7.26	
20B-3	inch	3	2.23	2.38	4.46	4.61	1.435	11,020	62,600	69,600	7.28	
	mm		56.7	60.5	113.4	117.2	36.45	5,010	28,455	31,635	10.9	

24B British Standard ISO Roller Chain

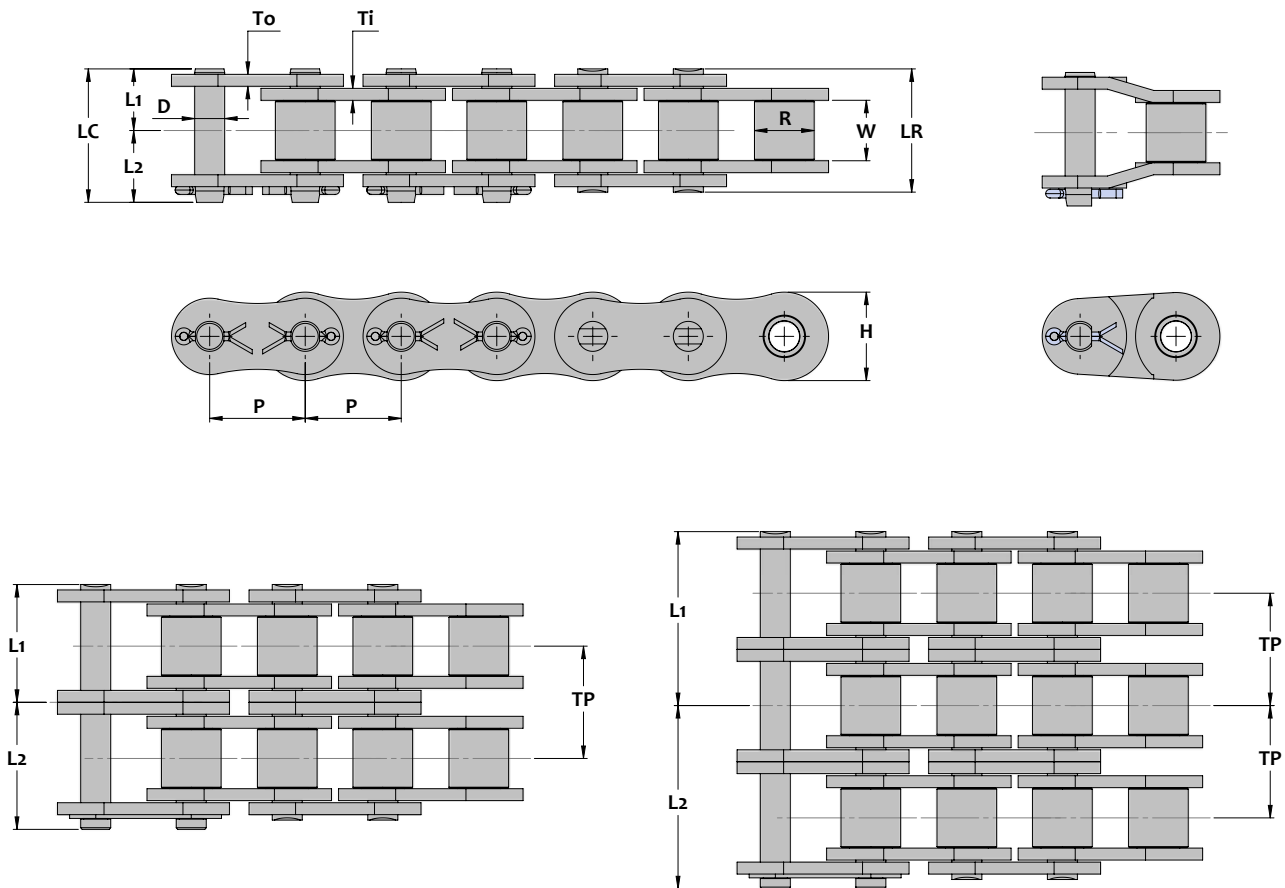

Chain Dimensions

MAXCO Chain Number	Units	Chain Pitch P	Common Dimensions							Number of Links in 10ft/5m	Available Construction	
			Inside Width W	Bushing Diameter R	Pin Diameter D	Link Plate Thickness		Roller Link Plate Height H	Cot		Riv	
						Ti	To					
24B	inch	1.500	1.000	1.000	0.576	0.232	0.193	1.315	80	Yes	Yes	
	mm	38.10	25.4	25.4	14.63	5.9	4.9	33.4	132			
MAXCO Chain Number	Units	Number of Strands	Pin Lengths				Transverse Pitch TP	Rated Working Load Lbs Kg-f	Minimum Ultimate Strength Lbs Kg-f	Average Ultimate Strength Lbs Kg-f	Average Chain Weight Lbs/ft Kg/m	
			L1	L2	LR	LC						
			24B	inch	1	1.05						1.24
mm	26.7	31.4	53.4	58.1	-	3,650	16,455	18,365	7.29			
24B-2	inch	2	2.00	2.19	4.00	4.19	1.904	10,520	72,400	80,800	9.74	
	mm	50.9	55.6	101.8	106.5	48.36	4,780	32,910	36,725	14.5		
24B-3	inch	3	2.96	3.14	5.92	6.10	1.904	15,470	108,600	121,200	14.6	
	mm	75.1	79.8	150.2	154.9	48.36	7,030	49,365	55,090	21.8		

28B British Standard ISO Roller Chain

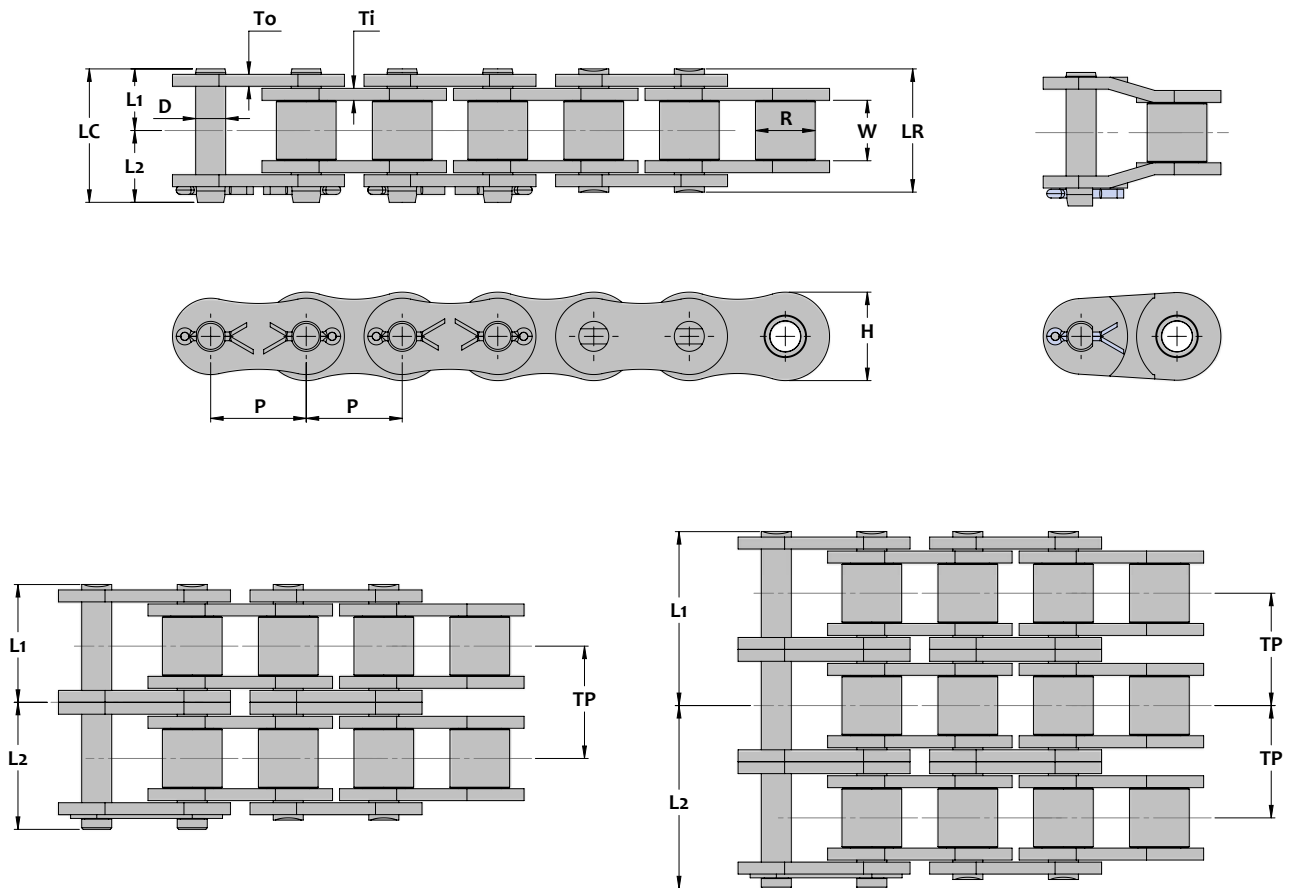

Chain Dimensions

MAXCO Chain Number	Units	Chain Pitch P	Common Dimensions						Roller Link Plate Height H	Number of Links in 10ft/5m	Available Construction	
			Inside Width W	Bushing Diameter R	Pin Diameter D	Link Plate Thickness		Cot			Riv	
						Ti	To					
28B	inch mm	1.750 44.45	1.220 31.00	1.100 27.94	0.625 15.88	0.291 7.4	0.248 6.3	1.457 37.0	70 116	Yes	Yes	

MAXCO Chain Number	Units	Number of Strands	Pin Lengths				Transverse Pitch TP	Rated Working Load	Minimum Ultimate Strength	Average Ultimate Strength	Average Chain Weight
			L1	L2	LR	LC					
			Lbs Kg-f	Lbs Kg-f	Lbs Kg-f	Lbs/ft Kg/m					
28B	inch	1	1.28	1.50	2.56	2.78	-	10,000	45,190	50,300	6.21
	mm		32.6	37.9	65.2	70.5	-	4,545	20,540	22,865	9.26
28B-2	inch	2	2.46	2.66	4.92	5.12	2.345	13,100	85,400	94,900	12.4
	mm		62.4	67.6	124.8	130.0	59.56	5,955	38,820	43,135	18.5
28B-3	inch	3	3.63	3.83	7.26	7.46	2.345	19,290	125,670	139,400	18.5
	mm		92.1	97.5	184.2	189.6	59.56	8,770	57,125	63,635	27.7

32B British Standard ISO Roller Chain

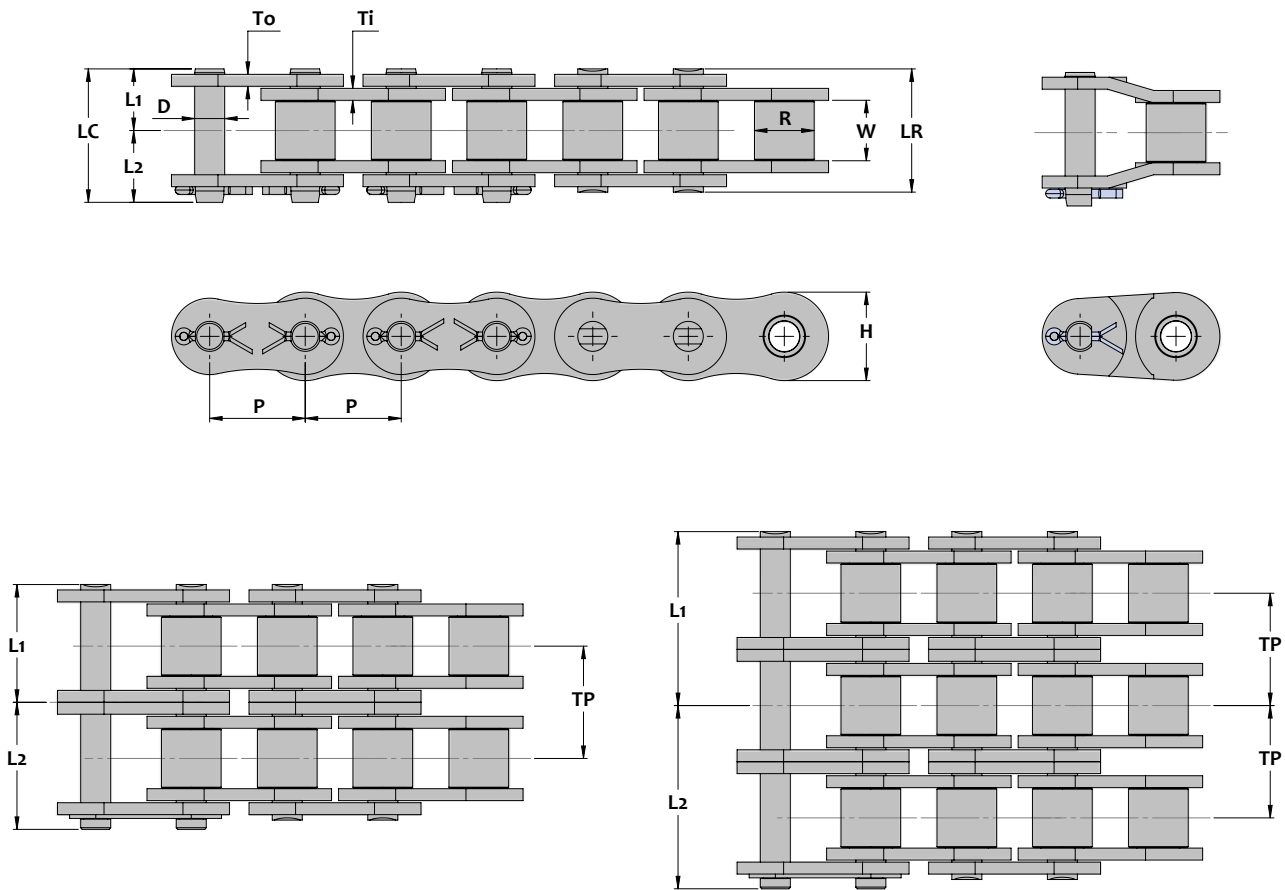

Chain Dimensions

MAXCO Chain Number	Units	Chain Pitch P	Common Dimensions							Number of Links in 10ft/5m	Available Construction	
			Inside Width W	Bushing Diameter R	Pin Diameter D	Link Plate Thickness		Roller Link Plate Height H	Cot		Riv	
						Ti	To					
32B	inch	2.000	1.220	1.150	0.700	0.272	0.248	1.661	60	Yes	Yes	
	mm	50.80	31.00	29.21	17.81	6.9	6.3	42.2	98			

MAXCO Chain Number	Units	Number of Strands	Pin Lengths				Transverse Pitch TP	Rated Working Load Lbs Kg-f	Minimum Ultimate Strength Lbs Kg-f	Average Ultimate Strength Lbs Kg-f	Average Chain Weight Lbs/ft Kg/m
			L1	L2	LR	LC					
			32B	inch	1	1.28					
mm	32.5	38.6		65.0		71.1	-	5,210	25,545	28,000	9.92
32B-2	inch	2	2.43	2.68	4.86	5.11	2.305	14,970	110,000	123,000	13.3
	mm		61.7	68.0	123.4	129.7	58.55	6,805	50,000	55,910	19.8
32B-3	inch	3	3.58	3.83	7.16	7.41	2.305	22,030	163,600	184,300	19.9
	mm		91.0	97.3	182.0	188.3	58.55	10,015	74,365	83,775	29.6

CRP Series - Chromium Treated Pin Chains

CRP Series chains possess Hard Chrome Plated pins in order to provide outstanding wear life. The surface hardness of the chromium layer is HV900 - HV1100 (Vickers Hardness) which can double or triple the working lifetime of standard ASME/ANSI roller chains even in highly abrasive applications. These chains operate on standard sprockets and possess the same working capacities in terms of loads or speeds as standard roller chains.

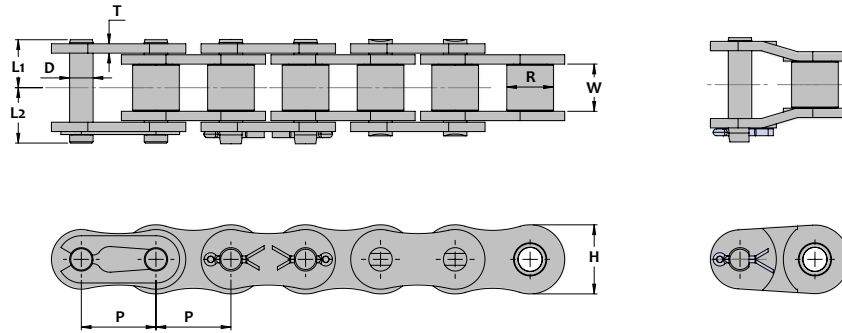

Chain Dimensions

MAXCO Chain Number	Units	Chain Pitch P	Roller		Pin					Side Plate		Rated Working Load Lbs Kg-f	Average Ultimate Strength Lbs Kg-f	Average Chain Weight Lbs/ft Kg/m
			Dia	Inside Width	Dia	Length				Height	Thick.			
			R	W	D	L1	L2	LR	LC	H	T			
40CRP	inch	0.500	0.312	0.312	0.157	0.32	0.41	0.64	0.73	0.475	0.060	815	4,190	0.42
	mm	12.70	7.92	7.92	3.98	8.2	10.3	16.4	18.5	12.06	1.52	370	1,905	0.62
50CRP	inch	0.625	0.400	0.375	0.200	0.40	0.49	0.80	0.89	0.594	0.080	1,400	6,830	0.68
	mm	15.88	10.16	9.52	5.09	10.2	12.4	20.4	22.6	15.08	2.03	636	3,105	1.01
60CRP	inch	0.750	0.469	0.500	0.235	0.50	0.60	1.00	1.10	0.712	0.094	2,090	9,260	0.97
	mm	19.05	11.91	12.70	5.96	12.5	15.3	25.0	27.8	18.09	2.39	950	4,210	1.45
80CRP	inch	1.000	0.625	0.625	0.313	0.65	0.73	1.30	1.38	0.950	0.125	3,310	17,600	1.71
	mm	25.40	15.88	15.88	7.94	16.5	18.5	33.0	35.0	24.13	3.18	1,505	8,000	2.55
100CRP	inch	1.250	0.750	0.750	0.376	0.78	0.95	1.56	1.73	1.187	0.156	5,070	23,350	2.65
	mm	31.75	19.05	19.05	9.54	19.8	24.1	39.6	43.9	30.2	3.96	2,305	10,615	3.95
120CRP	inch	1.500	0.875	1.000	0.437	1.01	1.17	2.02	2.18	1.425	0.187	6,830	34,390	3.78
	mm	38.10	22.23	25.40	11.11	25.5	29.8	51.0	55.3	36.2	4.75	3,105	15,630	5.64
140CRP	inch	1.750	1.000	1.000	0.500	1.07	1.27	2.14	2.34	1.662	0.219	9,040	46,300	4.95
	mm	44.45	25.40	25.40	12.71	27.3	32.2	54.6	59.5	42.2	5.56	4,110	21,045	7.38
160CRP	inch	2.000	1.125	1.250	0.563	1.29	1.46	2.58	2.75	1.900	0.250	11,900	57,760	6.30
	mm	50.80	28.58	31.75	14.29	32.8	37.1	65.6	69.9	48.26	6.35	5,410	26,255	9.40
180CRP	inch	2.250	1.406	1.406	0.687	1.44	1.66	2.88	3.10	2.137	0.281	13,670	81,000	8.50
	mm	57.15	35.71	35.71	17.46	36.6	42.1	73.2	78.7	54.29	7.14	6,215	37,045	12.7
200CRP	inch	2.500	1.562	1.500	0.781	1.59	1.82	3.18	3.41	2.375	0.312	16,090	104,000	10.7
	mm	63.50	39.67	38.10	19.85	40.4	46.4	80.8	86.8	60.32	7.92	7,315	47,725	15.9

ASME/ANSI Transmission Series Double Pitch Roller Chain

Double Pitch roller chains are produced in accordance with the ASME/ANSI B29.3 (Transmission Series) and B29.4 (Conveyor Series) American roller chain standards. In general these chains are similar to ASME/ANSI standard products except that the pitch is double. They are available in Transmission Series, Conveyor Series with Standard (small) Rollers and Conveyor Series with Large (oversized) Rollers.

Transmission Series

This series is often used on drives with slow to moderate speeds, low chain loads and long center distances. Side plates have a figure "8" contour. The chain number is obtained by adding 2000 to the ASME/ANSI chain number and the prefix letter "A". Note that some companies do not use a prefix letter for this series so the chains may be represented as A2040, A2050 etc. or 2040, 2050 etc.

Conveyor Series with Standard (small) Rollers

This series is often used on light to moderate load material handling conveyors with or without attachment links. The side plate contour is straight for improved sliding properties. Pitch sizes of 1-1/2" and larger have "Heavy" series link plates (i.e. link plates of the next larger chain size). The chain number is found by adding 2000 to the ASME/ANSI chain number and the prefix letter "C". Chains with the "heavy" type side plates use a suffix letter "H".

Conveyor Series with Large (oversized) Rollers

These chains possess large rollers so that the chain rolls on a conveyor track reducing friction. Chain numbers are found in the same way as noted above except that the last digit on the chain number is changed from "0" to "2" which denotes the large roller.

Sprockets

In general sprockets should be produced specially for these chains according to the ASME/ANSI B29.3 and B29.4 standards however, for Transmission Series and Conveyor Series with Standard (small) Rollers, ASME/ANSI B29.1 Standard roller chain sprockets may be used provided the number of teeth is 30 or more.

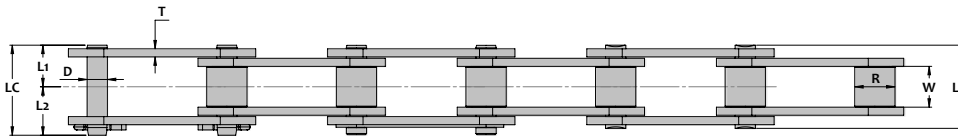

Transmission Series

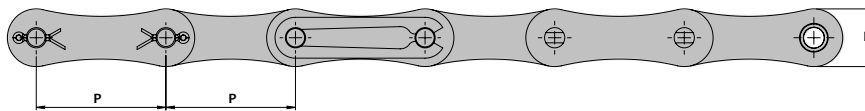

Chain Dimensions

MAXCO Chain Number	Units	Chain Pitch P	Roller		Pin					Side Plate		Average Ultimate Strength Lbs Kg-f	Rated Working Load Lbs Kg-f	Average Chain Weight Lbs/ft Kg/m
			Dia. R	Inside Width W	Dia. D	Length				Height H	Thick. T			
						L1	L2	LR	LC					
A2040	inch	1.000	0.312	0.313	0.156	0.33	0.38	0.65	0.70	0.449	0.060	3,800	815	0.29
	mm	25.40	7.92	7.95	3.96	8.3	9.6	16.6	17.9	11.4	1.5	1,725	370	0.43
A2050	inch	1.250	0.400	0.375	0.200	0.40	0.46	0.80	0.87	0.591	0.080	6,200	1,410	0.49
	mm	31.75	10.16	9.53	5.08	10.2	11.8	20.4	22.0	15.0	2.0	2,820	641	0.73
A2060	inch	1.500	0.469	0.500	0.234	0.50	0.56	1.01	1.06	0.669	0.094	9,050	1,940	0.69
	mm	38.10	11.91	12.70	5.95	12.8	14.1	25.6	26.9	17.0	2.4	4,115	882	1.03
A2080	inch	2.000	0.625	0.625	0.312	0.65	0.74	1.29	1.39	0.890	0.126	15,500	3,305	1.15
	mm	50.80	15.88	15.88	7.93	16.4	18.8	32.8	35.2	22.6	3.2	7,045	1,500	1.71

ASME/ANSI Conveyor Series Double Pitch Roller Chain

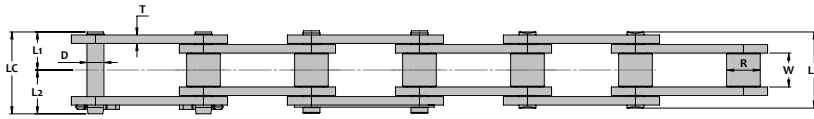

Standard Roller

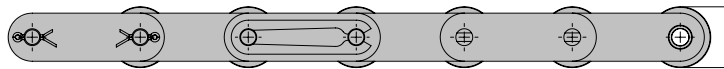
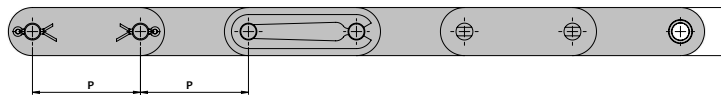

Large Roller

Chain Dimensions - Standard Roller

MAXCO Chain Number	Units	Chain Pitch P	Roller		Dia D	Pin				Side Plate		Average Ultimate Strength Lbs Kg-f	Rated Working Load Lbs Kg-f	Average Chain Weight Lbs/ft Kg/m
			Dia R	Inside Width W		Length	Height H	Thick. T						
									L1	L2	LR			
C2040	inch	1.000	0.312	0.313	0.156	0.32	0.41	0.65	0.73	0.449	0.060	3,800	815	0.32
	mm	25.40	7.92	7.95	3.96	8.2	10.3	16.4	18.5	11.4	1.5	1,725	370	0.48
C2050	inch	1.250	0.400	0.375	0.200	0.40	0.46	0.80	0.87	0.591	0.080	6,200	1,410	0.55
	mm	31.75	10.16	9.53	5.08	10.2	11.8	20.4	22.0	15.0	2.0	2,820	641	0.82
C2060H	inch	1.500	0.469	0.500	0.234	0.57	0.65	1.13	1.22	0.669	0.126	9,050	1,940	0.93
	mm	38.10	11.91	12.70	5.95	14.4	16.6	28.8	31.0	17.0	3.2	4,115	882	1.38
C2080H	inch	2.000	0.625	0.625	0.312	0.70	0.83	1.40	1.53	0.890	0.157	15,500	3,305	1.56
	mm	50.80	15.88	15.88	7.93	17.8	21.0	35.6	38.8	22.6	4.0	7,045	1,500	2.32
C2100H	inch	2.500	0.750	0.750	0.375	0.83	0.97	1.66	1.80	1.126	0.189	24,300	5,080	2.32
	mm	63.50	19.05	19.05	9.53	21.1	24.6	42.2	45.7	28.6	4.8	11,045	2,310	3.46
C2120H	inch	3.000	0.875	1.000	0.437	1.04	1.21	2.07	2.24	1.374	0.220	34,000	6,830	3.30
	mm	76.20	22.23	25.40	11.10	26.3	30.7	52.6	57.0	34.9	5.6	15,455	3,105	4.92
C2160H	inch	4.000	1.125	1.250	0.562	1.33	1.54	2.67	2.87	1.874	0.283	58,000	11,910	5.38
	mm	101.60	28.58	31.75	14.28	33.9	39.0	67.8	72.9	47.6	7.2	26,365	5,415	8.02

Chain Dimensions - Large Roller

C2042	inch	1.000	0.625	0.313	0.156	0.32	0.41	0.65	0.73	0.449	0.060	3,800	815	0.55
	mm	25.40	15.88	7.95	3.96	8.2	10.3	16.4	18.5	11.4	1.5	1,725	370	0.82
C2052	inch	1.250	0.750	0.375	0.200	0.40	0.46	0.80	0.87	0.591	0.080	6,200	1,410	0.84
	mm	31.75	19.05	9.53	5.08	10.2	11.8	20.4	22.0	15.0	2.0	2,820	641	1.26
C2062H	inch	1.500	0.875	0.500	0.234	0.57	0.65	1.13	1.22	0.669	0.126	9,050	1,940	1.39
	mm	38.10	22.23	12.70	5.95	14.4	16.6	28.8	31.0	17.0	3.2	4,115	882	2.08
C2082H	inch	2.000	1.125	0.625	0.312	0.70	0.83	1.40	1.53	0.890	0.157	15,500	3,305	2.25
	mm	50.80	28.58	15.88	7.93	17.8	21.0	35.6	38.8	22.6	4.0	7,045	1,500	3.36
C2102H	inch	2.500	1.562	0.750	0.375	0.83	0.97	1.66	1.80	1.126	0.189	24,300	5,080	3.78
	mm	63.50	39.67	19.05	9.53	21.1	24.6	42.2	45.7	28.6	4.8	11,045	2,310	5.64
C2122H	inch	3.000	1.750	1.000	0.437	1.04	1.21	2.07	2.24	1.374	0.220	34,000	6,830	5.28
	mm	76.20	44.45	25.40	11.10	26.3	30.7	52.6	57.0	34.9	5.6	15,455	3,105	7.87
C2162H	inch	4.000	2.250	1.250	0.562	1.33	1.54	2.67	2.87	1.874	0.283	58,000	11,910	8.56
	mm	101.60	57.15	31.75	14.28	33.9	39.0	67.8	72.9	47.6	7.2	26,365	5,415	12.8

ASME/ANSI Straight (Flat) Side Bar Roller Chain

ASME/ANSI Straight (Flat) Side Bar roller chains are identical to ASME/ANSI standard chains except that the side bar is straight (flat) rather than contoured. These chains are most often used for light to moderate duty material handling conveyors where the side bars are allowed to slide on a conveyor track. The straight side bar design also allows unit materials to sit on top of the chains easily in conveyor applications. The suffix "F" is used after the chain number to denote this series.

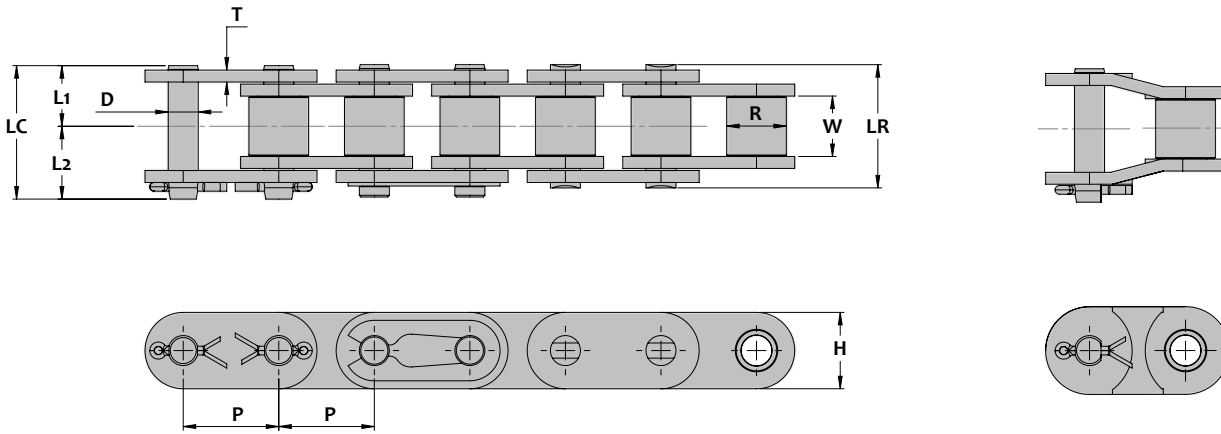

Chain Dimensions

MAXCO Chain Number	Units	Chain Pitch P	Roller		Dia D	Pin				Side Plate		Average Ultimate Strength Lbs Kg-f	Rated Working Load Lbs Kg-f	Average Chain Weight Lbs/ft Kg/m
			Dia R	Inside Width W		Length L1	Length L2	Length LR	Length LC	Height H	Thick. T			
35F	inch	0.375	0.200	0.188	0.141	0.24	0.27	0.47	0.51	0.354	0.050	2,430	500	0.25
	mm	9.525	5.08	4.78	3.58	6.0	6.9	12.0	12.9	9.0	1.25	1,105	227	0.38
40F	inch	0.500	0.312	0.313	0.156	0.33	0.37	0.65	0.70	0.461	0.060	4,300	935	0.45
	mm	12.70	7.92	7.95	3.96	8.3	9.4	16.6	17.7	11.7	1.5	1,955	425	0.67
50F	inch	0.750	0.400	0.375	0.200	0.40	0.46	0.80	0.86	0.575	0.080	7,200	1,625	0.74
	mm	19.05	10.16	9.53	5.08	11.7	11.7	20.4	21.9	14.6	2.0	3,275	739	1.10
60F	inch	0.750	0.469	0.500	0.234	0.50	0.56	1.01	1.06	0.689	0.094	10,000	2,405	1.09
	mm	19.05	11.91	12.70	5.94	12.8	14.1	25.6	26.9	17.5	2.4	4,545	1,095	1.63
80F	inch	1.000	0.625	0.625	0.312	0.65	0.75	1.29	1.40	0.921	0.126	17,650	4,135	1.89
	mm	25.40	15.88	15.88	7.92	16.4	19.1	32.8	35.5	23.4	3.2	8,025	1,880	2.82
100F	inch	1.250	0.750	0.750	0.375	0.78	0.92	1.55	1.69	1.154	0.157	26,500	6,360	2.93
	mm	31.75	19.05	19.05	9.53	19.7	23.3	39.4	43.0	29.3	4.0	12,045	2,890	4.37
120F	inch	1.500	0.875	1.000	0.437	0.98	1.13	1.95	2.10	1.382	0.188	39,000	8,545	4.33
	mm	38.10	22.23	25.40	11.10	24.8	28.6	49.6	53.4	35.1	4.8	17,725	3,885	6.45
140F	inch	1.750	1.000	1.000	0.500	1.06	1.23	2.13	2.30	1.610	0.220	48,600	11,310	5.56
	mm	44.45	25.40	25.40	12.70	27.0	31.3	54.0	58.3	40.9	5.6	22,090	5,140	8.29
160F	inch	2.000	1.125	1.250	0.562	1.27	1.44	2.54	2.7	1.839	0.250	63,000	14,900	7.35
	mm	50.80	28.58	31.75	14.27	32.2	36.5	64.4	68.7	46.7	6.4	28,635	6,775	11.0
200F	inch	2.500	1.562	1.500	0.781	1.55	1.88	3.09	3.43	2.354	0.315	105,000	18,500	12.7
	mm	63.50	39.67	38.10	19.84	39.3	47.7	78.6	87.0	59.8	8.0	47,725	8,410	19.0
240F	inch	3.000	1.875	1.875	0.936	1.90	2.20	3.80	4.10	2.768	0.374	152,200	25,360	17.8
	mm	76.20	47.63	47.63	23.78	48.2	55.9	96.4	104.1	70.3	9.5	69,180	11,525	26.5

ISO 606B British Standard Straight (Flat) Side Bar Roller Chain

ISO 606B British Standard Straight (Flat) Side Bar roller chains are identical to ISO 606B British Standard chains except that the side bar is straight (flat) rather than contoured. These chains are most often used for light to moderate duty material handling conveyors where the side bars are allowed to slide on a conveyor track. The straight side bar design also allows unit materials to sit on top of the chains easily in conveyor applications. The suffix "F" is used after the chain number to denote this series.

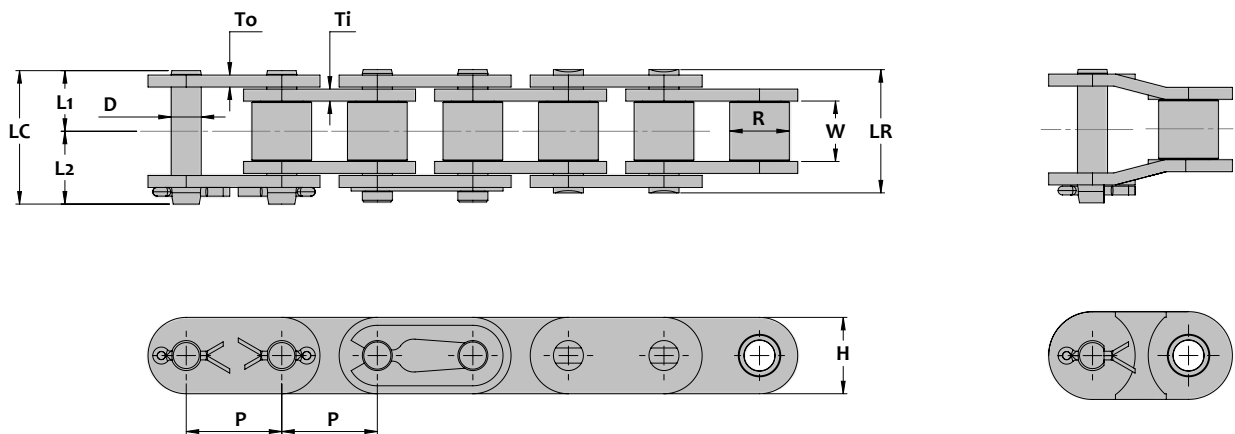

Chain Dimensions

MAXCO Chain Number	Units	Chain Pitch P	Roller		Pin					Side Plate		Average Ultimate Strength Lbs Kg-f	Rated Working Load Lbs Kg-f	Average Chain Weight Lbs/ft Kg/m	
			Inside Width W	Dia R	Dia D	Length				Height H	Thickness				
						L1	L2	LR	LC		Ti				To
08BF	inch	0.500	0.305	0.335	0.175	0.33	0.38	0.66	0.71	0.465	0.060	4,400	710	0.46	
	mm	12.70	8.51	8.51	4.45	8.4	9.6	16.8	18.0	11.8	1.50	2,000	323	0.68	
10BF	inch	0.625	0.380	0.400	0.200	0.37	0.44	0.75	0.81	0.579	0.065	5,600	1,100	0.66	
	mm	15.875	9.65	10.16	5.08	9.5	11.2	19.0	20.7	14.7	1.65	2,545	500	0.99	
12BF	inch	0.750	0.460	0.475	0.225	0.43	0.50	0.87	0.93	0.634	0.071	7,190	1,590	0.85	
	mm	19.05	11.68	12.07	5.72	11.0	12.6	22.0	23.6	16.1	1.8	3,270	723	1.27	
16BF	inch	1.000	0.673	0.625	0.325	0.69	0.81	1.39	1.50	0.921	0.157	0.125	15,400	2,835	1.94
	mm	25.40	17.1	15.88	8.26	17.6	20.5	35.2	38.1	23.4	4.0	3.2	7,000	1,290	2.90
20BF	inch	1.250	0.772	0.750	0.400	0.79	0.94	1.58	1.73	1.154	0.177	0.138	23,800	4,405	2.82
	mm	31.75	19.6	19.05	10.16	20.1	23.9	40.2	44.0	29.3	4.5	3.5	10,820	2,000	4.21
24BF	inch	1.500	1.000	1.000	0.576	1.05	1.24	2.10	2.29	1.382	0.232	0.193	40,400	6,180	5.47
	mm	38.10	25.4	25.40	14.63	26.7	31.4	53.4	58.1	35.1	5.9	4.9	18,365	2,810	8.16
28BF	inch	1.750	1.220	1.100	0.625	1.28	1.49	2.57	2.78	1.610	0.291	0.248	50,300	7,710	6.95
	mm	44.45	31.0	27.94	15.88	32.6	37.9	65.2	70.5	40.9	7.4	6.3	22,865	3,505	10.4
32BF	inch	2.000	1.244	1.125	0.701	1.28	1.52	2.56	2.80	1.839	0.272	0.248	61,600	8,815	7.45
	mm	50.80	31.6	28.58	17.81	32.5	38.6	65.0	71.1	46.7	6.9	6.3	28,000	4,005	11.1

ASME/ANSI Heavy (H) Series Roller Chain

Heavy Series roller chains are built for power transmission applications that require additional shock load capacity or link plate strength. They are dimensionally equivalent to ASME/ANSI standard chains except that link plates are one size thicker. Single strand chains operate on standard sprockets however multiple strand chains require special sprockets due to their increased transverse pitch. The suffix "H" is used after the chain number to denote this series.

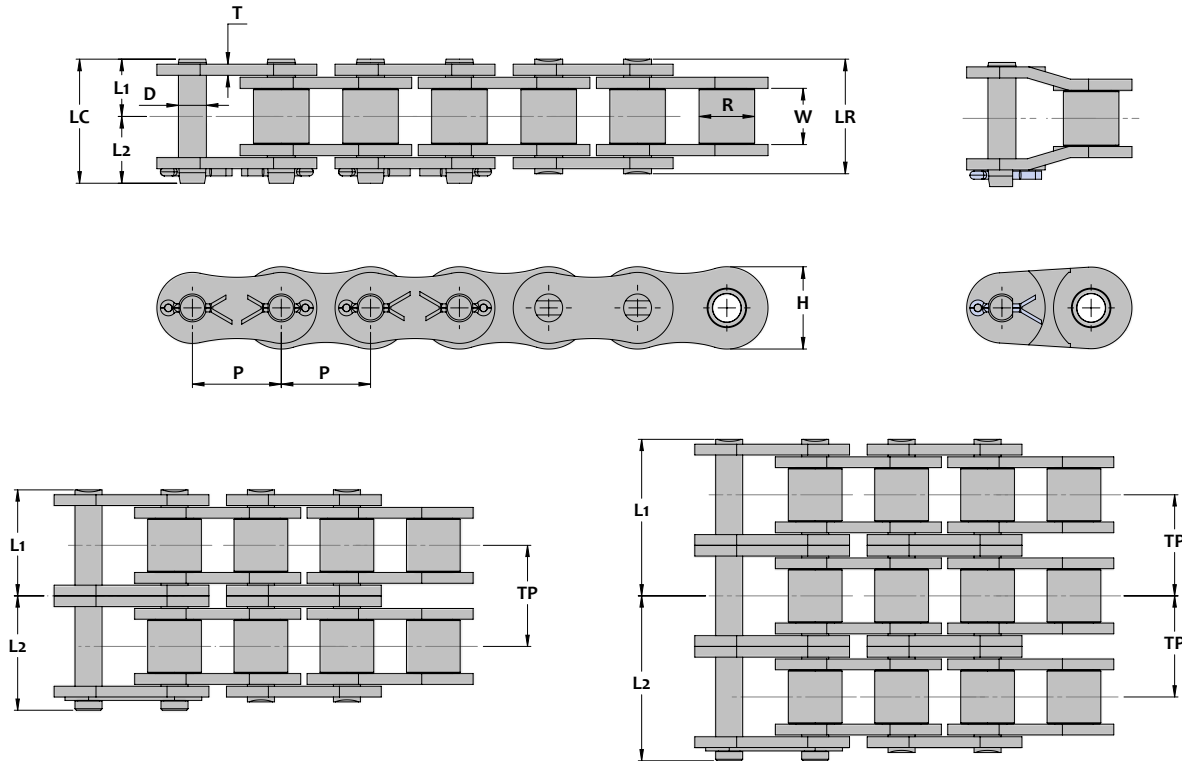

Chain Dimensions - Single Strand

MAXCO Chain Number	Units	Chain Pitch P	Roller		Dia D	Pin				Side Plate		Average Ultimate Strength Lbs Kg-f	Rated Working Load Lbs Kg-f	Average Chain Weight Lbs/ft Kg/m
			Dia R	Inside Width W		Length				Height H	Thick. T			
						L1	L2	LR	LC					
60H	inch	0.750	0.469	0.500	0.234	0.57	0.65	1.13	1.21	0.689	0.126	12,300	2,405	1.21
	mm	19.05	11.91	12.70	5.94	14.4	16.4	28.8	30.8	17.5	3.2	5,590	1,095	1.80
80H	inch	1.000	0.625	0.625	0.312	0.70	0.82	1.41	1.52	0.921	0.157	20,300	4,135	1.88
	mm	25.40	15.88	15.88	7.92	17.9	20.8	35.7	38.7	23.4	4.0	9,225	1,880	2.81
100H	inch	1.250	0.750	0.750	0.375	0.83	0.97	1.67	1.81	1.154	0.188	30,800	6,360	2.78
	mm	31.75	19.05	19.05	9.53	21.2	24.7	42.4	45.9	29.3	4.8	14,000	2,890	4.14
120H	inch	1.500	0.875	1.000	0.437	1.04	1.21	2.08	2.25	1.382	0.220	41,800	8,540	3.91
	mm	38.10	22.23	25.40	11.10	26.4	30.8	52.8	57.2	35.1	5.6	19,000	3,880	5.83
140H	inch	1.750	1.000	1.000	0.500	1.13	1.31	2.25	2.43	1.610	0.250	54,200	11,310	5.64
	mm	44.45	25.40	25.40	12.70	28.6	33.2	57.2	61.8	40.9	6.4	24,635	5,140	8.41
160H	inch	2.000	1.125	1.250	0.562	1.34	1.54	2.68	2.87	1.839	0.283	68,800	14,900	7.28
	mm	50.80	28.58	31.75	14.27	34.0	39.0	67.9	73.0	46.7	7.2	31,275	6,775	10.9
180H	inch	2.250	1.406	1.406	0.687	1.49	1.72	2.98	3.21	2.067	0.315	83,900	15,870	10.2
	mm	57.15	35.71	35.71	17.45	37.8	43.7	75.6	81.5	52.5	8.0	38,135	7,215	15.2
200H	inch	2.500	1.562	1.500	0.781	1.67	2.01	3.34	3.68	2.354	0.374	116,900	18,500	12.0
	mm	63.50	39.67	38.10	19.84	42.4	51.0	84.8	93.4	59.8	9.5	53,135	8,410	17.9

ASME/ANSI Heavy (H) Series Roller Chain

Chain Dimensions - Double Strand

MAXCO Chain Number	Units	Chain Pitch P	Roller			Pin				Side Plate		Trans. Pitch TP	Average Ultimate Strength Lbs Kg-f	Rated Working Load Lbs Kg-f	Average Chain Weight Lbs/ft Kg/m
			Dia R	Inside Width W	Dia D	Length				Height H	Thick. T				
						L1	L2	LR	LC						
60H-2	inch	0.750	0.469	0.500	0.234	1.08	1.17	2.16	2.24	0.689	0.126	1.028	24,600	3,415	2.41
	mm	19.05	11.91	12.70	5.94	27.4	29.6	54.8	57.0	17.5	3.2	26.1	11,180	1,550	3.59
80H-2	inch	1.000	0.625	0.625	0.312	1.35	1.46	2.69	2.81	0.921	0.157	1.283	40,600	5,800	3.71
	mm	25.40	15.88	15.88	7.92	34.2	37.1	68.4	71.3	23.4	4.0	32.6	18,455	2,635	5.54
100H-2	inch	1.250	0.750	0.750	0.375	1.61	1.74	3.21	3.35	1.154	0.188	1.539	61,600	8,790	5.5
	mm	31.75	19.05	19.05	9.53	40.8	44.2	81.6	85.0	29.3	4.8	39.1	28,000	3,995	8.2
120H-2	inch	1.500	0.875	1.000	0.437	2.01	2.17	4.02	4.18	1.382	0.220	1.925	83,600	12,000	7.75
	mm	38.10	22.23	25.40	11.10	51.0	55.1	102.0	106.1	35.1	5.6	48.9	38,000	5,455	11.6
140H-2	inch	1.750	1.000	1.000	0.500	2.15	2.33	4.31	4.49	1.610	0.250	2.055	108,400	15,730	11.1
	mm	44.45	25.40	25.40	12.70	54.7	59.3	109.4	114.0	40.9	6.4	52.2	49,275	7,150	16.6
160H-2	inch	2.000	1.125	1.250	0.562	2.56	2.76	5.11	5.31	1.839	0.283	2.437	137,600	20,970	14.2
	mm	50.80	28.58	31.75	14.27	64.9	70.0	129.8	134.9	46.7	7.2	61.9	62,545	9,530	21.2
180H-2	inch	2.250	1.406	1.406	0.687	2.84	3.06	5.68	5.90	2.067	0.315	2.700	167,800	22,930	20.8
	mm	57.15	35.71	35.71	17.45	72.1	77.7	144.2	149.8	52.5	8.0	68.6	76,275	10,425	31.1
200H-2	inch	2.500	1.562	1.500	0.781	3.21	3.56	6.43	6.77	2.354	0.374	3.083	233,800	28,550	23.6
	mm	63.50	39.67	38.10	19.84	81.6	90.4	163.2	172.0	59.8	9.5	78.3	106,275	12,975	35.2

Chain Dimensions - Triple Strand

MAXCO Chain Number	Units	Chain Pitch P	Roller			Pin				Side Plate		Trans. Pitch TP	Average Ultimate Strength Lbs Kg-f	Rated Working Load Lbs Kg-f	Average Chain Weight Lbs/ft Kg/m
			Dia R	Inside Width W	Dia D	Length				Height H	Thick. T				
						L1	L2	LR	LC						
60H-3	inch	0.750	0.469	0.500	0.234	1.59	1.69	3.17	3.27	0.689	0.126	1.028	36,900	5,010	3.61
	mm	19.05	11.91	12.70	5.94	40.3	42.8	80.6	83.1	17.5	3.2	26.1	16,775	2,275	5.39
80H-3	inch	1.000	0.625	0.625	0.312	1.99	2.11	3.98	4.09	0.921	0.157	1.283	60,900	8,540	5.54
	mm	25.40	15.88	15.88	7.92	50.5	53.5	101.0	104.0	23.4	4.0	32.6	27,680	3,880	8.26
100H-3	inch	1.250	0.750	0.750	0.375	2.38	2.52	4.76	4.90	1.154	0.188	1.539	92,400	12,920	8.22
	mm	31.75	19.05	19.05	9.53	60.4	64.0	120.8	124.4	29.3	4.8	39.1	42,000	5,875	12.3
120H-3	inch	1.500	0.875	1.000	0.437	2.96	3.12	5.93	6.09	1.382	0.220	1.925	125,400	17,640	11.6
	mm	38.10	22.23	25.40	11.10	75.3	79.3	150.6	154.6	35.1	5.6	48.9	57,000	8,020	17.3
140H-3	inch	1.750	1.000	1.000	0.500	3.19	3.37	6.37	6.55	1.610	0.250	2.055	162,600	23,150	16.6
	mm	44.45	25.40	25.40	12.70	80.9	85.5	161.8	166.4	40.9	6.4	52.2	73,910	10,525	24.8
160H-3	inch	2.000	1.125	1.250	0.562	3.78	3.97	7.55	7.75	1.839	0.283	2.437	206,400	30,800	21.2
	mm	50.80	28.58	31.75	14.27	95.9	100.9	191.8	196.8	46.7	7.2	61.9	93,820	14,000	31.5
180H-3	inch	2.250	1.406	1.406	0.687	4.19	4.42	8.38	8.61	2.067	0.315	2.700	251,700	33,500	30.1
	mm	57.15	35.71	35.71	17.45	106.4	112.3	212.8	218.7	52.5	8.0	68.6	114,410	15,225	44.9
200H-3	inch	2.500	1.562	1.500	0.781	4.75	5.10	9.50	9.85	2.354	0.374	3.083	350,700	41,810	41.9
	mm	63.50	39.67	38.10	19.84	120.7	129.6	241.4	250.3	59.8	9.5	78.3	159,410	19,005	62.5

ASME/ANSI Through Hardened Pin (E) Series Roller Chain

E-Series roller chains possess alloy steel through hardened pins to significantly improve shock load resistance and increase ultimate strength. These chains are often used on heavy construction or mining equipment when superior toughness is required. E-series roller chains operate on standard ASME/ANSI sprockets . . . Hardened teeth are recommended. The suffix "E" is used after the chain number to denote this series.

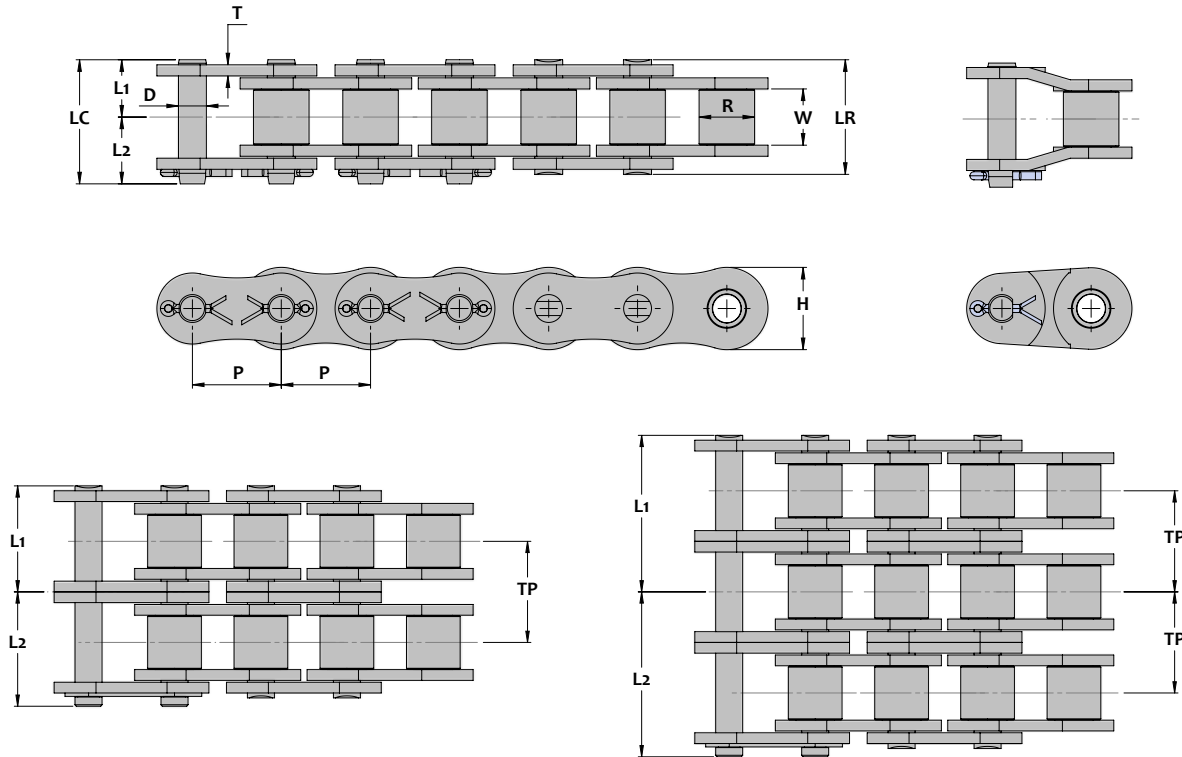

Chain Dimensions - Single Strand

MAXCO Chain Number	Units	Chain Pitch P	Roller			Pin				Side Plate		Average Ultimate Strength Lbs Kg-f	Rated Working Load Lbs Kg-f	Average Chain Weight Lbs/ft Kg/m
			Dia R	Inside Width W	Dia D	Length				Height H	Thick. T			
						L1	L2	LR	LC					
60E	inch	0.750	0.469	0.500	0.234	0.50	0.56	1.01	1.06	0.689	0.094	10,300	2,475	0.98
	mm	19.05	11.91	12.70	5.94	12.8	14.1	25.6	26.9	17.5	2.4	4,680	1,125	1.46
80E	inch	1.000	0.625	0.625	0.312	0.65	0.75	1.29	1.40	0.921	0.126	17,850	4,135	1.69
	mm	25.40	15.88	15.88	7.92	16.4	19.1	32.8	35.5	23.4	3.2	8,115	1,880	2.52
100E	inch	1.250	0.750	0.750	0.375	0.78	0.92	1.55	1.69	1.154	0.157	26,750	6,360	2.62
	mm	31.75	19.05	19.05	9.53	19.7	23.3	39.4	43.0	29.3	4.0	12,160	2,890	3.91
120E	inch	1.500	0.875	1.000	0.437	0.98	1.13	1.95	2.10	1.382	0.188	39,100	8,540	3.86
	mm	38.10	22.23	25.40	11.10	24.8	28.6	49.6	53.4	35.1	4.8	17,775	3,882	5.76
140E	inch	1.750	1.000	1.000	0.500	1.06	1.23	2.13	2.30	1.610	0.220	51,000	11,310	4.97
	mm	44.45	25.40	25.40	12.70	27.0	31.3	54.0	58.3	40.9	5.6	23,180	5,140	7.41
160E	inch	2.000	1.125	1.250	0.562	1.27	1.44	2.54	2.7	1.839	0.250	66,100	14,900	6.56
	mm	50.80	28.58	31.75	14.27	32.2	36.5	64.4	68.7	46.7	6.4	30,045	6,775	9.79
180E	inch	2.250	1.406	1.406	0.687	1.43	1.66	2.86	3.09	2.067	0.283	81,600	15,870	8.98
	mm	57.15	35.71	35.71	17.45	36.3	42.1	72.6	78.4	52.5	7.2	37,090	7,215	13.4
200E	inch	2.500	1.562	1.500	0.781	1.55	1.88	3.09	3.43	2.354	0.315	105,700	18,500	11.4
	mm	63.50	39.67	38.10	19.84	39.3	47.7	78.6	87.0	59.8	8.0	48,045	8,409	16.9

ASME/ANSI Through Hardened Pin (E) Series Roller Chain

Chain Dimensions - Double Strand

MAXCO Chain Number	Units	Chain Pitch P	Roller			Pin				Side Plate		Trans. Pitch TP	Average Ultimate Strength Lbs Kg-f	Rated Working Load Lbs Kg-f	Average Chain Weight Lbs/ft Kg/m
			Dia	Inside Width	Dia	Length				Height	Thick.				
			R	W	D	L1	L2	LR	LC	H	T				
60E-2	inch	0.750	0.469	0.500	0.234	0.94	1.01	1.89	1.96	0.689	0.094	0.898	20,590	4,100	1.98
	mm	19.05	11.91	12.70	5.94	24.0	25.7	48.0	26.9	17.5	2.4	22.8	9,360	1,865	2.95
80E-2	inch	1.000	0.625	0.625	0.312	1.21	1.33	2.43	2.54	0.921	0.126	1.154	35,750	6,000	3.42
	mm	25.40	15.88	15.88	7.92	30.8	33.7	61.6	64.5	23.4	3.2	29.3	15,340	2,725	5.10
100E-2	inch	1.250	0.750	0.750	0.375	1.48	1.62	2.96	3.10	1.154	0.157	1.409	53,500	9,170	5.19
	mm	31.75	19.05	19.05	9.53	37.6	41.2	75.2	78.8	29.3	4.0	35.8	24,320	4,170	7.74
120E-2	inch	1.500	0.875	1.000	0.437	1.87	2.02	3.74	3.89	1.382	0.188	1.787	78,200	12,180	7.70
	mm	38.10	22.23	25.40	11.10	47.5	51.3	95.0	98.8	35.1	4.8	45.4	35,545	5,535	11.5
140E-2	inch	1.750	1.000	1.000	0.500	2.03	2.19	4.06	4.22	1.610	0.22	1.925	102,000	16,460	9.81
	mm	44.45	25.40	25.40	12.70	51.5	55.7	103.0	107.2	40.9	5.6	48.9	46,365	7,480	14.6
160E-2	inch	2.000	1.125	1.250	0.562	2.42	2.59	4.83	5.01	1.839	0.250	2.303	132,200	21,360	13.0
	mm	50.80	28.58	31.75	14.27	61.4	65.8	122.8	127.2	46.7	6.4	58.5	60,090	9,710	19.5
180E-2	inch	2.250	1.406	1.406	0.687	2.72	2.95	5.44	5.67	2.067	0.283	2.591	163,210	22,930	17.9
	mm	57.15	35.71	35.71	17.45	69.1	74.9	138.2	144.0	52.5	7.2	65.8	74,185	10,425	26.6
200E-2	inch	2.500	1.562	1.500	0.781	2.96	3.29	5.91	6.25	2.354	0.315	2.819	211,400	29,230	22.6
	mm	63.50	39.67	38.10	19.84	75.1	83.6	150.2	158.7	59.8	8.0	71.6	96,090	13,285	33.7

Chain Dimensions - Triple Strand

MAXCO Chain Number	Units	Chain Pitch P	Roller			Pin				Side Plate		Trans. Pitch TP	Average Ultimate Strength Lbs Kg-f	Rated Working Load Lbs Kg-f	Average Chain Weight Lbs/ft Kg/m
			Dia.	Inside Width	Dia	Length				Height	Thick.				
			R	W	D	L1	L2	LR	LC	H	T				
60E-3	inch	0.750	0.469	0.500	0.234	1.39	1.47	2.77	2.86	0.689	0.094	0.898	30,800	6,180	2.97
	mm	19.05	11.91	12.70	5.94	35.2	37.4	70.7	72.6	17.5	2.4	22.8	14,000	2,810	4.43
80E-3	inch	1.000	0.625	0.625	0.312	1.79	1.91	3.58	3.70	0.921	0.126	1.154	53,500	8,835	5.15
	mm	25.40	15.88	15.88	7.92	45.5	48.6	91.0	94.1	23.4	3.2	29.3	24,320	4,015	7.68
100E-3	inch	1.250	0.750	0.750	0.375	2.19	2.33	4.37	4.51	1.154	0.157	1.409	80,260	13,490	7.78
	mm	31.75	19.05	19.05	9.53	55.5	59.1	111.0	114.6	29.3	4.0	35.8	36,480	6,130	11.6
120E-3	inch	1.500	0.875	1.000	0.437	2.76	2.91	5.53	5.68	1.382	0.188	1.787	117,300	17,940	11.5
	mm	38.10	22.23	25.40	11.10	70.2	74.0	140.4	144.2	35.1	4.8	45.4	53,320	8,155	17.2
140E-3	inch	1.750	1.000	1.000	0.500	2.99	3.17	5.98	6.15	1.610	0.220	1.925	153,000	24,280	14.7
	mm	44.45	25.40	25.40	12.70	75.9	80.4	151.8	156.3	40.9	5.6	48.9	69,545	11,035	21.9
160E-3	inch	2.000	1.125	1.250	0.562	3.57	3.74	7.14	7.31	1.839	0.250	2.303	198,300	31,470	19.6
	mm	50.80	28.58	31.75	14.27	90.7	95.0	181.4	185.7	46.7	6.4	58.5	90,135	14,305	29.2
180E-3	inch	2.250	1.406	1.406	0.687	4.03	4.25	8.06	8.28	2.067	0.283	2.591	244,820	33,720	26.8
	mm	57.15	35.71	35.71	17.45	102.3	107.9	204.6	210.2	52.5	7.2	65.8	111,280	15,325	39.9
200E-3	inch	2.500	1.562	1.500	0.781	4.37	4.70	8.73	9.06	2.354	0.315	2.819	317,100	42,940	33.9
	mm	63.50	39.67	38.10	19.84	110.9	119.3	221.8	230.2	59.8	8.0	71.6	144,135	19,520	50.5

ASME/ANSI Heavy-Through Hardened Pin (HE) Roller Chain

HE-Series roller chains possess alloy steel through hardened pins and one size thicker link plates for maximum toughness. A combination of the features found in the Heavy (H-Series) and E-Series chains provide reliable performance in the toughest applications. Single strand chains operate over standard ASME/ANSI sprockets (hardened teeth recommended), however multiple strand chains require special sprockets due to their increased transverse pitch. The suffix "HE" is used after the chain number to denote this series.

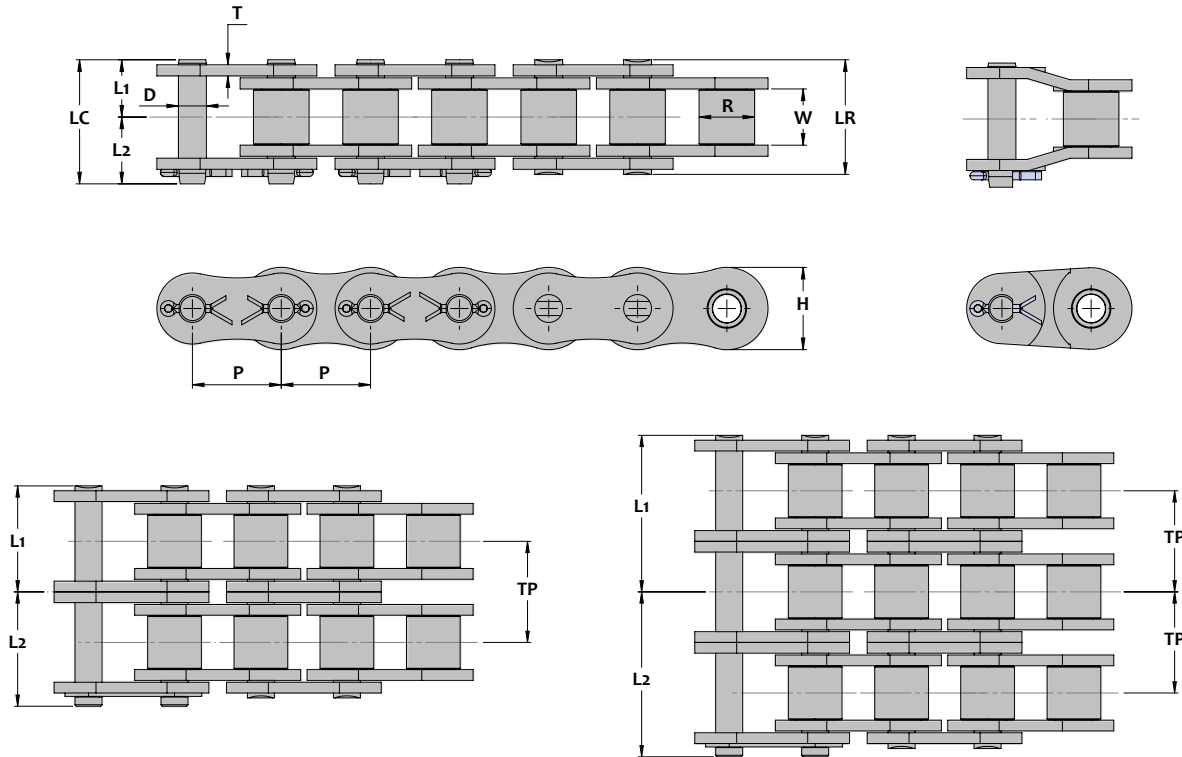

Chain Dimensions - Single Strand

MAXCO Chain Number	Units	Chain Pitch P	Roller			Pin				Side Plate		Average Ultimate Strength Lbs Kg-f	Rated Working Load Lbs Kg-f	Average Chain Weight Lbs/ft Kg/m
			Dia R	Inside Width W	Dia D	Length			Height H	Thick. T				
						L1	L2	LR			LC			
60HE	inch	0.750	0.469	0.500	0.234	0.57	0.65	1.13	1.21	0.689	0.126	12,500	2,475	1.21
	mm	19.05	11.91	12.70	5.94	14.4	16.4	28.8	30.8	17.5	3.2	5,680	1,125	1.80
80HE	inch	1.000	0.625	0.625	0.312	0.70	0.82	1.41	1.52	0.921	0.157	21,000	4,135	1.88
	mm	25.40	15.88	15.88	7.92	17.9	20.8	35.7	38.7	23.4	4.0	9,545	1,880	2.81
100HE	inch	1.250	0.750	0.750	0.375	0.83	0.97	1.67	1.81	1.154	0.188	32,000	6,360	2.78
	mm	31.75	19.05	19.05	9.53	21.2	24.7	42.4	45.9	29.3	4.8	14,545	2,890	4.14
120HE	inch	1.500	0.875	1.000	0.437	1.04	1.21	2.08	2.25	1.382	0.220	43,000	8,540	3.91
	mm	38.10	22.23	25.40	11.10	26.4	30.8	52.8	57.2	35.1	5.6	19,545	3,880	5.83
140HE	inch	1.750	1.000	1.000	0.500	1.13	1.31	2.25	2.43	1.610	0.250	56,600	11,310	5.64
	mm	44.45	25.40	25.40	12.70	28.6	33.2	57.2	61.8	40.9	6.4	25,725	5,140	8.41
160HE	inch	2.000	1.125	1.250	0.562	1.34	1.54	2.68	2.87	1.839	0.283	71,700	14,900	7.28
	mm	50.80	28.58	31.75	14.27	34.0	39.0	67.9	73.0	46.7	7.2	32,590	6,775	10.86
180HE	inch	2.250	1.406	1.406	0.687	1.49	1.72	2.98	3.21	2.067	0.315	99,100	15,870	10.18
	mm	57.15	35.71	35.71	17.45	37.8	43.7	75.6	81.5	52.5	8.0	45,045	7,215	15.18
200HE	inch	2.500	1.562	1.500	0.781	1.67	2.01	3.34	3.68	2.354	0.374	125,600	18,500	11.97
	mm	63.50	39.67	38.10	19.84	42.4	51.0	84.8	93.4	59.8	9.5	57,090	8,410	17.85

ASME/ANSI Heavy-Through Hardened Pin (HE) Series Roller Chain

Chain Dimensions - Double Strand

MAXCO Chain Number	Units	Chain Pitch P	Roller			Pin				Side Plate		Trans. Pitch TP	Average Ultimate Strength Lbs Kg-f	Rated Working Load Lbs Kg-f	Average Chain Weight Lbs/ft Kg/m
			Dia.	Inside Width W	Dia. D	Length				Height H	Thick. T				
			R			L1	L2	LR	LC						
60HE-2	inch	0.750	0.469	0.500	0.234	1.08	1.17	2.16	2.24	0.689	0.126	1.028	25,000	4,115	2.41
	mm	19.05	11.91	12.70	5.94	27.4	29.6	54.8	57.0	17.5	3.2	26.1	11,365	1,870	3.59
80HE-2	inch	1.000	0.625	0.625	0.312	1.35	1.46	2.69	2.81	0.921	0.157	1.283	42,000	6,385	3.71
	mm	25.40	15.88	15.88	7.92	34.2	37.1	68.4	71.3	23.4	4.0	32.6	19,090	2,900	5.54
100HE-2	inch	1.250	0.750	0.750	0.375	1.61	1.74	3.21	3.35	1.154	0.188	1.539	64,000	10,140	5.5
	mm	31.75	19.05	19.05	9.53	40.8	44.2	81.6	85.0	29.3	4.8	39.1	29,090	4,610	8.2
120HE-2	inch	1.500	0.875	1.000	0.437	2.01	2.17	4.02	4.18	1.382	0.220	1.925	86,000	13,110	7.75
	mm	38.10	22.23	25.40	11.10	51.0	55.1	102.0	106.1	35.1	5.6	48.9	39,090	5,960	11.56
140HE-2	inch	1.750	1.000	1.000	0.500	2.15	2.33	4.31	4.49	1.610	0.250	2.055	113,200	17,240	11.12
	mm	44.45	25.40	25.40	12.70	54.7	59.3	109.4	114.0	40.9	6.4	52.2	51,455	7,835	16.59
160HE-2	inch	2.000	1.125	1.250	0.562	2.56	2.76	5.11	5.31	1.839	0.283	2.437	143,400	22,480	14.22
	mm	50.80	28.58	31.75	14.27	64.9	70.0	129.8	134.9	46.7	7.2	61.9	65,180	10,220	21.21
180HE-2	inch	2.250	1.406	1.406	0.687	2.84	3.06	5.68	5.90	2.067	0.315	2.700	198,200	27,200	20.83
	mm	57.15	35.71	35.71	17.45	72.1	77.7	144.2	149.8	52.5	8.0	68.6	90,090	12,365	31.06
200HE-2	inch	2.500	1.562	1.500	0.781	3.21	3.56	6.43	6.77	2.354	0.374	3.083	251,200	31,020	23.60
	mm	63.50	39.67	38.10	19.84	81.6	90.4	163.2	172.0	59.8	9.5	78.3	114,180	14,100	35.20

Chain Dimensions - Triple Strand

MAXCO Chain Number	Units	Chain Pitch P	Roller			Pin				Side Plate		Trans. Pitch TP	Average Ultimate Strength Lbs Kg-f	Rated Working Load Lbs Kg-f	Average Chain Weight Lbs/ft Kg/m
			Dia.	Inside Width W	Dia. D	Length				Height H	Thick. T				
			R			L1	L2	LR	LC						
60HE-3	inch	0.750	0.469	0.500	0.234	1.59	1.69	3.17	3.27	0.689	0.126	1.028	37,500	6,045	3.61
	mm	19.05	11.91	12.70	5.94	40.3	42.8	80.6	83.1	17.5	3.2	26.1	17,045	2,750	5.39
80HE-3	inch	1.000	0.625	0.625	0.312	1.99	2.11	3.98	4.09	0.921	0.157	1.283	63,000	9,400	5.54
	mm	25.40	15.88	15.88	7.92	50.5	53.5	101.0	104.0	23.4	4.0	32.6	28,635	4,275	8.26
100HE-3	inch	1.250	0.750	0.750	0.375	2.38	2.52	4.76	4.90	1.154	0.188	1.539	96,000	14,900	8.22
	mm	31.75	19.05	19.05	9.53	60.4	64.0	120.8	124.4	29.3	4.8	39.1	43,635	6,775	12.26
120HE-3	inch	1.500	0.875	1.000	0.437	2.96	3.12	5.93	6.09	1.382	0.220	1.925	129,000	19,290	11.59
	mm	38.10	22.23	25.40	11.10	75.3	79.3	150.6	154.6	35.1	5.6	48.9	58,635	8,770	17.29
140HE-3	inch	1.750	1.000	1.000	0.500	3.19	3.37	6.37	6.55	1.610	0.250	2.055	169,800	25,400	16.61
	mm	44.45	25.40	25.40	12.70	80.9	85.5	161.8	166.4	40.9	6.4	52.2	77,180	11,545	24.77
160HE-3	inch	2.000	1.125	1.250	0.562	3.78	3.97	7.55	7.75	1.839	0.283	2.437	215,100	33,050	21.15
	mm	50.80	28.58	31.75	14.27	95.9	100.9	191.8	196.8	46.7	7.2	61.9	97,775	15,025	31.54
180HE-3	inch	2.250	1.406	1.406	0.687	4.19	4.42	8.38	8.61	2.067	0.315	2.700	297,300	40,240	30.13
	mm	57.15	35.71	35.71	17.45	106.4	112.3	212.8	218.7	52.5	8.0	68.6	135,135	18,290	44.94
200HE-3	inch	2.500	1.562	1.500	0.781	4.75	5.10	9.50	9.85	2.354	0.374	3.083	376,800	45,860	41.810
	mm	63.50	39.67	38.10	19.84	120.7	129.6	241.4	250.3	59.8	9.5	78.3	171,275	20,845	62.53

ASME/ANSI Super (SU) and Super Heavy (HSU) Roller Chain

Super Series roller chains utilize special alloy steels for pins, rollers and link plates to increase strength and durability. In addition quad staked pins improve fatigue strength and hold the assembly together better when challenged in the most severe conditions. Chains are available in standard (SU) and heavy (HSU) versions. Offset links are not available and connecting links will be press fit style. The suffix "SU" is used for Super Series and "HSU" is used for Super Heavy Series, after the chain number to denote this series.

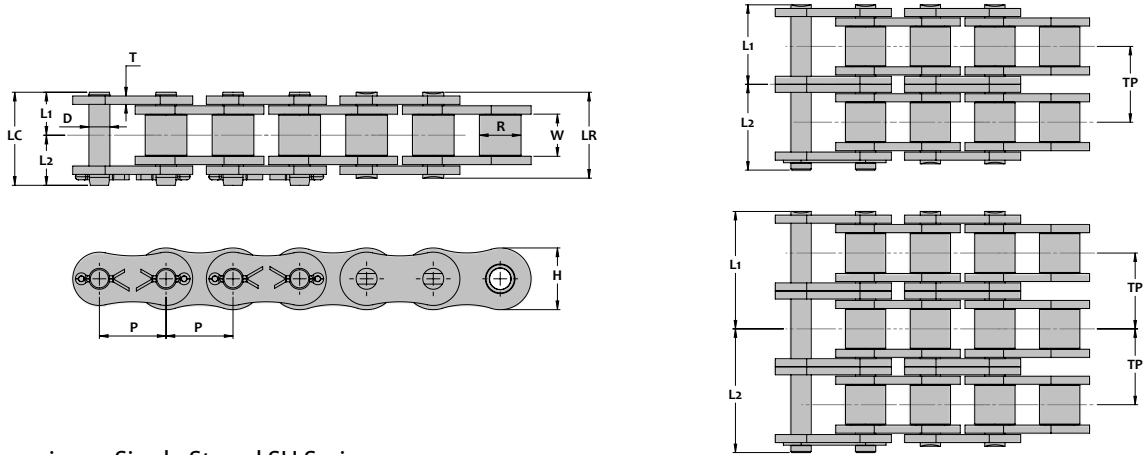

Chain Dimensions - Single Strand SU Series

MAXCO Chain Number	Units	Chain Pitch P	Roller			Pin				Side Plate		Average Ultimate Strength Lbs Kg-f	Rated Working Load Lbs Kg-f	Average Chain Weight Lbs/ft Kg/m
			Dia R	Inside Width W	Dia D	Length				Height H	Thick. T			
						L1	L2	LR	LC					
80SU	inch	1.000	0.625	0.625	0.312	0.65	0.75	1.29	1.40	0.949	0.126	18,950	4,180	1.88
	mm	25.40	15.88	15.88	7.92	16.4	19.1	32.8	35.5	24.1	3.2	8,615	1,900	2.81
100SU	inch	1.250	0.750	0.750	0.375	0.78	0.92	1.55	1.69	1.185	0.157	28,550	6,835	2.86
	mm	31.75	19.05	19.05	9.53	19.7	23.3	39.4	43.0	30.1	4.0	12,975	3,110	4.26
120SU	inch	1.500	0.875	1.000	0.437	0.98	1.13	1.95	2.10	1.425	0.188	41,800	8,815	4.22
	mm	38.10	22.23	25.40	11.10	24.8	28.6	49.6	53.4	36.2	4.8	19,000	4,010	6.30
140SU	inch	1.750	1.000	1.000	0.500	1.06	1.23	2.13	2.30	1.661	0.220	55,100	12,120	5.39
	mm	44.45	25.40	25.40	12.70	27.0	31.3	54.0	58.3	42.2	5.6	25,045	5,510	8.04
160SU	inch	2.000	1.125	1.250	0.562	1.27	1.44	2.54	2.7	1.898	0.250	70,600	15,870	7.24
	mm	50.80	28.58	31.75	14.27	32.2	36.5	64.4	68.7	48.2	6.4	32,090	7,215	10.8
200SU	inch	2.500	1.562	1.500	0.781	1.55	1.88	3.09	3.43	2.374	0.315	110,150	21,150	11.8
	mm	63.50	39.67	38.10	19.84	39.3	47.7	78.6	87.0	60.3	8.0	50,070	9,615	17.6
240SU	inch	3.000	1.875	1.875	0.936	1.90	2.20	3.80	4.10	2.850	0.374	163,200	29,670	17.2
	mm	76.20	47.63	47.63	23.78	48.2	55.9	96.4	104.1	72.4	9.5	74,180	13,485	25.6

Chain Dimensions - Single Strand HSU Series

80HSU	inch	1.000	0.625	0.625	0.312	0.70	0.82	1.41	1.52	0.949	0.157	22,050	4,630	2.23
	mm	25.40	15.88	15.88	7.92	17.9	20.8	35.7	38.7	24.1	4.0	10,025	2,105	3.33
100HSU	inch	1.250	0.750	0.750	0.375	0.83	0.97	1.67	1.81	1.185	0.188	32,600	7,285	3.27
	mm	31.75	19.05	19.05	9.53	21.2	24.7	42.4	45.9	30.1	4.8	14,820	3,310	4.88
120HSU	inch	1.500	0.875	1.000	0.437	1.04	1.21	2.08	2.25	1.425	0.220	44,050	9,485	4.65
	mm	38.10	22.23	25.40	11.10	26.4	30.8	52.8	57.2	36.2	5.6	20,025	4,310	6.94
140HSU	inch	1.750	1.000	1.000	0.500	1.13	1.31	2.25	2.43	1.661	0.250	57,300	12,790	5.95
	mm	44.45	25.40	25.40	12.70	28.6	33.2	57.2	61.8	42.2	6.4	26,045	5,815	8.87
160HSU	inch	2.000	1.125	1.250	0.562	1.34	1.54	2.68	2.87	1.898	0.283	72,800	16,520	7.85
	mm	50.80	28.58	31.75	14.27	34.0	39.0	67.9	73.0	48.2	7.2	33,090	7,510	11.7

ASME/ANSI Super (SU) and Super Heavy (HSU) Series Roller Chain

Chain Dimensions - Double and Triple Strand SU Series

MAXCO Chain Number	Units	Chain Pitch P	Roller		Pin				Side Plate		Trans. Pitch TP	Average Ultimate Strength Lbs Kg-f	Rated Working Load Lbs Kg-f	Average Chain Weight Lbs/ft Kg/m	
			Dia	Inside Width W	Dia D	Length				Height H					Thick. T
			R		L1	L2	LR	LC							
80-2SU	inch	1.000	0.625	0.625	0.312	1.21	1.33	2.43	2.54	0.949	0.126	1.154	37,990	7,105	3.78
	mm	25.40	15.88	15.88	7.92	30.8	33.7	61.6	64.5	24.1	3.2	29.3	17,270	3,230	5.63
80-3SU	inch					1.79	1.91	3.58	3.70				56,850	10,450	5.64
	mm					45.5	48.6	90.9	94.1				25,840	4,750	8.41
100-2SU	inch	1.250	0.750	0.750	0.375	1.48	1.62	2.96	3.10	1.185	0.157	1.409	57,100	11,620	5.62
	mm	31.75	19.05	19.05	9.53	37.6	41.2	75.2	78.8	30.1	4.0	35.8	25,955	5,280	8.38
100-3SU	inch					2.19	2.33	4.37	4.51				85,650	17,080	8.43
	mm					55.5	59.1	110.9	114.6				38,930	7,765	12.6
120-2SU	inch	1.500	0.875	1.000	0.437	1.87	2.02	3.74	3.89	1.425	0.188	1.787	83,600	14,970	8.34
	mm	38.10	22.23	25.40	11.10	47.5	51.3	95.0	98.8	36.2	4.8	45.4	38,000	6,805	12.4
120-3SU	inch					2.76	2.91	5.52	5.68				125,400	22,030	12.5
	mm					70.2	74.0	140.3	144.2				57,000	10,015	18.7
140-2SU	inch	1.750	1.000	1.000	0.500	2.03	2.19	4.06	4.22	1.661	0.220	1.925	110,200	20,590	10.7
	mm	44.45	25.40	25.40	12.70	51.5	55.7	103.0	107.2	42.2	5.6	48.9	50,090	9,360	15.9
140-3SU	inch					2.99	3.17	5.97	6.15				165,300	30,350	16.0
	mm					75.9	80.4	151.7	156.3				75,135	13,795	23.8
160-2SU	inch	2.000	1.125	1.250	0.562	2.42	2.59	4.83	5.01	1.898	0.250	2.303	141,200	26,980	14.4
	mm	50.80	28.58	31.75	14.27	61.4	65.8	122.8	127.2	48.2	6.4	58.5	64,180	12,265	21.4
160-3SU	inch					3.57	3.74	7.14	7.31				211,800	39,790	21.5
	mm					120.2	124.5	240.3	244.7				96,275	18,085	32.1
200-2SU	inch	2.500	1.562	1.500	0.781	2.96	3.29	5.91	6.25	2.374	0.315	2.819	220,300	35,970	23.4
	mm	63.50	39.67	38.10	19.84	75.1	83.6	150.2	158.7	60.3	8.0	71.6	100,135	16,350	34.9
240-2SU	inch	3.000	1.875	1.875	0.936	3.63	3.93	7.25	7.55	2.850	0.374	3.457	326,400	50,360	34.1
	mm	76.20	47.63	47.63	23.78	92.1	99.7	184.2	191.8	72.4	9.5	87.8	148,365	22,890	50.9

Chain Dimensions - Double Strand HSU Series

80H-2SU	inch	1.000	0.625	0.625	0.312	1.35	1.46	2.69	2.81	0.949	0.157	1.283	44,100	7,870	4.47
	mm	25.40	15.88	15.88	7.92	34.2	37.1	68.4	71.3	24.1	4.0	32.6	20,045	3,575	6.67
100H-2SU	inch	1.250	0.750	0.750	0.375	1.61	1.74	3.21	3.35	1.185	0.188	1.539	65,200	12,390	6.44
	mm	31.75	19.05	19.05	9.53	40.8	44.2	81.6	85.0	30.1	4.8	39.1	29,635	5,630	9.60
120H-2SU	inch	1.500	0.875	1.000	0.437	2.01	2.17	4.02	4.18	1.425	0.220	1.925	88,100	16,120	9.19
	mm	38.10	22.23	25.40	11.10	51.0	55.1	102.0	106.1	36.2	5.6	48.9	40,045	7,325	13.7
140H-2SU	inch	1.750	1.000	1.000	0.500	2.15	2.33	4.31	4.49	1.661	0.250	2.055	114,600	21,740	11.8
	mm	44.45	25.40	25.40	12.70	54.7	59.3	109.4	114.0	42.2	6.4	52.2	52,090	9,880	17.6
160H-2SU	inch	2.000	1.125	1.250	0.562	2.56	2.76	5.11	5.31	1.898	0.283	2.437	145,600	28,080	15.5
	mm	50.80	28.58	31.75	14.27	64.9	70.0	129.8	134.9	48.2	7.2	61.9	66,180	12,765	23.2

Double Capacity Roller Chain

Double Capacity roller chains possess twice the number of link plates as single strand roller chain and therefore have twice the ultimate strength. These combination roller/leaf chains are best used on high load hoist, pull down or other tension linkage applications. They may also be used on slow speed drives where link plate breakage or pin shear is an ongoing problem. Double Capacity roller chains operate on standard ASME/ANSI or ISO 606B British Standard sprockets with hardened teeth. Offset Links are not available for this series.

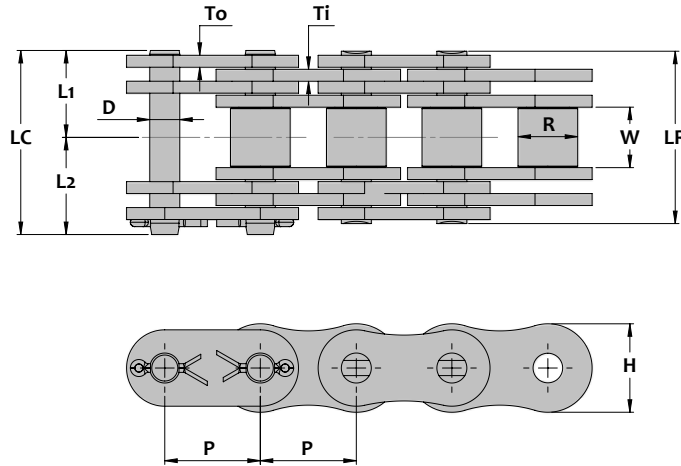

Chain Dimensions - ASME ANSI Standard

MAXCO Chain Number	Units	Chain Pitch P	Roller		Pin					Side Plate		Average Ultimate Strength Lbs Kg-f	Rated Working Load Lbs Kg-f	Average Chain Weight Lbs/ft Kg/m
			Inside Width W	Dia R	Dia D	Length				Height H	Thickness			
						L1	L2	LR	LC	To	Ti			
80DC	inch	1.000	0.625	0.625	0.312	0.90	1.02	1.80	1.92	0.921	0.125	35,300	5,035	2.92
	mm	25.40	15.88	15.88	7.92	22.8	25.9	45.6	48.7	23.4	3.2	16,045	2,290	4.36
100DC	inch	1.250	0.750	0.750	0.375	1.10	1.24	2.20	2.34	1.154	0.157	52,830	7,530	4.35
	mm	31.75	19.05	19.05	9.53	27.9	31.6	55.8	59.5	29.3	4.0	24,015	3,425	6.48
120DC	inch	1.500	1.000	0.875	0.437	1.36	1.53	2.72	2.89	1.382	0.188	77,110	11,020	6.35
	mm	38.10	25.40	22.23	11.10	34.5	38.8	69.0	73.3	35.1	4.8	35,050	5,010	9.47
140DC	inch	1.750	1.000	1.000	0.500	1.50	1.69	3.01	3.19	1.610	0.220	101,390	14,480	8.29
	mm	44.45	25.40	25.40	12.70	38.2	42.9	76.4	81.1	40.9	5.6	46,085	6,580	12.4
160DC	inch	2.000	1.250	1.125	0.562	1.77	1.97	3.54	3.74	1.839	0.250	125,670	17,940	11.2
	mm	50.80	31.75	28.58	14.27	45.0	50.1	90.0	95.1	46.7	6.4	57,125	8,155	16.7
180DC	inch	2.250	1.406	1.406	0.687	2.00	2.24	4.00	4.24	2.067	0.283	163,210	23,150	14.4
	mm	57.15	35.7	35.7	17.45	50.8	56.9	101.6	107.7	52.5	7.2	74,185	10,525	21.5
200DC	inch	2.500	1.500	1.562	0.781	2.19	2.54	4.38	4.72	2.354	0.315	209,520	29,900	18.8
	mm	63.50	38.10	39.67	19.84	55.6	64.4	111.2	120.0	59.8	8.0	95,235	13,590	28.0
240DC	inch	3.000	1.875	1.875	0.936	2.67	2.97	5.34	5.64	2.768	0.374	304,170	43,390	27.2
	mm	76.20	47.63	47.63	23.78	67.8	75.4	135.6	143.2	70.3	9.5	138,260	19,725	40.6

Chain Dimensions - British Standard

16BDC	inch	1.000	0.673	0.625	0.312	0.98	1.11	1.97	2.09	0.921	0.157	0.125	30,800	4,385	2.99
	mm	25.40	17.1	15.88	7.93	25.0	28.2	50.0	53.2	23.4	4.0	3.2	14,000	1,995	4.46
20BDC	inch	1.250	0.772	0.750	0.375	1.10	1.28	2.20	2.38	1.154	0.177	0.138	47,660	6,790	4.28
	mm	31.75	19.6	19.05	9.53	28.0	32.4	56.0	60.4	29.3	4.5	3.5	21,665	3,085	6.38
24BDC	inch	1.500	1.000	1.000	0.437	1.48	1.69	2.97	3.17	1.382	0.232	0.193	80,700	11,510	7.30
	mm	38.10	25.4	25.40	11.10	37.7	42.8	75.4	80.5	35.1	5.9	4.9	36,680	5,230	10.9
28BDC	inch	1.750	1.220	1.100	0.500	1.83	2.06	3.66	3.89	1.610	0.291	0.248	100,490	14,340	9.94
	mm	44.45	31.0	27.94	12.70	46.5	52.3	93.0	98.8	40.9	7.4	6.3	45,675	6,520	14.8
32BDC	inch	2.000	1.244	1.125	0.562	1.82	2.06	3.64	3.88	1.839	0.272	0.248	123,420	17,625	10.4
	mm	50.80	31.6	28.58	14.28	46.2	52.3	92.4	98.5	46.7	6.9	6.3	56,100	8,010	15.5

ASME/ANSI Triple and Quad Capacity Roller Chain

Triple and Quad Capacity roller chains possess three and four times respectively the number of link plates as single strand roller chain and therefore have significantly greater ultimate strength. These combination roller/leaf chains are best used on high load hoist, pull down or other tension linkage applications. Triple and Quad Capacity roller chains operate on special sprockets with hardened teeth. Offset links are not available for this series.

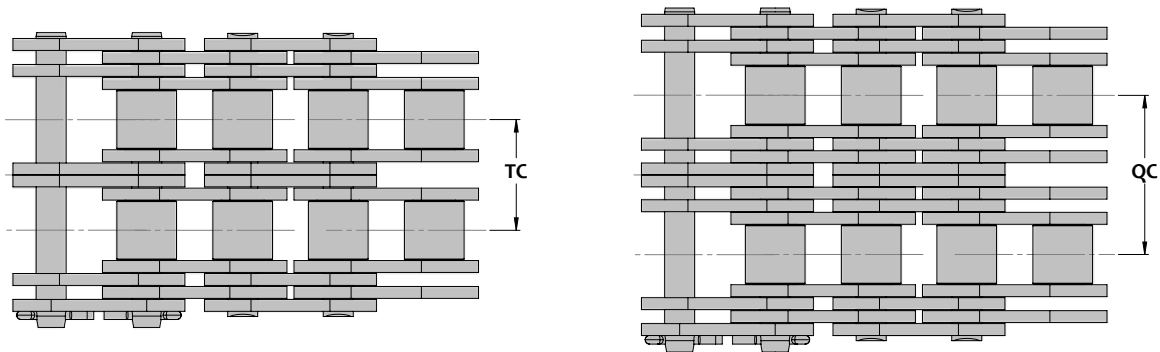

Chain Dimensions - ASME ANSI Standard

MAXCO Chain Number	Units	Chain Pitch P	Roller		Pin Dia D	Side Plate			Transverse Pitch		Average Ultimate Strength	
			Inside Width W	Dia R		Height H	Thickness		TC	QC	Triple Capacity Lbs Kg-f	Quad Capacity Lbs Kg-f
							To	Ti				
80-TC-QC	inch	1.000	0.625	0.625	0.312	0.921	0.125	1.154	1.657	52,830	70,590	
	mm	25.40	15.88	15.88	7.92	23.4	3.2	29.3	42.1	24,015	32,085	
100-TC-QC	inch	1.250	0.750	0.750	0.375	1.154	0.157	1.409	2.039	79,130	105,660	
	mm	31.75	19.05	19.05	9.53	29.3	4.0	35.8	51.8	35,970	48,025	
120-TC-QC	inch	1.500	1.000	0.875	0.437	1.382	0.188	1.787	2.528	115,550	154,220	
	mm	38.10	25.40	22.23	11.10	35.1	4.8	45.4	64.2	52,525	70,100	
140-TC-QC	inch	1.750	1.000	1.000	0.500	1.610	0.220	1.925	2.807	151,970	202,780	
	mm	44.45	25.40	25.40	12.70	40.9	5.6	48.9	71.3	69,075	92,775	
160-TC-QC	inch	2.000	1.250	1.125	0.562	1.839	0.250	2.303	3.311	188,390	251,340	
	mm	50.80	31.75	28.58	14.27	46.7	6.4	58.5	84.1	85,630	114,245	
180-TC-QC	inch	2.250	1.406	1.406	0.687	2.067	0.283	2.591	3.724	244,820	326,420	
	mm	57.15	35.7	35.7	17.45	52.5	7.2	65.8	94.6	111,280	148,375	
200-TC-QC	inch	2.500	1.500	1.562	0.781	2.354	0.315	2.819	4.079	314,280	419,040	
	mm	63.50	38.10	39.67	19.84	59.8	8.0	71.6	103.6	142,855	190,475	
240-TC-QC	inch	3.000	1.875	1.875	0.936	2.768	0.374	3.457	4.953	456,140	608,330	
	mm	76.20	47.63	47.63	23.78	70.3	9.5	87.8	125.8	207,335	276,515	

Chain Dimensions - British Standard

16B-TC-QC	inch	1.000	0.673	0.625	0.312	0.921	0.157	0.125	1.256	1.760	46,090	61,600
	mm	25.40	17.1	15.88	7.93	23.4	4.0	3.2	31.9	44.7	20,950	28,000
20B-TC-QC	inch	1.250	0.772	0.750	0.375	1.154	0.177	0.138	1.437	1.988	71,490	95,320
	mm	31.75	19.6	19.05	9.53	29.3	4.5	3.5	36.5	50.5	32,495	43,325
24B-TC-QC	inch	1.500	1.000	1.000	0.437	1.382	0.232	0.193	1.906	2.677	120,950	161,410
	mm	38.10	25.4	25.40	11.10	35.1	5.9	4.9	48.4	68.0	54,825	73,370
28B-TC-QC	inch	1.750	1.220	1.100	0.500	1.610	0.291	0.248	2.346	3.339	150,620	200,980
	mm	44.45	31.0	27.94	12.70	40.9	7.4	6.3	59.6	84.8	68,465	91,220
32B-TC-QC	inch	2.000	1.244	1.125	0.562	1.839	0.272	0.248	2.307	3.299	185,020	246,840
	mm	50.80	31.6	28.58	14.28	46.7	6.9	6.3	58.6	83.8	84,100	112,200

ASME/ANSI Double Pitch Double Capacity Roller Chain

Double Capacity roller chains possess twice the number of link plates as single strand roller chain and therefore have twice the ultimate strength. These combination roller/leaf chains are best used on high load hoist, pull down or other tension linkage applications. They may also be used on slow speed drives where link plate breakage or pin shear is an ongoing problem. Double Capacity roller chains operate on standard ASME/ANSI sprockets with hardened teeth. Offset Links are not available for this series.

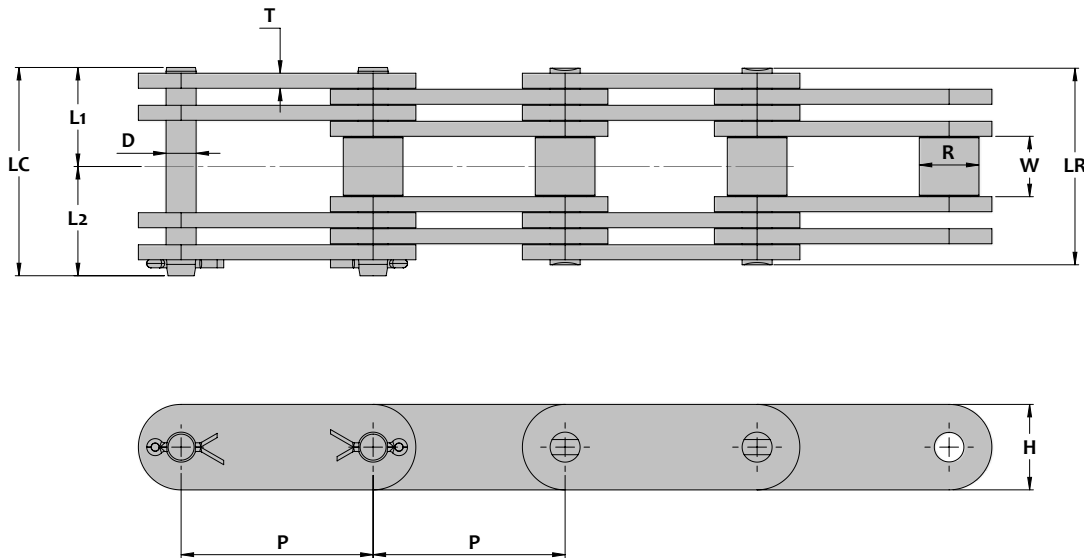

Chain Dimensions

MAXCO Chain Number	Units	Chain Pitch P	Roller			Pin				Side Plate		Average Ultimate Strength Lbs Kg-f	Rated Working Load Lbs Kg-f	Average Chain Weight Lbs/ft Kg/m
			Inside Width W	Dia. R	Dia. D	Length				Height H	Thickness T			
						L1	L2	LR	LC					
C2040DC	inch	1.000	0.312	0.313	0.156	0.45	0.52	0.91	0.97	0.449	0.060	8,590	905	0.34
	mm	25.40	7.92	7.95	3.96	11.5	13.2	23.0	24.7	11.4	1.5	3,905	411	0.50
C2050DC	inch	1.250	0.400	0.375	0.200	0.57	0.63	1.13	1.20	0.591	0.080	14,340	1,510	0.57
	mm	31.75	10.16	9.53	5.08	14.4	16.1	28.8	30.5	15.0	2.0	8,520	686	0.85
C2060HDC	inch	1.500	0.469	0.500	0.234	0.83	0.91	1.66	1.74	0.669	0.126	24,680	2,600	0.98
	mm	38.10	11.91	12.70	5.95	21.1	23.1	42.2	44.2	17.0	3.2	11,220	1,180	1.46
C2080HDC	inch	2.000	0.625	0.625	0.312	1.02	1.15	2.05	2.17	0.890	0.157	40,560	4,270	1.68
	mm	50.80	15.88	15.88	7.93	26.0	29.1	52.0	55.1	22.6	4.0	18,435	1,940	2.50
C2100HDC	inch	2.500	0.750	0.750	0.375	1.22	1.36	2.44	2.58	1.126	0.189	61,600	6,485	2.55
	mm	63.50	19.05	19.05	9.53	31.0	34.6	62.0	65.6	28.6	4.8	28,000	2,950	3.81
C2120HDC	inch	3.000	1.000	0.875	0.437	1.53	1.7	3.06	3.23	1.374	0.220	83,630	8,805	3.69
	mm	76.20	25.40	22.23	11.10	38.9	43.2	77.8	82.1	34.9	5.6	38,015	4,000	5.50
C2160HDC	inch	4.000	1.125	1.250	0.562	1.92	2.12	3.83	4.04	1.874	0.283	137,580	14,480	6.22
	mm	101.60	28.58	31.75	14.28	48.7	53.9	97.4	102.6	47.6	7.2	62,535	6,580	9.27

ASME/ANSI Rollerless Hoist Chain

ASME/ANSI Rollerless Hoist Chains are designed for high load tension linkage applications such as hoists, lifts or reciprocating motion equipment. Chain pins are through hardened and quad stacked for additional strength and holding power. Offset links are not available for these chains. The chain numbers are the same as ASME/ANSI standard Roller Chains except that the last digit is changed to a "5" instead of a "0".

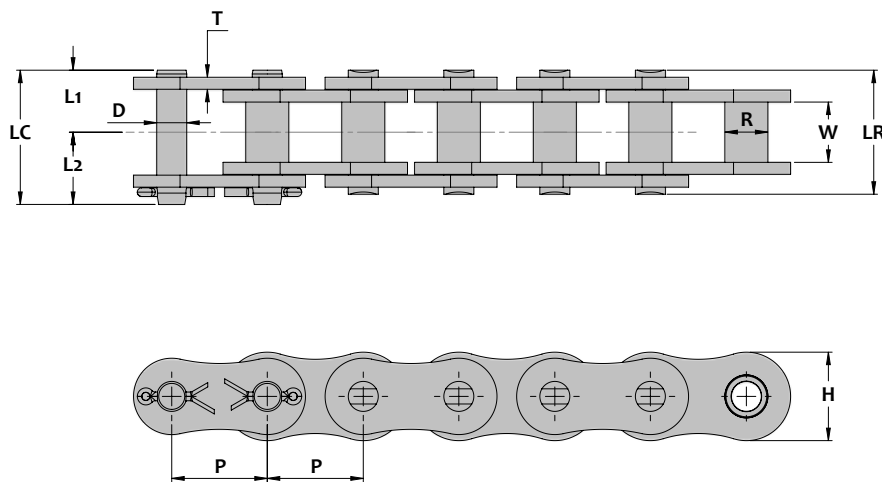

Chain Dimensions

MAXCO Chain Number	Units	Chain Pitch P	Bushing			Pin				Side Plate		Average Ultimate Strength Lbs Kg-f	Rated Working Load Lbs Kg-f	Average Chain Weight Lbs/ft Kg/m
			Dia. R	Inside Width W	Dia D	Length				Height H	Thick. T			
						L1	L2	LR	LC					
65	inch	0.750	0.330	0.500	0.234	0.50	0.56	1.01	1.06	0.689	0.094	10,300	2,475	0.81
	mm	19.05	8.38	12.70	5.94	12.8	14.1	25.6	26.9	17.5	2.4	4,680	1,125	1.21
85	inch	1.000	0.448	0.625	0.312	0.65	0.75	1.29	1.40	0.921	0.126	17,850	4,135	1.41
	mm	25.40	11.38	15.88	7.92	16.4	19.1	32.8	35.5	23.4	3.2	8,115	1,880	2.10
105	inch	1.250	0.533	0.750	0.375	0.78	0.92	1.55	1.69	1.154	0.157	26,750	6,360	2.08
	mm	31.75	13.54	19.05	9.53	19.7	23.3	39.4	43.0	29.3	4.0	12,160	2,890	3.10
125	inch	1.500	0.627	1.000	0.437	0.98	1.13	1.95	2.10	1.382	0.188	39,110	8,540	3.04
	mm	38.10	15.92	25.40	11.10	24.8	28.6	49.6	53.4	35.1	4.8	17,775	3,880	4.53

Side Bow (Curved) Roller Chain

Side Bow (Curved) roller chains are designed with extra clearance between pins, bushings and link plates to allow operation around a curved path and/or a required twist.

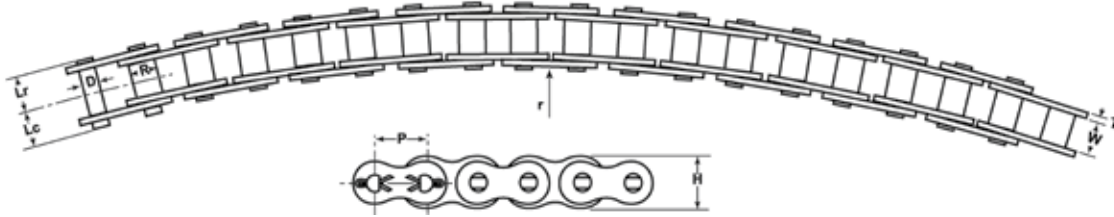

Chain Dimensions - ASME/ANSI Standard

MAXCO Chain Number	Units	Chain Pitch P	Bushing		Pin			Side Plate		Minimum Curve Radius r	Average Ultimate Strength lbs kN	Rated Working Load lbs kN	Average Chain Weight lbs/ft kg/m
			Dia.	Inside Width	Dia	Length		Height	Thick.				
			R	W	D	Lr	Lc	H	T				
40SB	inch	0.500	0.312	0.313	0.141	0.33	0.41	0.461	0.060	13.78	3,350	400	0.42
	mm	12.70	7.92	7.95	3.58	8.5	10.4	11.7	1.5	350	14.9	1.77	0.63
50SB	inch	0.625	0.400	0.375	0.175	0.42	0.49	0.575	0.080	15.75	4,970	705	0.69
	mm	15.875	10.16	9.53	4.45	10.6	12.5	14.6	2.0	400	22.1	3.14	1.03
60SB	inch	0.750	0.469	0.500	0.200	0.52	0.59	0.689	0.094	19.69	6,610	950	0.98
	mm	19.05	11.91	12.70	5.08	13.2	14.9	17.5	2.4	500	29.4	4.22	1.46
80SB	inch	1.000	0.625	0.625	0.281	0.66	0.78	0.921	0.126	23.62	13,020	1,720	1.62
	mm	25.40	15.88	15.88	7.13	16.7	19.7	23.4	3.2	600	57.9	7.65	2.42

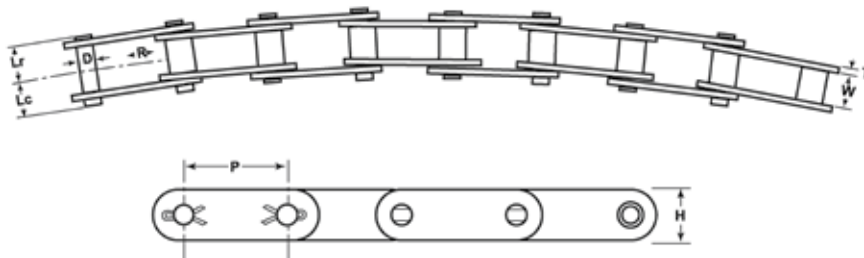

Chain Dimensions - ASME/ANSI Double Pitch

MAXCO Chain Number	Units	Chain Pitch P	Bushing		Pin			Side Plate		Minimum Curve Radius r	Average Ultimate Strength Lbs Kg-f	Rated Working Load Lbs Kg-f	Average Chain Weight Lbs/ft Kg/m
			Dia.	Inside Width	Dia	Length		Height	Thick.				
			R	W	D	Lr	Lc	H	T				
C2040SB	inch	1.00	0.312	0.313	0.141	0.33	0.41	0.449	0.060	27.56	3,350	400	0.32
	mm	25.40	7.92	7.95	3.58	8.5	10.4	11.4	1.5	700	1,525	182	0.48
C2042SB	inch		0.625										0.55
	mm		15.88										0.82
C2050SB	inch	1.25	0.400	0.375	0.175	0.42	0.49	0.591	0.080	31.50	4,970	705	0.55
	mm	31.75	10.16	9.53	4.45	10.6	12.5	15.0	2.0	800	2,260	320	0.82
C2052SB	inch		0.750										0.84
	mm		19.05										1.26
C2060SB	inch	1.500	0.469	0.500	0.200	0.52	0.59	0.669	0.094	39.37	6,610	950	0.80
	mm	38.10	11.91	12.70	5.08	13.2	14.9	17.0	2.4	1,000	3,005	432	1.20
C2062SB	inch		0.875										1.35
	mm		22.23										2.01

Corrosion and Temperature Resistant Roller Chain

General Information

We offer a variety of corrosion and/or temperature resistant roller chain products to suit the particular needs of almost any application. These range from plated or coated carbon steels to a number of different stainless steel types that may be selected based on the desired combination of wear resistance, strength, corrosion resistance and resistance to extremes in operating temperatures.

Nickel Plating

Suitable for mild corrosive conditions such as outdoor service. Often used for decorative purposes. Chain components are plated prior to assembly for uniform coverage of internal components.

Perfect Coat Plus®

A unique dual coating consisting of a mechanically applied zinc alloy and a chemical sealer that provides up to 30 times more resistance to rust compared with conventional nickel plating in salt water testing. The coating is extremely durable and will not chip flake or peel during chain assembly. Excellent for usage on conveyors that have wash down stations and subject the chains to mild detergents or soaps.

Type 304 Stainless

Our standard stainless steel product offers excellent resistance to corrosion and operates successfully over a wide range of temperatures. This material is slightly magnetic due to the work hardening of the components during the manufacturing processes.

Type 316 Stainless

This material possess greater corrosion and temperature resistance compared with Type 304SS. It is often used in the food processing industry due to its resistance to stress corrosion cracking in the presence of chlorides such as are found in liquid smoke. The magnetic permeability of this material is extremely low and is often considered nonmagnetic however it is not considered to be spark proof.

600 Series Stainless

Pins, bushings and rollers are made from 17-7PH stainless steels which can be hardened for improved resistance to wear elongation. The corrosion resistance of this chain is similar to Type 304SS. The operating temperature range of this material however is not as great as Type 304SS.

Mega Chain:

A high strength 304 stainless steel chain. Available in two versions which use different mechanical configurations to obtain additional strength. Both versions offer higher working loads due to a greater pin/bushing bearing area and a unique labyrinth type seal that helps prevent the penetration of abrasive foreign materials to the internal wearing components.

General Properties of Corrosion Resistant Roller Chain Products

Chain	Corrosion Resistance	Temperature Resistance	Wear Resistance	Strength	Magnetism
Nickel Plate	Fair	14°F - 150°F -10°C - 65°C	Excellent	Excellent	Magnetic
Perfect Coat Plus®	Good	14°F - 150°F -10°C - 65°C	Excellent	Excellent	Magnetic
304 Stainless	Very Good	-250°F - 750°F -155°C - 400°C	Fair	Fair	Slightly Magnetic
316 Stainless	Excellent	-250°F - 950°F -155°C - 510°C	Fair	Fair	Non-magnetic
600 Stainless	Very Good	-50°F - 750°F -45°C - 400°C	Very Good	Fair	Slightly Magnetic
Mega Chain	Very Good	-250°F - 750°F -155°C - 400°C	Very Good	Excellent	Slightly Magnetic

ASME/ANSI Standard Nickel Plated Roller Chain

Nickel Plated roller chains generally provide good performance in mild corrosive applications such as general outdoor service. Lubrication is necessary to prevent rust for long periods of time in most cases. Parts are plated prior to heat treatment to assure maximum corrosion protection to the internal components of the chain. This plating provides a bright shiny finish which is sometimes applied for aesthetic reasons

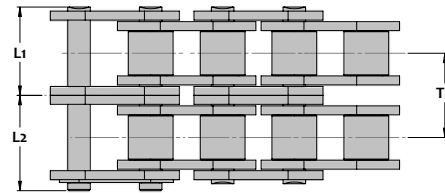
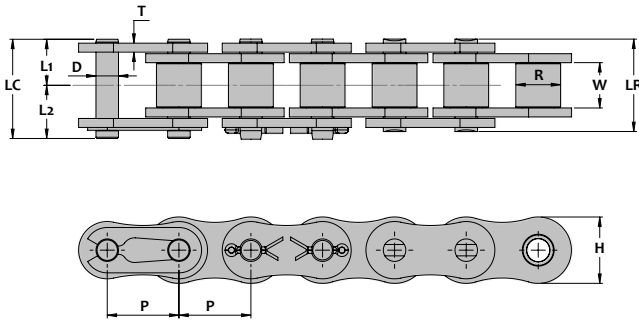

Chain Dimensions - Single Strand

MAXCO Chain Number	Units	Chain Pitch P	Roller			Pin				Side Plate		Trans. Pitch TP	Average Ultimate Strength Lbs Kg-f	Rated Working Load Lbs Kg-f	Average Chain Weight Lbs/ft Kg/m
			Dia.	Inside Width	Dia	Length				Height	Thick.				
			R	W	D	L1	L2	LR	LC	H	T				
25NP	inch	0.250	0.130	0.125	0.091	0.15	0.19	0.30	0.34	0.230	0.030	-	1,050	140	0.10
	mm	6.35	3.20	3.18	2.31	3.8	4.8	7.6	8.6	5.84	0.76	-	475	64	0.15
35NP	inch	0.375	0.200	0.188	0.141	0.24	0.27	0.47	0.51	0.354	0.050	-	2,430	420	0.23
	mm	9.525	5.08	4.78	3.58	6.0	6.9	12.0	12.9	9.0	1.25	-	1,105	191	0.34
41NP	inch	0.500	0.306	0.250	0.141	0.26	0.31	0.52	0.57	0.382	0.050	-	2,600	500	0.30
	mm	12.70	7.77	6.35	3.58	6.6	7.9	13.2	14.5	9.7	1.25	-	1,180	227	0.45
40NP	inch	0.500	0.312	0.313	0.156	0.33	0.38	0.65	0.70	0.461	0.060	-	4,300	685	0.40
	mm	12.70	7.92	7.95	3.96	8.3	9.6	16.6	17.9	11.7	1.5	-	1,955	311	0.60
50NP	inch	0.625	0.400	0.375	0.200	0.40	0.46	0.80	0.87	0.575	0.080	-	7,200	1,210	0.66
	mm	15.875	10.16	9.53	5.08	10.2	11.8	20.4	22.0	14.6	2.0	-	3,275	550	0.98
60NP	inch	0.750	0.469	0.500	0.234	0.50	0.56	1.00	1.06	0.689	0.094	-	10,000	1,630	0.98
	mm	19.05	11.91	12.70	5.95	12.8	14.1	25.5	26.9	17.5	2.4	-	4,545	741	1.46
80NP	inch	1.000	0.625	0.625	0.312	0.65	0.75	1.29	1.40	0.921	0.126	-	17,650	2,850	1.69
	mm	25.4	15.88	15.88	7.93	16.4	19.1	32.8	35.5	23.4	3.2	-	8,025	1,295	2.52
100NP	inch	1.250	0.75	0.750	0.375	0.78	0.92	1.55	1.69	1.154	0.157	-	26,500	4,290	2.62
	mm	31.75	19.05	19.05	9.53	19.7	23.3	39.4	43.0	29.3	4.0	-	12,045	1,950	3.91

Chain Dimensions - Double Strand

35-2NP	inch	0.375	0.200	0.188	0.141	0.44	0.47	0.87	0.91	0.354	0.050	0.398	4,860	710	1.09
	mm	9.525	5.08	4.78	3.58	11.1	11.9	22.2	23.0	9.0	1.25	10.1	2,210	323	1.63
40-2NP	inch	0.500	0.312	0.313	0.156	0.61	0.66	1.21	1.27	0.461	0.060	0.567	8,600	1,160	1.22
	mm	12.70	7.92	7.95	3.96	15.4	16.8	30.8	32.2	11.7	1.5	14.4	3,910	527	1.22
50-2NP	inch	0.625	0.400	0.375	0.200	0.76	0.82	1.51	1.57	0.575	0.080	0.712	14,400	2,040	2.95
	mm	15.875	10.16	9.53	5.08	19.2	20.8	38.4	40.0	14.6	2.0	18.08	6,545	927	2.00
60-2NP	inch	0.750	0.469	0.500	0.234	0.94	1.01	1.90	1.96	0.689	0.094	0.898	19,800	2,765	1.98
	mm	19.05	11.91	12.70	5.95	24.0	25.7	48.2	49.7	17.5	2.4	22.8	9,000	1,255	2.95
80-2NP	inch	1.000	0.625	0.625	0.312	1.21	1.33	2.43	2.54	0.921	0.126	1.154	35,300	4,855	3.42
	mm	25.4	15.88	15.88	7.93	30.8	33.7	61.6	64.5	23.4	3.2	29.3	16,045	2,205	5.10

ISO 606B British Standard Nickel Plated Roller Chain

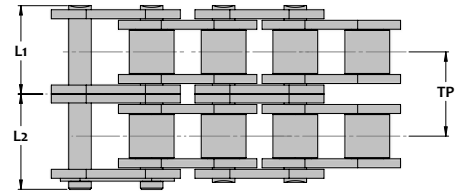
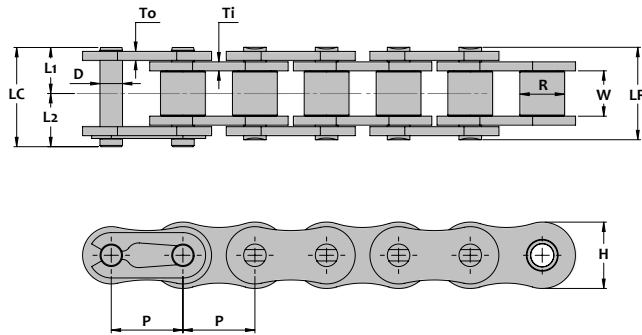

Chain Dimensions - Single Strand

MAXCO Chain Number	Units	Chain Pitch P	Roller			Pin				Side Plate			Trans. Pitch TP	Average Ultimate Strength Lbs Kg-f	Rated Working Load Lbs Kg-f	Average Chain Weight Lbs/ft Kg/m
			Inside Width W	Dia. R	Dia. D	Length				Height H	Thickness					
						L1	L2	LR	LC	To	Ti					
06BNP	inch	0.375	0.225	0.250	0.130	0.25	0.28	0.50	0.53	0.323	0.040	0.050	-	2,200	400	0.29
	mm	9.525	5.72	6.35	3.28	6.3	7.1	12.6	13.4	8.2	1.0	1.25	-	1,000	182	0.43
08BNP	inch	0.500	0.305	0.335	0.175	0.33	0.39	0.66	0.72	0.465	0.060		-	4,400	705	0.41
	mm	12.70	7.75	8.51	4.45	8.4	9.8	16.7	18.2	11.8	1.5		-	2,000	320	0.61
10BNP	inch	0.625	0.380	0.400	0.200	0.37	0.44	0.75	0.81	0.579	0.065		-	5,600	1,100	0.60
	mm	15.875	9.65	10.16	5.08	9.5	11.2	19.0	20.7	14.7	1.65		-	2,545	500	0.89
12BNP	inch	0.750	0.460	0.475	0.225	0.43	0.50	0.87	0.93	0.634	0.070		-	7,190	1,585	0.76
	mm	19.05	11.68	12.07	5.7	11.0	12.6	22.0	23.6	16.1	1.8		-	3,270	720	1.14
16BNP	inch	1.000	0.670	0.625	0.325	0.69	0.81	1.38	1.50	0.827	0.126	0.157	-	15,400	2,835	1.74
	mm	25.40	17.02	15.88	8.26	17.6	20.6	35.1	38.2	21.0	3.2	4.0	-	7,000	1,290	2.59
20BNP	inch	1.250	0.770	0.750	0.400	0.79	0.94	1.58	1.73	1.039	0.138	0.177	-	23,800	4,405	2.52
	mm	31.75	19.56	19.05	10.16	20.1	23.9	40.2	44.0	26.4	3.5	4.5	-	10,820	2,000	3.76

Chain Dimensions - Double Strand

06B-2NP	inch	0.375	0.225	0.250	0.130	0.45	0.48	0.90	0.93	0.323	0.040	0.050	0.403	4,360	675	0.54
	mm	9.525	5.72	6.35	3.28	11.4	12.3	22.9	23.7	8.2	1.0	1.25	10.24	1,980	307	0.81
08B-2NP	inch	0.500	0.305	0.335	0.175	0.60	0.65	1.20	1.26	0.465	0.060		0.548	7,760	1,205	0.84
	mm	12.70	7.75	8.51	4.45	15.3	16.6	30.6	31.9	11.8	1.5		13.92	3,525	548	1.26
10B-2NP	inch	0.625	0.380	0.400	0.200	0.70	0.77	1.40	1.47	0.579	0.065		0.653	11,200	1,875	1.20
	mm	15.875	9.65	10.16	5.08	17.8	19.5	35.6	37.3	14.7	1.65		16.59	5,090	852	1.79
12B-2NP	inch	0.750	0.460	0.475	0.225	0.82	0.88	1.64	1.70	0.634	0.070		0.766	14,390	2,700	1.53
	mm	19.05	11.68	12.07	5.7	20.8	22.3	41.6	43.1	16.1	1.8		19.46	6,540	1,225	2.28
16B-2NP	inch	1.000	0.670	0.625	0.325	1.32	1.44	2.64	2.76	0.827	0.126	0.157	1.255	30,300	4,810	3.44
	mm	25.40	17.02	15.88	8.26	33.6	36.5	67.2	70.1	21.0	3.2	4.0	31.88	13,775	2,185	5.13
20B-2NP	inch	1.250	0.770	0.750	0.400	1.51	1.66	3.02	3.17	1.039	0.138	0.177	1.435	46,700	7,485	4.87
	mm	31.75	19.56	19.05	10.16	38.4	42.2	76.8	80.6	26.4	3.5	4.5	36.45	21,225	3,400	7.26

ASME/ANSI Double Pitch Nickel Plated Roller Chain

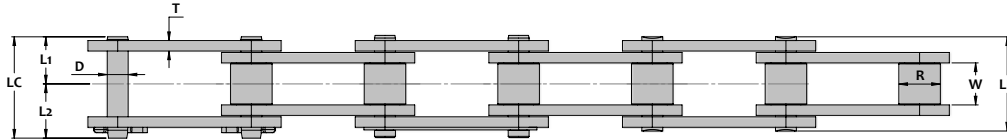

Standard Roller

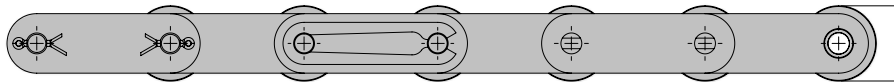
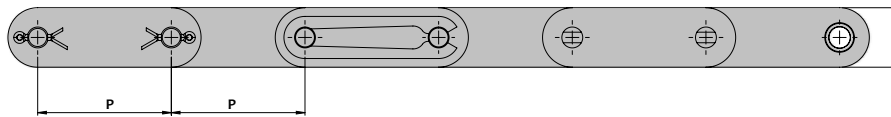

Large Roller

Chain Dimensions - Standard Roller

MAXCO Chain Number	Units	Chain Pitch P	Roller		Pin					Side Plate		Average Ultimate Strength Lbs Kg-f	Rated Working Load Lbs Kg-f	Average Chain Weight Lbs/ft Kg/m
			Dia.	Inside Width	Dia	Length				Height	Thick.			
			R	W	D	L1	L2	LR	LC	H	T			
C2040NP	inch	1.000	0.312	0.313	0.156	0.32	0.41	0.65	0.73	0.449	0.060	3,800	595	0.32
	mm	25.40	7.92	7.95	3.96	8.2	10.3	16.4	18.5	11.4	1.5	1,725	270	0.48
C2050NP	inch	1.250	0.400	0.375	0.200	0.40	0.46	0.80	0.87	0.591	0.080	6,200	970	0.55
	mm	31.75	10.16	9.53	5.08	10.2	11.8	20.4	22.0	15.0	2.0	2,820	441	0.82
C2060HNP	inch	1.500	0.469	0.500	0.234	0.57	0.65	1.13	1.22	0.669	0.126	9,050	1,865	0.93
	mm	38.10	11.91	12.70	5.95	14.4	16.6	28.8	31.0	17.0	3.2	4,115	848	1.38
C2080HNP	inch	2.000	0.625	0.625	0.312	0.70	0.83	1.40	1.53	0.890	0.157	15,500	3,415	1.56
	mm	50.80	15.88	15.88	7.93	17.8	21.0	35.6	38.8	22.6	4.0	7,045	1,550	2.32

Chain Dimensions - Large Roller

C2042NP	inch	1.000	0.625	0.313	0.156	0.32	0.41	0.65	0.73	0.449	0.060	3,800	595	0.55
	mm	25.40	15.88	7.95	3.96	8.2	10.3	16.4	18.5	11.4	1.5	1,725	270	0.82
C2052NP	inch	1.250	0.750	0.375	0.200	0.40	0.46	0.80	0.87	0.591	0.080	6,200	970	0.84
	mm	31.75	19.05	9.53	5.08	10.2	11.8	20.4	22.0	15.0	2.0	2,820	441	1.26
C2062HNP	inch	1.500	0.875	0.500	0.234	0.57	0.65	1.13	1.22	0.669	0.126	9,050	1,865	1.39
	mm	38.10	22.23	12.70	5.95	14.4	16.6	28.8	31.0	17.0	3.2	4,115	848	2.08
C2082HNP	inch	2.000	1.125	0.625	0.312	0.70	0.83	1.40	1.53	0.890	0.157	15,500	3,415	2.25
	mm	50.80	28.58	15.88	7.93	17.8	21.0	35.6	38.8	22.6	4.0	7,045	1,550	3.36



A Mechanical Rust Prevention System

Perfect Coat Plus II™ chains offer up to thirty times more protection from corrosive damage compared with conventional nickel plated products. These improved chains feature a mechanical rust prevention system which utilizes a zinc-alloy-iron film coating. The resulting film is extremely durable and will not chip, flake, peel or rust in many mildly corrosive applications.

Salt Water Corrosion Test

Roller chains submerged in and out of an aerated 5% salt water solution (equivalent to seawater). Carbon steel, nickel plated, Dip-Spin Zinc Chromate and Perfect Coat Plus II™ chains are tested for 14 days.

The Dip-Spin sample and Perfect Coat Plus II™ chain show significantly less rust after two weeks of testing.

Note that rust development on the Dip-Spin sample (Top in photo) begins where the bushing is press fitted into the link plate. When the chain was assembled, the coating chipped, peeled or flaked, causing a corrosive attack at this area. Eventually this rust will spread underneath the plated surface reducing chain life.



Traditional Dip-Spin Zinc-Chrome Coating

Nickel Plated

Carbon Steel

Perfect Coat Plus II™



Carbon Steel Chain



Nickel Plated Chain

After 2 weeks both the carbon steel and nickel plated chains exhibit substantial rust. The chain joints have frozen stiff making the chain difficult to flex.



Rust development at the press fit area.

Perfect Coat Plus II™ is a significantly more durable coating which does not chip, flake or peel. Virtually no rust developed on this sample.

ASME/ANSI Standard Perfect Coat Plus® Roller Chain

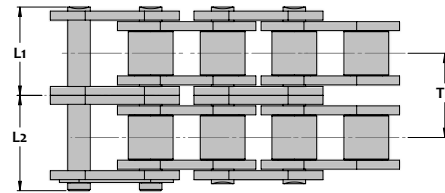
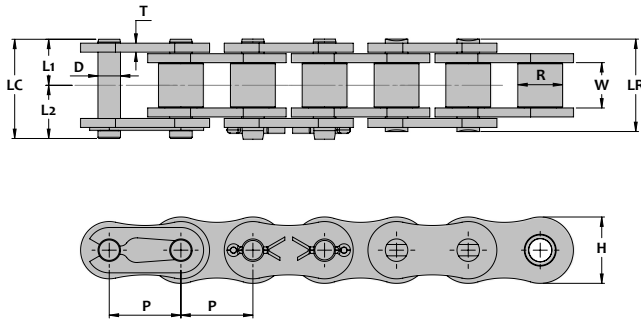

Chain Dimensions - Single Strand

MAXCO Chain Number	Units	Chain Pitch P	Roller			Pin				Side Plate		Trans. Pitch TP	Average Ultimate Strength Lbs Kg-f	Rated Working Load Lbs Kg-f	Average Chain Weight Lbs/ft Kg/m
			Dia.	Inside Width	Dia	Length			Height	Thick.					
			R	W	D	L1	L2	LR	LC	H	T				
35PCP	inch	0.375	0.200	0.188	0.141	0.24	0.27	0.47	0.51	0.354	0.050	-	2,430	560	0.23
	mm	9.525	5.08	4.78	3.58	6.0	6.9	12.0	12.9	9.0	1.25	-	1,105	255	0.34
40PCP	inch	0.500	0.312	0.313	0.156	0.33	0.38	0.65	0.70	0.461	0.060	-	4,300	940	0.40
	mm	12.70	7.92	7.95	3.96	8.3	9.6	16.6	17.9	11.7	1.5	-	1,955	427	0.60
50PCP	inch	0.625	0.400	0.375	0.200	0.40	0.46	0.80	0.87	0.575	0.080	-	7,200	1,625	0.66
	mm	15.875	10.16	9.53	5.08	10.2	11.8	20.4	22.0	14.6	2.0	-	3,275	739	0.98
60PCP	inch	0.750	0.469	0.500	0.234	0.50	0.56	1.00	1.06	0.689	0.094	-	10,000	2,405	0.98
	mm	19.05	11.91	12.70	5.95	12.8	14.1	25.5	26.9	17.5	2.4	-	4,545	1,095	1.46
80PCP	inch	1.000	0.625	0.625	0.312	0.65	0.75	1.29	1.40	0.921	0.126	-	17,650	4,295	1.69
	mm	25.4	15.88	15.88	7.93	16.4	19.1	32.8	35.5	23.4	3.2	-	8,025	1,950	2.52
100PCP	inch	1.250	0.75	0.750	0.375	0.78	0.92	1.55	1.69	1.154	0.157	-	26,500	6,610	2.62
	mm	31.75	19.05	19.05	9.53	19.7	23.3	39.4	43.0	29.3	4.0	-	12,045	3,005	3.91
120PCP	inch	1.500	0.875	1.000	0.437	0.98	1.13	1.95	2.10	1.382	0.188	-	39,000	8,880	3.86
	mm	38.10	22.23	25.40	11.10	24.8	28.6	49.5	53.4	35.1	4.8	-	17,725	4,035	5.76

Chain Dimensions - Double Strand

35-2PCP	inch	0.375	0.200	0.188	0.141	0.44	0.47	0.87	0.91	0.354	0.050	0.398	4,860	825	1.09
	mm	9.525	5.08	4.78	3.58	11.1	11.9	22.2	23.0	9.0	1.25	10.1	2,210	375	1.63
40-2PCP	inch	0.500	0.312	0.313	0.156	0.61	0.66	1.21	1.27	0.461	0.060	0.567	8,600	1,385	1.22
	mm	12.70	7.92	7.95	3.96	15.4	16.8	30.8	32.2	11.7	1.5	14.4	3,910	630	1.22
50-2PCP	inch	0.625	0.400	0.375	0.200	0.76	0.82	1.51	1.57	0.575	0.080	0.712	14,400	2,405	2.95
	mm	15.875	10.16	9.53	5.08	19.2	20.8	38.4	40.0	14.6	2.0	18.08	6,545	1,095	2.00
60-2PCP	inch	0.750	0.469	0.500	0.234	0.94	1.01	1.90	1.96	0.689	0.094	0.898	19,800	3,305	1.98
	mm	19.05	11.91	12.70	5.95	24.0	25.7	48.2	49.7	17.5	2.4	22.8	9,000	1,500	2.95
80-2PCP	inch	1.000	0.625	0.625	0.312	1.21	1.33	2.43	2.54	0.921	0.126	1.154	35,300	5,620	3.42
	mm	25.4	15.88	15.88	7.93	30.8	33.7	61.6	64.5	23.4	3.2	29.3	16,045	2,555	5.10

ISO 606B British Standard Perfect Coat Plus® Roller Chain

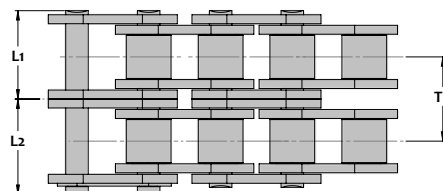
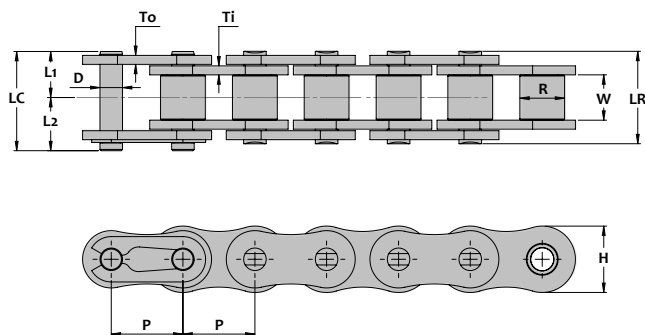

Chain Dimensions - Single Strand

MAXCO Chain Number	Units	Chain Pitch P	Roller		Pin					Side Plate		Trans. Pitch TP	Average Ultimate Strength Lbs Kg-f	Rated Working Load Lbs Kg-f	Average Chain Weight Lbs/ft Kg/m	
			Inside Width W	Dia. R	Dia. D	Length				Height H	Thickness					
						L1	L2	LR	LC		To					Ti
06BPCP	inch	0.375	0.225	0.250	0.130	0.25	0.28	0.50	0.53	0.323	0.040	0.050	-	2,200	400	0.29
	mm	9.525	5.72	6.35	3.28	6.3	7.1	12.6	13.4	8.2	1.0	1.25	-	1,000	182	0.43
08BPCP	inch	0.500	0.305	0.335	0.175	0.33	0.39	0.66	0.72	0.465	0.060		-	4,400	705	0.41
	mm	12.70	7.75	8.51	4.45	8.4	9.8	16.7	18.2	11.8	1.5		-	2,000	320	0.61
10BPCP	inch	0.625	0.380	0.400	0.200	0.37	0.44	0.75	0.81	0.579	0.065		-	5,600	1,100	0.60
	mm	15.875	9.65	10.16	5.08	9.5	11.2	19.0	20.7	14.7	1.65		-	5,600	500	0.89
12BPCP	inch	0.750	0.460	0.475	0.225	0.43	0.50	0.87	0.93	0.634	0.070		-	7,190	1,585	0.76
	mm	19.05	11.68	12.07	5.7	11.0	12.6	22.0	23.6	16.1	1.8		-	3,270	720	1.14
16BPCP	inch	1.000	0.670	0.625	0.325	0.69	0.81	1.38	1.50	0.827	0.126	0.157	-	15,400	2,835	1.74
	mm	25.40	17.02	15.88	8.26	17.6	20.6	35.1	38.2	21.0	3.2	4.0	-	7,000	1,290	2.59
20BPCP	inch	1.250	0.770	0.750	0.400	0.79	0.94	1.58	1.73	1.039	0.138	0.177	-	23,800	4,405	2.52
	mm	31.75	19.56	19.05	10.16	20.1	23.9	40.2	44.0	26.4	3.5	4.5	-	10,820	2,000	3.76

Chain Dimensions - Double Strand

06B-2PCP	inch	0.375	0.225	0.250	0.130	0.45	0.48	0.90	0.93	0.323	0.040	0.050	0.403	4,360	675	0.54
	mm	9.525	5.72	6.35	3.28	11.4	12.3	22.9	23.7	8.2	1.0	1.25	10.24	1,980	307	0.81
08B-2PCP	inch	0.500	0.305	0.335	0.175	0.60	0.65	1.20	1.26	0.465	0.060		0.548	7,760	1,205	0.84
	mm	12.70	7.75	8.51	4.45	15.3	16.6	30.6	31.9	11.8	1.5		13.92	3,525	548	1.26
10B-2PCP	inch	0.625	0.380	0.400	0.200	0.70	0.77	1.40	1.47	0.579	0.065		0.653	11,200	1,875	1.20
	mm	15.875	9.65	10.16	5.08	17.8	19.5	35.6	37.3	14.7	1.65		16.59	5,090	852	1.79
12B-2PCP	inch	0.750	0.460	0.475	0.225	0.82	0.88	1.64	1.70	0.634	0.070		0.766	14,390	2,700	1.53
	mm	19.05	11.68	12.07	5.7	20.8	22.3	41.6	43.1	16.1	1.8		19.46	6,540	1,225	2.28
16B-2PCP	inch	1.000	0.670	0.625	0.325	1.32	1.44	2.64	2.76	0.827	0.126	0.157	1.255	30,300	4,810	3.44
	mm	25.40	17.02	15.88	8.26	33.6	36.5	67.2	70.1	21.0	3.2	4.0	31.88	13,775	2,185	5.13
20B-2PCP	inch	1.250	0.770	0.750	0.400	1.51	1.66	3.02	3.17	1.039	0.138	0.177	1.435	46,700	7,485	4.87
	mm	31.75	19.56	19.05	10.16	38.4	42.2	76.8	80.6	26.4	3.5	4.5	36.45	21,225	3,400	7.26

ASME/ANSI Double Pitch Perfect Coat Plus® Roller Chain

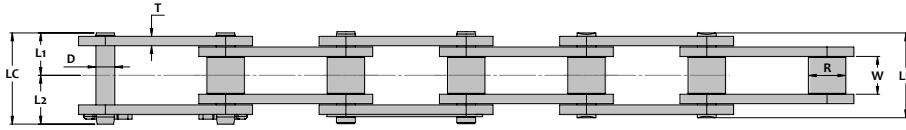

Standard Roller

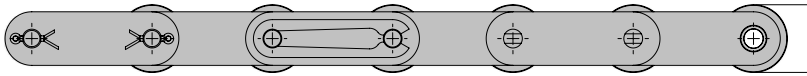
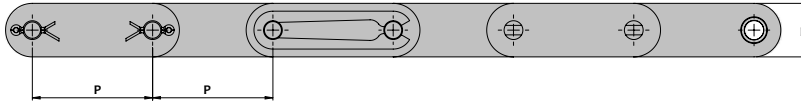

Large Roller

Chain Dimensions - Standard Roller

MAXCO Chain Number	Units	Chain Pitch P	Roller			Pin				Side Plate		Average Ultimate Strength Lbs Kg-f	Rated Working Load Lbs Kg-f	Average Chain Weight Lbs/ft Kg/m
			Dia	Inside Width	Dia	Length			Height	Thick.				
			R	W		L1	L2	LR			LC			
C2040PCP	inch	1.000	0.312	0.313	0.156	0.32	0.41	0.65	0.73	0.449	0.060	3,800	815	0.32
	mm	25.40	7.92	7.95	3.96	8.2	10.3	16.4	18.5	11.4	1.5	1,725	370	0.48
C2050PCP	inch	1.250	0.400	0.375	0.200	0.40	0.46	0.80	0.87	0.591	0.080	6,200	1,410	0.55
	mm	31.75	10.16	9.53	5.08	10.2	11.8	20.4	22.0	15.0	2.0	2,820	641	0.82
C2060HPCP	inch	1.500	0.469	0.500	0.234	0.57	0.65	1.13	1.22	0.669	0.126	9,050	1,940	0.93
	mm	38.10	11.91	12.70	5.95	14.4	16.6	28.8	31.0	17.0	3.2	4,115	882	1.38
C2080HPCP	inch	2.000	0.625	0.625	0.312	0.70	0.83	1.40	1.53	0.890	0.157	15,500	3,305	1.56
	mm	50.80	15.88	15.88	7.93	17.8	21.0	35.6	38.8	22.6	4.0	7,045	1,500	2.32
C2100HPCP	inch	2.500	0.750	0.750	0.375	0.83	0.97	1.66	1.80	1.126	0.189	24,300	5,080	2.32
	mm	63.50	19.05	19.05	9.53	21.1	24.6	42.2	45.7	28.6	4.8	11,045	2,310	3.46
C2120HPCP	inch	3.000	0.875	1.000	0.437	1.04	1.21	2.07	2.24	1.374	0.220	34,000	6,830	3.30
	mm	76.20	22.23	25.40	11.10	26.3	30.7	52.6	57.0	34.9	5.6	15,455	3,105	4.92

Chain Dimensions - Large Roller

C2042PCP	inch	1.000	0.625	0.313	0.156	0.32	0.41	0.65	0.73	0.449	0.060	3,800	815	0.55
	mm	25.40	15.88	7.95	3.96	8.2	10.3	16.4	18.5	11.4	1.5	1,725	370	0.82
C2052PCP	inch	1.250	0.750	0.375	0.200	0.40	0.46	0.80	0.87	0.591	0.080	6,200	1,410	0.84
	mm	31.75	19.05	9.53	5.08	10.2	11.8	20.4	22.0	15.0	2.0	2,820	641	1.26
C2062HPCP	inch	1.500	0.875	0.500	0.234	0.57	0.65	1.13	1.22	0.669	0.126	9,050	1,940	1.39
	mm	38.10	22.23	12.70	5.95	14.4	16.6	28.8	31.0	17.0	3.2	4,115	882	2.08
C2082HPCP	inch	2.000	1.125	0.625	0.312	0.70	0.83	1.40	1.53	0.890	0.157	15,500	3,305	2.25
	mm	50.80	28.58	15.88	7.93	17.8	21.0	35.6	38.8	22.6	4.0	7,045	1,500	3.36
C2102HPCP	inch	2.500	1.562	0.750	0.375	0.83	0.97	1.66	1.80	1.126	0.189	24,300	5,080	3.78
	mm	63.50	39.67	19.05	9.53	21.1	24.6	42.2	45.7	28.6	4.8	11,045	2,310	5.64
C2122HPCP	inch	3.000	1.750	1.000	0.437	1.04	1.21	2.07	2.24	1.374	0.220	34,000	6,830	5.28
	mm	76.20	44.45	25.40	11.10	26.3	30.7	52.6	57.0	34.9	5.6	15,455	3,105	7.87

Stainless Steel Roller Chain - General Information

General Information - Stainless Steels

Type 304 Stainless All parts are made from AISI Type 304 (18-8) austenitic stainless steel. This material offers very good chemical and temperature resistance in a wide range of diverse applications. Because Type 304 stainless steel cannot be heat treated the mechanical strength and wear performance is inferior to standard carbon steel chains.

Type 316 Stainless All parts are made from AISI Type 316 Molybdenum-bearing stainless steel. The molybdenum gives the alloy better overall corrosion resistance compared with Type 304 stainless steel particularly higher resistance to pitting and stress corrosion cracking in the presence of chlorides. Mechanical strength and wear performance are similar to Type 304 stainless steel chain.

600 Series Stainless Pins, bushings and rollers are made from 17-4PH stainless steels which can be age hardened for improved resistance to wear elongation. The corrosion resistance of this series is similar (though slightly inferior) to Type 304 stainless steel. The operating temperature range of this material however is also not as wide as Type 304 stainless steel.

Mega Chain: All parts are made from AISI Type 304 (18-8) austenitic stainless steel. Available in two versions (Mega Chain and Mega Chain II) which use different physical configurations to obtain additional strength that is similar to that of carbon steel chains. The working loads of these chains are superior to that of standard 304 stainless steel chains due to a greater pin/bushing bearing areas. In addition both versions possess a unique labyrinth type seal design that helps prevent the penetration of abrasive foreign materials to the internal wearing components.

Component Materials and Rated Working Load

Stainless Series	Pin	Bushing	Roller	Link Plate	Max. Allowable Bearing Pressure	Allowable Speed (max)
304 Stainless	AISI 304SS (18-8)	AISI 304SS (18-8)	AISI 304SS (18-8)	AISI 304SS (18-8)	1,420 psi	230 ft/min
					9,791 KPA	70.1 m/min
316 Stainless	AISI 316SS	Type 316SS	Type 316SS	Type 316SS	1,420 psi	230 ft/min
					9,791 KPA	70.1 m/min
600 Stainless	17-4PH	17-7PH	17-7PH*	AISI 304SS (18-8)	2,130 psi	230 ft/min
					14,686 KPA	70.1 m/min
Mega Chain	AISI 304SS (18-8)	AISI 304SS (18-8)	AISI 304SS (18-8)	AISI 304SS (18-8)	1,420 psi	230 ft/min
					9,791 KPA	70.1 m/min

* Double Pitch Chains with Large Rollers utilize Type 304SS

General Properties of Stainless Steel Roller Chain Products

Chain	Corrosion Resistance	Temperature Resistance	Wear Resistance	Strength	Magnetism
AISI 304 Stainless	Very Good	-250°F - 750°F -155°C - 400°C	Fair	Fair	Slightly Magnetic
AISI 316 Stainless	Excellent	-250°F - 950°F -155°C - 510°C	Fair	Fair	Non-magnetic
600 Stainless	Very Good	-50°F - 750°F -45°C - 400°C	Very Good	Fair	Slightly Magnetic
Mega Chain	Very Good	-250°F - 750°F -155°C - 400°C	Very Good	Excellent	Slightly Magnetic

ASME/ANSI Standard 304 Stainless Steel Roller Chain

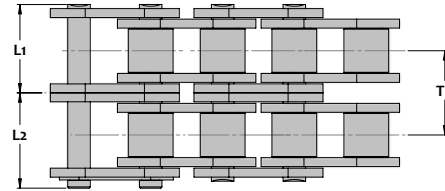
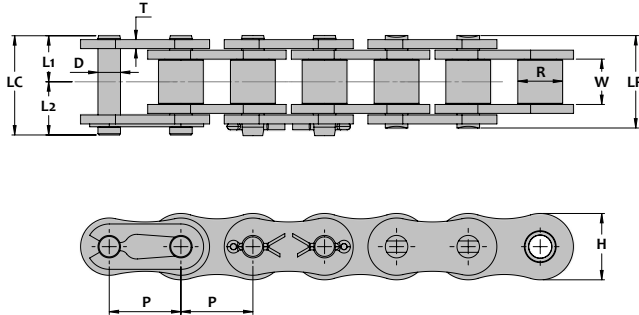

Chain Dimensions - Single Strand

MAXCO Chain Number	Units	Chain Pitch P	Roller			Pin				Side Plate		Trans. Pitch TP	Average Ultimate Strength Lbs Kg-f	Rated Working Load Lbs Kg-f	Average Chain Weight Lbs/ft Kg/m
			Dia. R	Inside Width W	Dia. D	Length				Height H	Thick. T				
						L1	L2	LR	LC						
25SS	inch	0.250	0.130	0.125	0.091	0.15	0.19	0.30	0.34	0.230	0.030	-	700	27	0.10
	mm	6.35	3.20	3.18	2.31	3.8	4.8	7.6	8.6	5.84	0.76	-	318	12	0.15
35SS	inch	0.375	0.200	0.188	0.141	0.24	0.27	0.47	0.51	0.354	0.050	-	1,400	60	0.23
	mm	9.525	5.08	4.78	3.58	6.0	6.9	12.0	12.9	9.0	1.25	-	636	27	0.34
41SS	inch	0.500	0.306	0.250	0.141	0.26	0.31	0.52	0.57	0.382	0.050	-	1,700	70	0.30
	mm	12.70	7.77	6.35	3.58	6.6	7.9	13.2	14.5	9.7	1.25	-	773	32	0.45
40SS	inch	0.500	0.312	0.313	0.156	0.33	0.38	0.65	0.70	0.461	0.060	-	2,790	100	0.40
	mm	12.70	7.92	7.95	3.96	8.3	9.6	16.6	17.9	11.7	1.5	-	1,270	45	0.60
50SS	inch	0.625	0.400	0.375	0.200	0.40	0.46	0.80	0.87	0.575	0.080	-	4,560	150	0.66
	mm	15.875	10.16	9.53	5.08	10.2	11.8	20.4	22.0	14.6	2.0	-	2,075	68	0.98
60SS	inch	0.750	0.469	0.500	0.234	0.50	0.56	1.00	1.06	0.689	0.094	-	6,160	230	0.98
	mm	19.05	11.91	12.70	5.95	12.8	14.1	25.5	26.9	17.5	2.4	-	2,800	105	1.46
80SS	inch	1.000	0.625	0.625	0.312	0.65	0.75	1.29	1.40	0.921	0.126	-	10,590	400	1.69
	mm	25.4	15.88	15.88	7.93	16.4	19.1	32.8	35.5	23.4	3.2	-	4,815	182	2.52
100SS	inch	1.250	0.75	0.750	0.375	0.78	0.92	1.55	1.69	1.154	0.157	-	12,790	570	2.62
	mm	31.75	19.05	19.05	9.53	19.7	23.3	39.4	43.0	29.3	4.0	-	5,815	259	3.91

Chain Dimensions - Double Strand

35-2SS	inch	0.375	0.200	0.188	0.141	0.44	0.47	0.87	0.91	0.354	0.050	0.398	2,800	120	1.09
	mm	9.525	5.08	4.78	3.58	11.1	11.9	22.2	23.0	9.0	1.25	10.1	1,275	55	1.63
40-2SS	inch	0.500	0.312	0.313	0.156	0.61	0.66	1.21	1.27	0.461	0.060	0.567	5,580	200	1.22
	mm	12.70	7.92	7.95	3.96	15.4	16.8	30.8	32.2	11.7	1.5	14.4	2,535	91	1.22
50-2SS	inch	0.625	0.400	0.375	0.200	0.76	0.82	1.51	1.57	0.575	0.080	0.712	9,120	310	2.95
	mm	15.875	10.16	9.53	5.08	19.2	20.8	38.4	40.0	14.6	2.0	18.08	4,145	141	2.00
60-2SS	inch	0.750	0.469	0.500	0.234	0.94	1.01	1.90	1.96	0.689	0.094	0.898	12,320	460	1.98
	mm	19.05	11.91	12.70	5.95	24.0	25.7	48.2	49.7	17.5	2.4	22.8	5,600	209	2.95
80-2SS	inch	1.000	0.625	0.625	0.312	1.21	1.33	2.43	2.54	0.921	0.126	1.154	21,180	800	3.42
	mm	25.4	15.88	15.88	7.93	30.8	33.7	61.6	64.5	23.4	3.2	29.3	9,625	364	5.10

ISO 606B British Standard 304 Stainless Steel Roller Chain

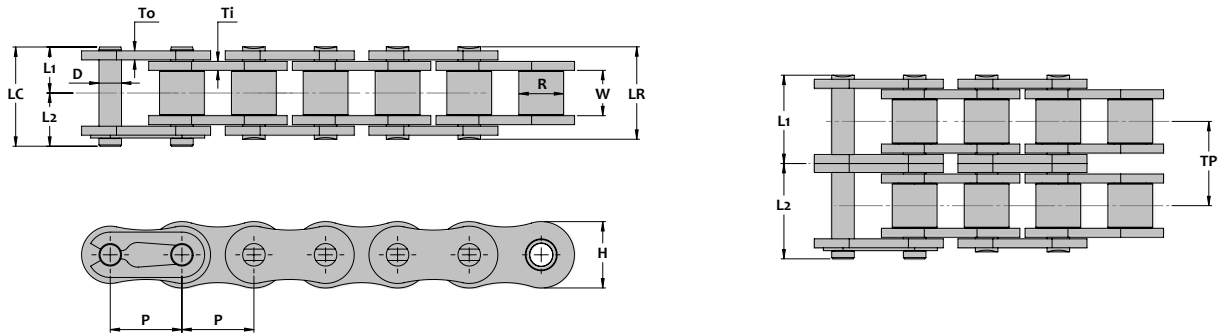

Chain Dimensions - Single Strand

MAXCO Chain Number	Units	Chain Pitch P	Roller			Pin				Side Plate		Trans. Pitch TP	Minimum Ultimate Strength Lbs Kg-f	Rated Working Load Lbs Kg-f	Average Chain Weight Lbs/ft Kg/m	
			Inside Width W	Dia. R	Dia. D	Length				Height H	Thickness					
						L1	L2	LR	LC	To	Ti					
06BSS	inch	0.375	0.225	0.250	0.130	0.25	0.28	0.50	0.53	0.323	0.040	0.050	-	1,390	60	0.29
	mm	9.525	5.72	6.35	3.28	6.3	7.1	12.6	13.4	8.2	1.0	1.25	-	632	27	0.43
08BSS	inch	0.500	0.305	0.335	0.175	0.33	0.39	0.66	0.72	0.465	0.060		-	2,315	105	0.41
	mm	12.70	7.75	8.51	4.45	8.4	9.8	16.7	18.2	11.8	1.5		-	1,050	48	0.61
10BSS	inch	0.625	0.380	0.400	0.200	0.37	0.44	0.75	0.81	0.579	0.065		-	3,530	145	0.60
	mm	15.875	9.65	10.16	5.08	9.5	11.2	19.0	20.7	14.7	1.65		-	1,605	66	0.89
12BSS	inch	0.750	0.460	0.475	0.225	0.43	0.50	0.87	0.93	0.634	0.070		-	4,070	195	0.76
	mm	19.05	11.68	12.07	5.7	11.0	12.6	22.0	23.6	16.1	1.8		-	1,850	89	1.14
16BSS	inch	1.000	0.670	0.625	0.325	0.69	0.81	1.38	1.50	0.827	0.126	0.157	-	9,490	455	1.74
	mm	25.40	17.02	15.88	8.26	17.6	20.6	35.1	38.2	21.0	3.2	4.0	-	4,315	207	2.59

Chain Dimensions - Double Strand

06B-2SS	inch	0.375	0.225	0.250	0.130	0.45	0.48	0.90	0.93	0.323	0.040	0.050	0.403	2,780	120	0.54
	mm	9.525	5.72	6.35	3.28	11.4	12.3	22.9	23.7	8.2	1.0	1.25	10.24	1,265	55	0.81
08B-2SS	inch	0.500	0.305	0.335	0.175	0.60	0.65	1.20	1.26	0.465	0.060		0.548	4,630	210	0.84
	mm	12.70	7.75	8.51	4.45	15.3	16.6	30.6	31.9	11.8	1.5		13.92	2,105	95	1.26
10B-2SS	inch	0.625	0.380	0.400	0.200	0.70	0.77	1.40	1.47	0.579	0.065		0.653	7,060	290	1.20
	mm	15.875	9.65	10.16	5.08	17.8	19.5	35.6	37.3	14.7	1.65		16.59	3,210	132	1.79
12B-2SS	inch	0.750	0.460	0.475	0.225	0.82	0.88	1.64	1.70	0.634	0.070		0.766	8,140	390	1.53
	mm	19.05	11.68	12.07	5.7	20.8	22.3	41.6	43.1	16.1	1.8		19.46	3,700	177	2.28
16B-2SS	inch	1.000	0.670	0.625	0.325	1.32	1.44	2.64	2.76	0.827	0.126	0.157	1.255	18,970	910	3.44
	mm	25.40	17.02	15.88	8.26	33.6	36.5	67.2	70.1	21.0	3.2	4.0	31.88	8,625	414	5.13

ASME/ANSI Double Pitch 304 Stainless Steel Roller Chain

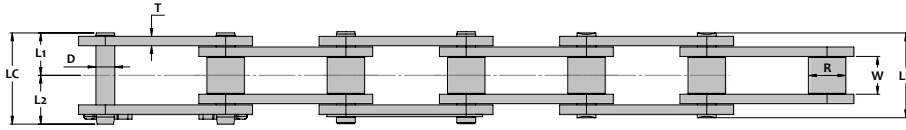

Standard Roller

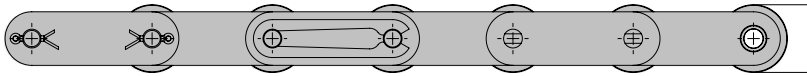
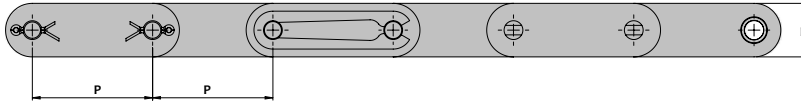

Large Roller

Chain Dimensions - Standard Roller

MAXCO Chain Number	Units	Chain Pitch P	Roller			Pin				Side Plate		Average Ultimate Strength Lbs Kg-f	Rated Working Load Lbs Kg-f	Average Chain Weight Lbs/ft Kg/m
			Dia	Inside Width	Dia	Length				Height	Thick.			
			R	W	D	L1	L2	LR	LC	H	T			
C2040SS	inch	1.000	0.312	0.313	0.156	0.32	0.41	0.65	0.73	0.449	0.060	2,790	100	0.32
	mm	25.40	7.92	7.95	3.96	8.2	10.3	16.4	18.5	11.4	1.5	1,270	45	0.48
C2050SS	inch	1.250	0.400	0.375	0.200	0.40	0.46	0.80	0.87	0.591	0.080	4,560	150	0.55
	mm	31.75	10.16	9.53	5.08	10.2	11.8	20.4	22.0	15.0	2.0	2,075	68	0.82
C2060HSS	inch	1.500	0.469	0.500	0.234	0.57	0.65	1.13	1.22	0.669	0.126	6,160	250	0.93
	mm	38.10	11.91	12.70	5.95	14.4	16.6	28.8	31.0	17.0	3.2	2,800	114	1.38
C2080HSS	inch	2.000	0.625	0.625	0.312	0.70	0.83	1.40	1.53	0.890	0.157	10,590	420	1.56
	mm	50.80	15.88	15.88	7.93	17.8	21.0	35.6	38.8	22.6	4.0	4,815	191	2.32
C2100HSS	inch	2.500	0.750	0.750	0.375	0.83	0.97	1.66	1.80	1.126	0.189	12,790	600	2.32
	mm	63.50	19.05	19.05	9.53	21.1	24.6	42.2	45.7	28.6	4.8	5,815	273	3.46
C2120HSS	inch	3.000	0.875	1.000	0.437	1.04	1.21	2.07	2.24	1.374	0.220	17,200	900	3.30
	mm	76.20	22.23	25.40	11.10	26.3	30.7	52.6	57.0	34.9	5.6	7,820	409	4.92

Chain Dimensions - Large Roller

C2042SS	inch	1.000	0.625	0.313	0.156	0.32	0.41	0.65	0.73	0.449	0.060	2,790	100	0.55
	mm	25.40	15.88	7.95	3.96	8.2	10.3	16.4	18.5	11.4	1.5	1,270	45	0.82
C2052SS	inch	1.250	0.750	0.375	0.200	0.40	0.46	0.80	0.87	0.591	0.080	4,560	150	0.84
	mm	31.75	19.05	9.53	5.08	10.2	11.8	20.4	22.0	15.0	2.0	2,075	68	1.26
C2062HSS	inch	1.500	0.875	0.500	0.234	0.57	0.65	1.13	1.22	0.669	0.126	6,160	250	1.39
	mm	38.10	22.23	12.70	5.95	14.4	16.6	28.8	31.0	17.0	3.2	2,800	114	2.08
C2082HSS	inch	2.000	1.125	0.625	0.312	0.70	0.83	1.40	1.53	0.890	0.157	10,590	420	2.25
	mm	50.80	28.58	15.88	7.93	17.8	21.0	35.6	38.8	22.6	4.0	4,815	191	3.36
C2102HSS	inch	2.500	1.562	0.750	0.375	0.83	0.97	1.66	1.80	1.126	0.189	12,790	600	3.78
	mm	63.50	39.67	19.05	9.53	21.1	24.6	42.2	45.7	28.6	4.8	5,815	273	5.64
C2122HSS	inch	3.000	1.750	1.000	0.437	1.04	1.21	2.07	2.24	1.374	0.220	17,200	900	5.28
	mm	76.20	44.45	25.40	11.10	26.3	30.7	52.6	57.0	34.9	5.6	7,820	409	7.87

ASME/ANSI Double Pitch 304 Stainless Steel-Plastic Rollers

Plastic Roller Double Pitch chains are made with 304 stainless steel (AISI 18-8) components. The roller is a polyacetal resin which provides smooth quiet operation, resists corrosion and is ideal for a wide variety of conveyor applications. Attachments are available. Care must be taken not to exceed the Rated Working Load of the rollers (shown in the table below) when the chain is directly carrying the weight of the conveyed product. The rated working load of the chain itself due to chain tension is also reduced as a result of reduced allowable loads between the plastic roller and the sprocket teeth.

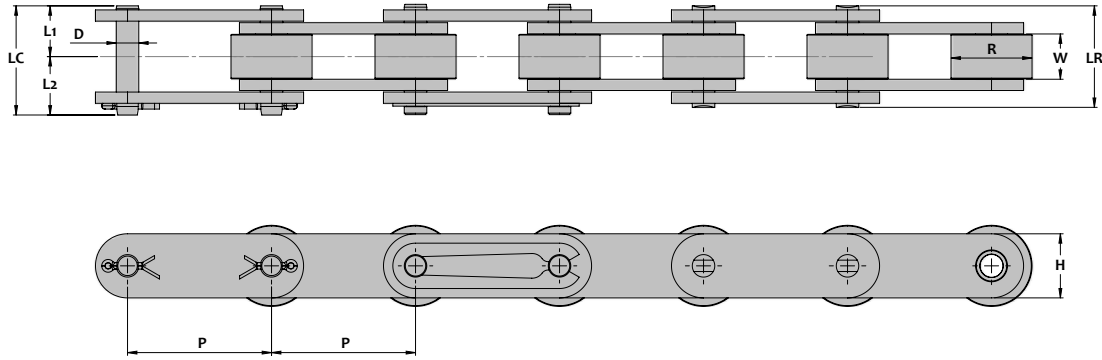

Chain Dimensions - Large Plastic Roller

MAXCO Chain Number	Units	Chain Pitch P	Roller			Pin				Side Plate		Average Ultimate Strength Lbs Kg-f	Rated Working Load		Roller Crush Strength Lbs Kg-f	Average Chain Weight Lbs/ft Kg/m
			Dia	Inside Width	Dia	Length				Height	Thick.		Chain Tension	Roller Load		
			R	W	D	L1	L2	LR	LC	H	T		Lbs Kg-f	Lbs Kg-f		
C2042SS-D	inch	1.000	0.625	0.313	0.156	0.32	0.41	0.65	0.73	0.449	0.060	2,790	100	45	550	0.33
	mm	25.40	15.88	7.95	3.96	8.2	10.3	16.4	18.5	11.4	1.5	1,270	45	20	250	0.49
C2052SS-D	inch	1.250	0.750	0.375	0.200	0.40	0.46	0.80	0.87	0.591	0.080	4,560	160	70	770	0.57
	mm	31.75	19.05	9.53	5.08	10.2	11.8	20.4	22.0	15.0	2.0	2,075	73	32	350	0.85
C2062HSS-D	inch	1.500	0.875	0.500	0.234	0.57	0.65	1.13	1.22	0.669	0.126	6,160	230	110	880	0.98
	mm	38.10	22.23	12.70	5.95	14.4	16.6	28.8	31.0	17.0	3.2	2,800	105	50	400	1.46
C2082HSS-D	inch	2.000	1.125	0.625	0.312	0.70	0.83	1.40	1.53	0.890	0.157	10,590	400	200	1,540	1.77
	mm	50.80	28.58	15.88	7.93	17.8	21.0	21.0	35.6	22.6	4.0	4,815	182	91	700	2.64

ASME/ANSI Standard Pitch 600 Stainless Steel Roller Chain

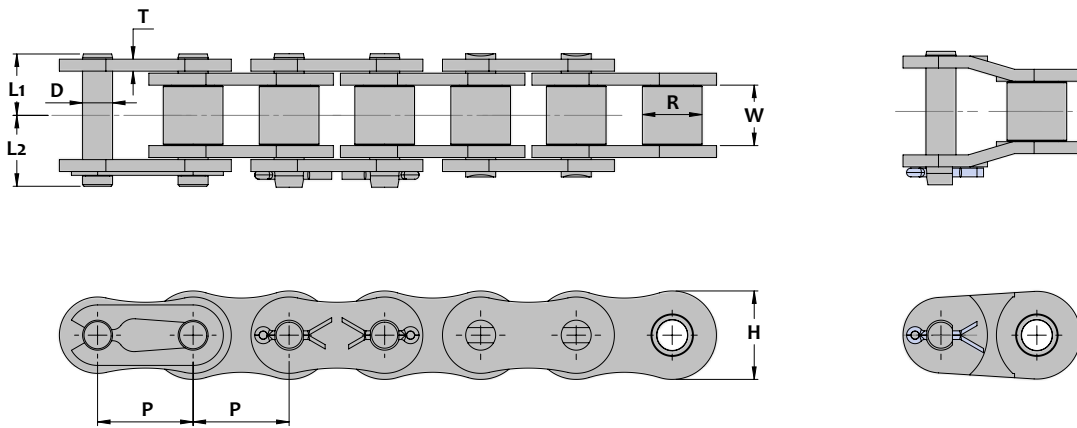

Chain Dimensions

MAXCO Chain Number	Units	Chain Pitch P	Roller		Dia. D	Pin		Side Plate		Average Ultimate Strength Lbs Kg-f	Rated Working Load Lbs Kg-f	Average Chain Weight Lbs/ft Kg/m
			Dia. R	Inside Width W		Length	Height	Thick.				
						L1	L2	H	T			
35SS600	inch	0.375	0.200	0.188	0.141	0.23	0.28	0.356	0.050	1,400	90	0.21
	mm	9.525	5.08	4.78	3.58	5.9	7.0	9.04	1.27	636	41	0.32
40SS600	inch	0.500	0.312	0.313	0.156	0.32	0.69	0.475	0.060	2,790	150	0.42
	mm	12.70	7.92	7.95	3.96	8.2	17.5	12.1	1.5	1,270	68	0.62
50SS600	inch	0.625	0.400	0.375	0.200	0.40	0.49	0.594	0.080	4,560	225	0.68
	mm	15.875	10.16	9.53	5.08	10.2	12.4	15.1	2.0	2,075	102	1.01
60SS600	inch	0.750	0.469	0.500	0.234	0.50	0.60	0.712	0.094	6,160	345	0.97
	mm	19.05	11.91	12.70	5.95	12.7	15.3	18.1	2.4	2,800	157	1.45
80SS600	inch	1.000	0.625	0.625	0.312	0.65	0.80	0.950	0.125	10,590	600	1.72
	mm	25.4	15.88	15.88	7.93	16.5	20.4	24.1	3.2	4,815	273	2.56

ASME/ANSI Double Pitch 600 Stainless Steel Roller Chain

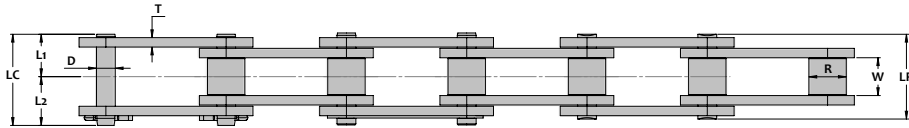

Standard Roller

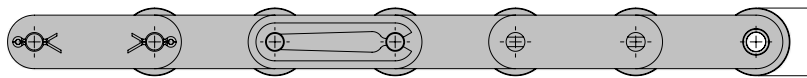
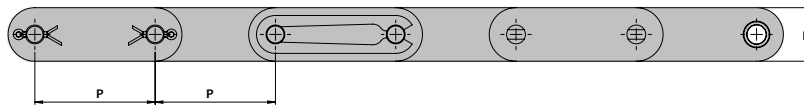

Large Roller

Chain Dimensions - Standard Roller

MAXCO Chain Number	Units	Chain Pitch P	Roller			Pin				Side Plate		Average Ultimate Strength Lbs Kg-f	Rated Working Load Lbs Kg-f	Average Chain Weight Lbs/ft Kg/m
			Dia R	Inside Width W	Dia D	Length				Height H	Thick. T			
						L1	L2	LR	LC					
C2040SS600	inch	1.000	0.312	0.313	0.156	0.32	0.41	0.65	0.73	0.475	0.060	2,790	150	0.32
	mm	25.40	7.92	7.95	3.96	8.2	10.3	16.4	18.5	12.06	1.5	1,270	68	0.47
C2050SS600	inch	1.250	0.400	0.375	0.200	0.40	0.49	0.80	0.89	0.594	0.080	4,560	225	0.54
	mm	31.75	10.16	9.53	5.08	10.2	12.4	20.3	22.6	15.1	2.0	2,075	102	0.80
C2060HSS600	inch	1.500	0.469	0.500	0.234	0.57	0.67	1.13	1.23	0.712	0.125	6,160	375	0.95
	mm	38.10	11.91	12.70	5.95	14.4	16.9	28.8	31.3	18.1	3.2	2,800	170	1.41
C2080HSS600	inch	2.000	0.625	0.625	0.312	0.71	0.89	1.43	1.60	0.950	0.156	10,590	630	1.60
	mm	50.80	15.88	15.88	7.93	18.2	22.6	36.3	40.7	24.1	4.0	4,815	268	2.38

Chain Dimensions - Large Roller

C2042SS600	inch	1.000	0.625	0.313	0.156	0.32	0.41	0.65	0.73	0.475	0.060	2,790	150	0.56
	mm	25.40	15.88	7.95	3.96	8.2	10.3	16.4	18.5	12.06	1.5	1,270	68	0.83
C2052SS600	inch	1.250	0.750	0.375	0.200	0.40	0.49	0.80	0.89	0.594	0.080	4,560	225	0.85
	mm	31.75	19.05	9.53	5.08	10.2	12.4	20.3	22.6	15.1	2.0	2,075	102	1.27
C2062HSS600	inch	1.500	0.875	0.500	0.234	0.57	0.67	1.13	1.23	0.712	0.125	6,160	375	1.43
	mm	38.10	22.23	12.70	5.95	14.4	16.9	28.8	31.3	18.1	3.2	2,800	170	2.13
C2082HSS600	inch	2.000	1.125	0.625	0.312	0.71	0.89	1.43	1.60	0.950	0.156	10,590	630	2.31
	mm	50.80	28.58	15.88	7.93	18.2	22.6	36.3	40.7	24.1	4.0	4,815	268	3.45

ASME/ANSI Standard Pitch 316 Stainless Steel Roller Chain

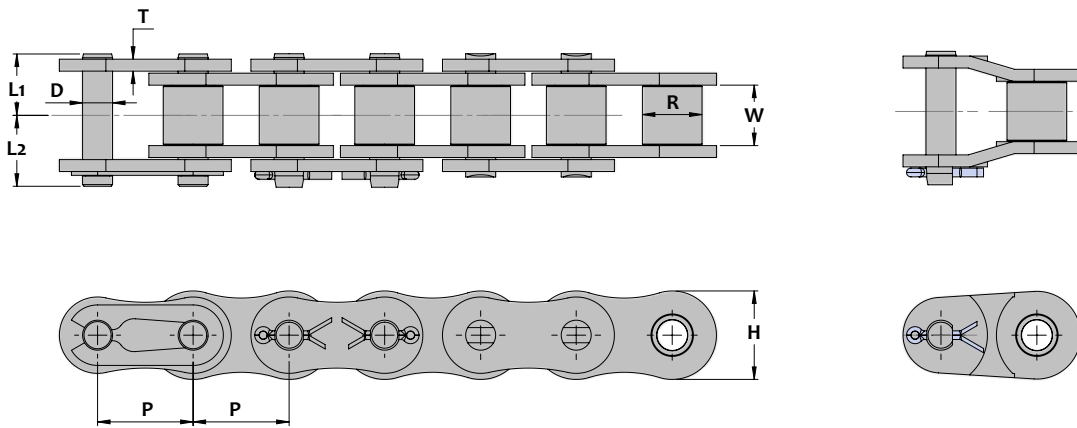

Chain Dimensions

MAXCO Chain Number	Units	Chain Pitch P	Roller		Dia D	Pin		Side Plate		Average Ultimate Strength Lbs Kg-f	Rated Working Load Lbs Kg-f	Average Chain Weight Lbs/ft Kg/m
			Dia. R	Inside Width W		Dia	Length	Height H	Thick. T			
						L1	L2					
40SS316	inch	0.500	0.312	0.313	0.156	0.32	0.69	0.475	0.060	2,790	100	0.42
	mm	12.70	7.92	7.95	3.96	8.2	17.5	12.1	1.5	1,270	45	0.62
50SS316	inch	0.625	0.400	0.375	0.200	0.40	0.49	0.594	0.080	4,560	150	0.68
	mm	15.875	10.16	9.53	5.08	10.2	12.4	15.1	2.0	2,075	68	1.01
60SS316	inch	0.750	0.469	0.500	0.234	0.50	0.60	0.712	0.094	6,160	230	0.97
	mm	19.05	11.91	12.70	5.95	12.7	15.3	18.1	2.4	2,800	105	1.45
80SS316	inch	1.000	0.625	0.625	0.312	0.65	0.80	0.950	0.125	10,590	400	1.72
	mm	25.4	15.88	15.88	7.93	16.5	20.4	24.1	3.2	4,815	182	2.56

ASME/ANSI Double Pitch 316 Stainless Steel Roller Chain

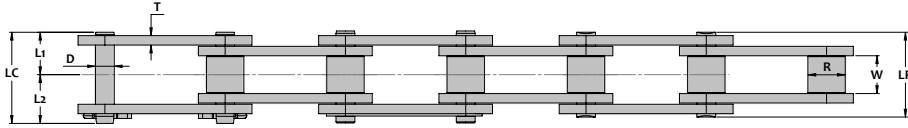

Standard Roller

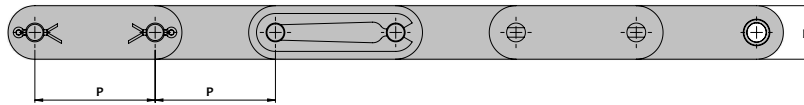

Large Roller

Chain Dimensions - Standard Roller

MAXCO Chain Number	Units	Chain Pitch P	Roller			Pin					Side Plate		Average Ultimate Strength Lbs Kg-f	Rated Working Load Lbs Kg-f	Average Chain Weight Lbs/ft Kg/m
			Dia R	Inside Width W	Dia D	Length				Height H	Thick. T				
						L1	L2	LR	LC						
C2040SS316	inch	1.000	0.312	0.313	0.156	0.32	0.41	0.65	0.73	0.475	0.060	3,800	100	0.32	
	mm	25.40	7.92	7.95	3.96	8.2	10.3	16.4	18.5	12.06	1.5	1,725	45	0.47	
C2050SS316	inch	1.250	0.400	0.375	0.200	0.40	0.49	0.80	0.89	0.594	0.080	6,180	150	0.54	
	mm	31.75	10.16	9.53	5.08	10.2	12.4	20.3	22.6	15.1	2.0	2,810	68	0.80	
C2060HSS316	inch	1.500	0.469	0.500	0.234	0.57	0.67	1.13	1.23	0.712	0.125	9,040	250	0.95	
	mm	38.10	11.91	12.70	5.95	14.4	16.9	28.8	31.3	18.1	3.2	4,110	114	1.41	
C2080HSS316	inch	2.000	0.625	0.625	0.312	0.71	0.89	1.43	1.60	0.950	0.156	15,420	420	1.60	
	mm	50.80	15.88	15.88	7.93	18.2	22.6	36.3	40.7	24.1	4.0	7,010	191	2.38	

Chain Dimensions - Large Roller

C2042SS316	inch	1.000	0.625	0.313	0.156	0.32	0.41	0.65	0.73	0.475	0.060	3,800	100	0.56
	mm	25.40	15.88	7.95	3.96	8.2	10.3	16.4	18.5	12.06	1.5	1,725	45	0.83
C2052SS316	inch	1.250	0.750	0.375	0.200	0.40	0.49	0.80	0.89	0.594	0.080	6,180	150	0.85
	mm	31.75	19.05	9.53	5.08	10.2	12.4	20.3	22.6	15.1	2.0	2,810	68	1.27
C2062HSS316	inch	1.500	0.875	0.500	0.234	0.57	0.67	1.13	1.23	0.712	0.125	9,040	250	1.43
	mm	38.10	22.23	12.70	5.95	14.4	16.9	28.8	31.3	18.1	3.2	4,110	114	2.13
C2082HSS316	inch	2.000	1.125	0.625	0.312	0.71	0.89	1.43	1.60	0.950	0.156	15,420	420	2.31
	mm	50.80	28.58	15.88	7.93	18.2	22.6	36.3	40.7	24.1	4.0	7,010	191	3.45

*Take a new look
at an old product...*



We've totally re-engineered the traditional stainless steel roller chain product in order to achieve unparalleled strength and wear performance. Now, incredibly, these chains possess ultimate strength ratings which challenge even the best carbon steel products. Wear performance has been increased by 35%-50% due to larger bearing areas and a unique labyrinth seal design.

MEGA CHAIN CONSTRUCTION



ALL PARTS ARE MADE FROM AISI 304 AUSTENETIC STAINLESS STEEL FOR EXCELLENT HEAT AND CORROSION RESISTANCE.

DUAL FUNCTION LINK PLATE CONSTRUCTION

Inside and outside link plates work together to improve strength and wear life in two important ways.

1. The "cap" portion of the outer plate engages the flanged portion of the inside plates under load to significantly improve both ultimate and fatigue strength. The improvement is so dramatic that these chains possess ultimate strength ratings which challenge even the best of the premium carbon steel brands.
2. The unique construction provides a labyrinth seal which helps to protect the pin/bushing wear area from abrasive particles and debris while allowing the penetration of lubricant. This feature, in combination with a larger pin/bushing bearing area, improves wear performance by 35%-50%.

COMPARE ULTIMATE STRENGTH RATINGS

AVERAGE TENSILE STRENGTH

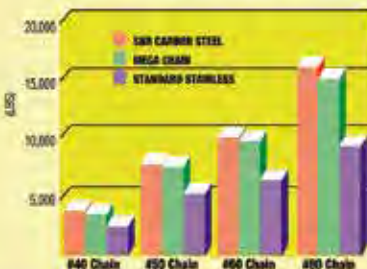

Stainless Steel MEGA CHAIN operates on standard ASME/ANSI sprockets. No special parts are required.

Double strand and double pitch chains are available from the factory.

Attachments are available for both the ANSI/ASME series and the double pitch series.

Outside plate "cap" engages the flanged inside plates increasing strength.

Labyrinth seal protects pin / bushing bearing area from contamination while allowing for lubrication.



ASME/ANSI Standard 304 Stainless Steel Mega Chain

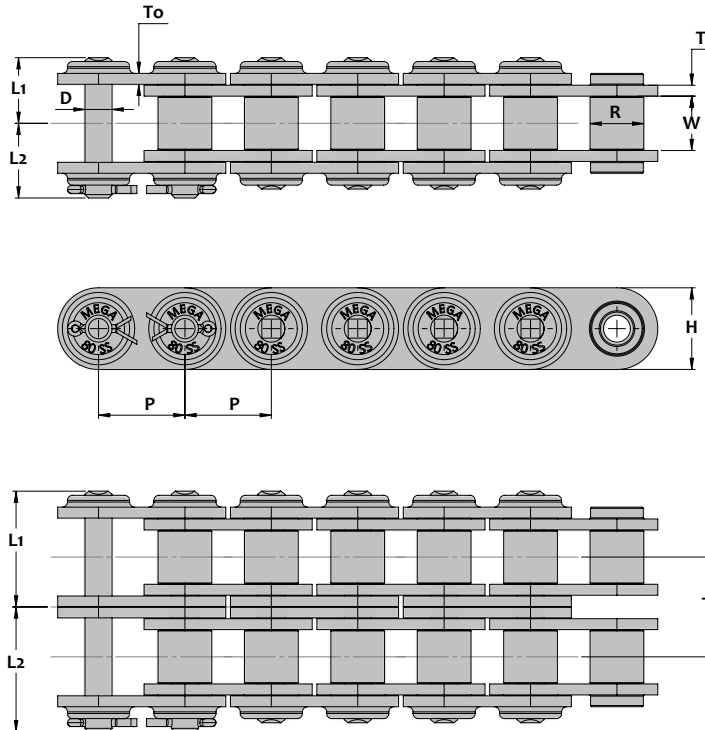

Chain Dimensions - Single Strand

MAXCO Chain Number	Units	Chain Pitch P	Roller		Pin			Side Plate		Trans. Pitch TP	Average Ultimate Strength Lbs Kg-f	Rated Working Load Lbs Kg-f	Average Chain Weight Lbs/ft Kg/m
			Dia	Inside Width	Dia	Length		Height	Thick.				
			R	W	D	Lr	Lc	H	Ti/To				
40SS-MEGA	inch	0.500	0.312	0.313	0.156	0.38	0.45	0.472	0.060	-	3,960	155	0.51
	mm	12.70	7.92	7.95	3.96	9.7	11.6	12.0	1.5	-	1,800	70	0.76
50SS-MEGA	inch	0.625	0.400	0.375	0.200	0.48	0.56	0.591	0.080	-	7,040	265	0.87
	mm	15.875	10.16	9.53	5.08	12.2	14.3	15.0	2.0	-	3,200	120	1.30
60SS-MEGA	inch	0.750	0.469	0.500	0.234	0.60	0.69	0.712	2.35	-	9,680	365	1.28
	mm	19.05	11.91	12.70	5.94	15.2	17.5	18.1	0.093	-	4,400	166	1.92
80SS-MEGA	inch	1.000	0.625	0.625	0.313	0.76	0.86	0.945	0.118	-	15,840	640	2.15
	mm	25.40	15.88	15.88	7.94	19.3	22.0	24.0	3.0	-	7,200	291	3.21

Chain Dimensions - Double Strand

40-2SS-MEGA	inch	0.500	0.312	0.313	0.156	0.66	0.74	0.472	0.060	0.567	6,600	240	0.95
	mm	12.70	7.92	7.95	3.96	16.9	18.8	12.0	1.5	14.4	3,000	109	1.42
50-2SS-MEGA	inch	0.625	0.400	0.375	0.200	0.83	0.92	0.591	0.080	0.713	10,560	420	1.64
	mm	15.875	10.16	9.53	5.08	21.2	23.3	15.0	2.0	18.1	4,800	191	2.45
60-2SS-MEGA	inch	0.750	0.469	0.500	0.234	1.05	1.14	0.712	2.35	0.898	14,960	615	2.39
	mm	19.05	11.91	12.70	5.94	26.6	28.9	18.1	0.093	22.8	6,800	280	3.56
80-2SS-MEGA	inch	1.000	0.625	0.625	0.313	1.34	1.44	0.945	0.118	1.154	23,760	1,080	3.87
	mm	25.40	15.88	15.88	7.94	34.0	36.6	24.0	3.0	29.3	10,800	491	5.76

ASME/ANSI Standard 304 Stainless Steel Mega Chain II

Mega Chain II utilizes two straight outside plates on each side rather than the concave formed outside plate. The ultimate strength of this series is slightly higher than standard Mega Chain.

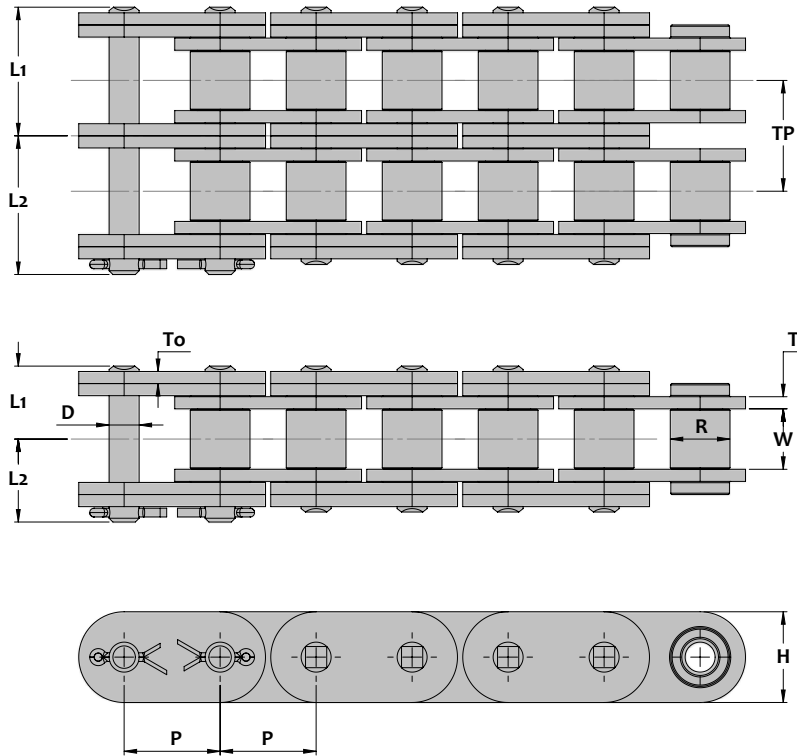

Chain Dimensions - Single Strand

MAXCO Chain Number	Units	Chain Pitch P	Roller		Pin			Side Plate		Trans. Pitch TP	Average Ultimate Strength Lbs Kg-f	Rated Working Load Lbs Kg-f	Average Chain Weight Lbs/ft Kg/m
			Dia R	Inside Width W	Dia D	Length L1 L2		Height H	Thick. Ti/To				
40SS-MEGA II	inch	0.500	0.312	0.313	0.156	0.38	0.45	0.472	0.060	-	4,400	155	0.60
	mm	12.70	7.92	7.95	3.96	9.7	11.6	12.0	1.5	-	2,000	70	0.90
50SS-MEGA II	inch	0.625	0.400	0.375	0.200	0.48	0.56	0.591	0.080	-	7,700	265	1.04
	mm	15.875	10.16	9.53	5.08	12.2	14.3	15.0	2.0	-	3,500	120	1.55
60SS-MEGA II	inch	0.750	0.469	0.500	0.234	0.60	0.69	0.712	2.35	-	10,560	365	1.54
	mm	19.05	11.91	12.70	5.94	15.2	17.5	18.1	0.093	-	4,800	166	2.29
80SS-MEGA II	inch	1.000	0.625	0.625	0.313	0.76	0.86	0.945	0.118	-	17,600	640	2.62
	mm	25.40	15.88	15.88	7.94	19.3	22.0	24.0	3.0	-	8,000	291	3.90

Chain Dimensions - Double Strand

40-2SS-MEGA II	inch	0.500	0.312	0.313	0.156	0.66	0.74	0.472	0.060	0.567	7,350	240	1.04
	mm	12.70	7.92	7.95	3.96	16.9	18.8	12.0	1.5	14.4	3,340	109	1.56
50-2SS-MEGA II	inch	0.625	0.400	0.375	0.200	0.83	0.92	0.591	0.080	0.713	11,550	420	1.81
	mm	15.875	10.16	9.53	5.08	21.2	23.3	15.0	2.0	18.1	5,250	191	2.70
60-2SS-MEGA II	inch	0.750	0.469	0.500	0.234	1.05	1.14	0.712	2.35	0.898	16,260	615	2.65
	mm	19.05	11.91	12.70	5.94	26.6	28.9	18.1	0.093	22.8	7,390	280	3.95
80-2SS-MEGA II	inch	1.000	0.625	0.625	0.313	1.34	1.44	0.945	0.118	1.154	26,400	1,080	4.33
	mm	25.40	15.88	15.88	7.94	34.0	36.6	24.0	3.0	29.3	12,000	491	6.46

ISO 606B British Standard 304 Stainless Steel Mega Chain II

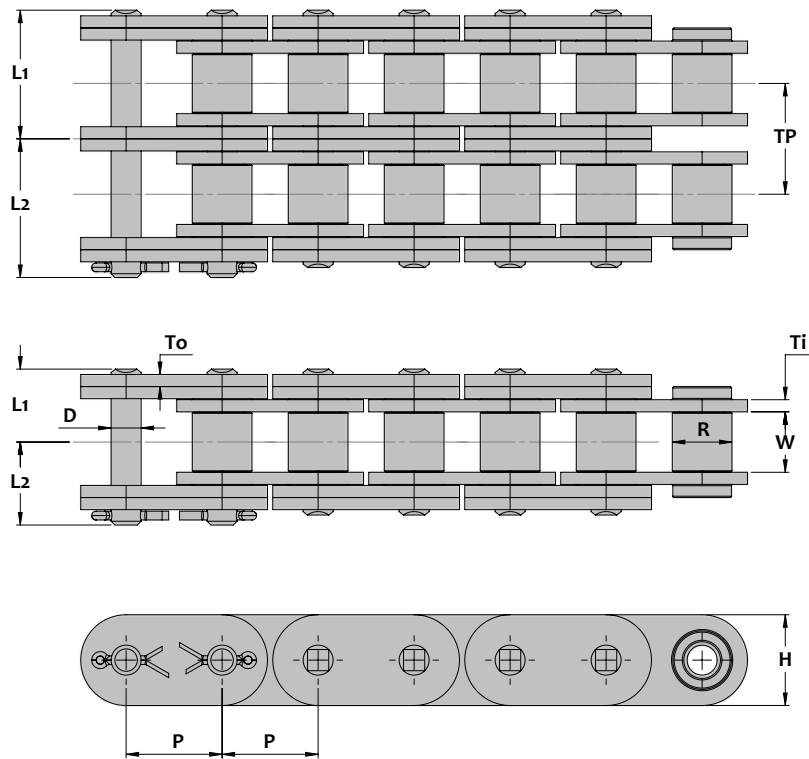

Chain Dimensions - Single Strand

MAXCO Chain Number	Units	Chain Pitch P	Roller		Pin			Side Plate		Trans. Pitch TP	Average Ultimate Strength Lbs Kg-f	Rated Working Load Lbs Kg-f	Average Chain Weight Lbs/ft Kg/m	
			Dia	Inside Width	Dia	Length		Height	Thickness					
			R	W	D	L1	L2	H	Ti					To
08BSS-MEGA II	inch	0.500	0.335	0.305	0.175	0.38	0.45	0.465	0.060		-	4,400	175	0.65
	mm	12.70	8.51	7.75	4.44	9.7	11.6	11.81	1.50		-	2,000	80	0.97
10BSS-MEGA II	inch	0.625	0.400	0.375	0.200	0.48	0.56	0.591	0.080		-	7,700	265	1.04
	mm	15.875	10.16	9.53	5.08	12.2	14.3	15.0	2.0		-	3,500	120	1.55
12BSS-MEGA II	inch	0.750	0.475	0.460	0.223	0.51	0.60	0.630	0.071		-	7,700	310	1.14
	mm	19.05	12.07	11.68	5.67	13.0	15.3	16.0	1.8		-	3,500	141	1.70
16BSS-MEGA II	inch	1.000	0.625	0.670	0.326	0.79	0.88	0.945	0.118	0.125	-	17,600	660	2.62
	mm	25.40	15.88	17.02	8.28	20.0	22.4	24.0	3.0	3.2	-	8,000	300	3.91

Chain Dimensions - Double Strand

08B-2SS-MEGA II	inch	0.500	0.335	0.305	0.175	0.66	0.73	0.465	0.060		0.548	7,350	275	1.17
	mm	12.70	8.51	7.75	4.44	16.7	18.5	11.81	1.50		13.92	3,340	125	1.75
10B-2SS-MEGA II	inch	0.625	0.400	0.375	0.200	0.83	0.92	0.591	0.080		0.713	11,550	420	1.73
	mm	15.875	10.16	9.53	5.08	21.2	23.3	15.0	2.0		18.1	5,250	191	2.58
12B-2SS-MEGA II	inch	0.750	0.475	0.460	0.223	0.90	0.98	0.630	0.071		0.766	11,550	515	1.99
	mm	19.05	12.07	11.68	5.67	22.8	25.0	16.0	1.8		19.46	5,250	234	2.96
16B-2SS-MEGA II	inch	1.000	0.625	0.670	0.326	1.41	1.51	0.945	0.118	0.125	1.255	26,400	1,120	4.88
	mm	25.40	15.88	17.02	8.28	35.9	38.3	24.0	3.0	3.2	31.88	12,000	509	7.27

Poly Steel (PS) Chain

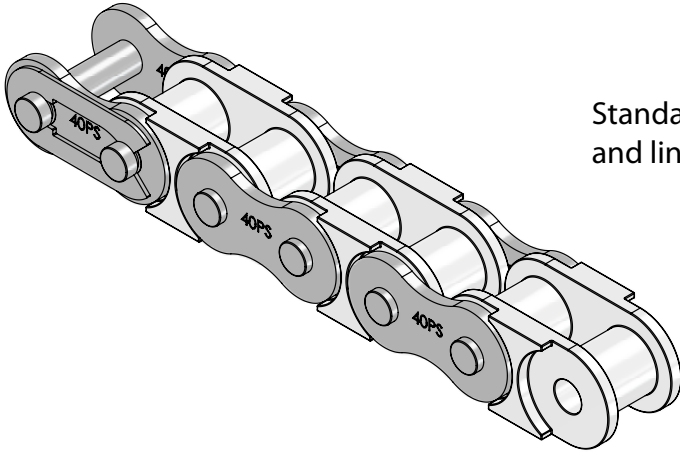

Standard PS (White) Version . . . 304 Stainless Steel pins and link plates - Engineered plastic (white) inner link

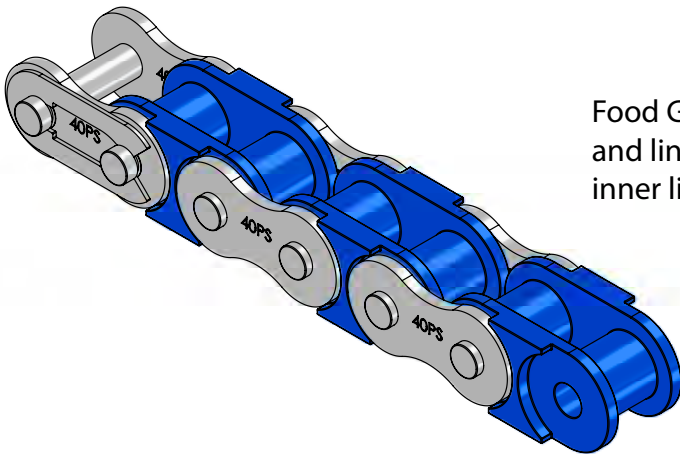

Food Grade PS(Blue) Version . . . 304 Stainless Steel pins and link plates - FDA approved Engineered plastic (blue) inner link

Standard Sprockets can be used however stainless steel or plastic sprockets are recommended in applications where rust can develop.

Allowable temperature range -4° F to 176° F (-20° C to 80° C)

Allowable PH range 4PH - 9PH

Maximum chain speed: 230 ft/min (70.1 m/min)

Maintenance Free Operation

Light Weight

Less Noise



Poly Steel (PS) Chain

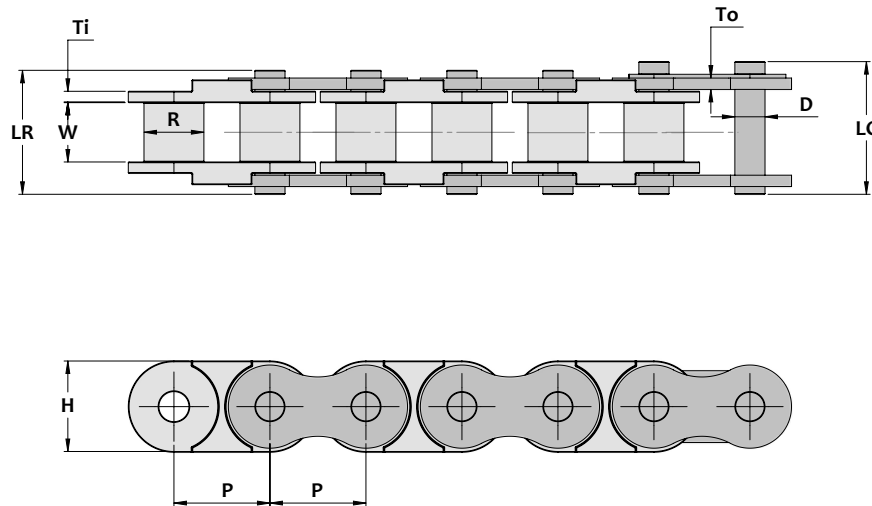

Chain Dimensions - ASME/ANSI Standard

MAXCO Chain Number	Units	Chain Pitch P	Roller		Pin			Side Plate			Rated Working Load Lbs Kg-f	Average Chain Weight Lbs/ft Kg/m
			Inside Width W	Dia. R	Dia. D	LR	LC	Height H	Thickness			
									Ti	To		
25PS	inch	0.250	0.122	0.130	0.091	0.35	0.39	0.237	0.050	0.030	18	0.06
	mm	6.35	3.10	3.30	2.31	8.9	9.9	6.02	1.3	0.75	8	0.10
35PS	inch	0.375	0.184	0.200	0.142	0.54	0.58	0.356	0.090	0.047	40	0.15
	mm	9.525	4.68	5.08	3.60	13.6	14.8	9.1	2.2	1.2	18	0.22
40PS	inch	0.500	0.309	0.312	0.157	0.65	0.69	0.475	0.060	0.060	100	0.26
	mm	12.70	7.85	7.92	3.98	16.4	17.6	12.1	1.5	1.5	45	0.39
50PS	inch	0.625	0.370	0.400	0.200	0.80	0.86	0.594	0.080	0.080	155	0.39
	mm	15.875	9.40	10.16	5.09	20.3	21.8	15.1	2.0	2.0	70	0.58
60PS	inch	0.750	0.495	0.469	0.235	0.99	1.05	0.713	0.094	0.094	200	0.55
	mm	19.05	12.57	11.91	5.96	25.1	26.7	18.1	2.4	2.4	91	0.82

Chain Dimensions - British Standard

06BPS	inch	0.375	0.225	0.250	0.129	0.48	0.54	0.339	0.050	0.040	45	0.15
	mm	9.525	5.72	6.35	3.28	12.2	13.8	8.6	1.3	1.0	20	0.22
08BPS	inch	0.500	0.305	0.335	0.175	0.65	0.69	0.465	0.063	0.050	105	0.25
	mm	12.70	7.75	8.51	4.45	16.4	17.7	11.8	1.6	1.5	48	0.37
10BPS	inch	0.625	0.380	0.400	0.200	0.76	0.81	0.580	0.065	0.065	120	0.34
	mm	15.875	9.65	10.16	5.08	19.2	20.7	14.7	1.65	1.65	55	0.51
12BPS	inch	0.750	0.460	0.475	0.225	0.87	0.93	0.635	0.070	0.070	155	0.46
	mm	19.05	11.68	12.07	5.72	22.2	23.7	16.1	1.8	1.8	70	0.68

Stainless Steel Corrosion Resistance Guide

Key

- 1 High Corrosion Resistance
- 2 Satisfactory Corrosion Resistance
- 3 Partially Corrosion Resistant
- 4 Not Recommended

Corrosive Agent	304SS Mega Chain	600SS	316SS	Corrosive Agent	304SS Mega Chain	600SS	316SS
Acetic Vapor	3	4	2	Calcium Chloride	2	3	1
Acetic Acid 100% 70°F (21°C)	1	2	1	Calcium Hypo-chloride	1	3	1
Acetic Acid 100% Boiling	2	3	1	Calcium Oxi-chloride	3	4	2
Acetic Acid 50% 70°F (21°C)	1	1	1	Calcium Sulfate	1	1	1
Acetic Acid 50% Boiling	2	3	1	Carbolic Acid	1	1	1
Acetone	1	1	1	Carbon Disulfide	1	1	1
Alcohol Methyl, Ethyl, Butyl, Propyl	1	1	1	Carbon Monoxide	1	2	1
Aluminum Acetate	1	1	1	Carbon Tetrachloride	1	1	1
Aluminum Chloride	3	3	2	Caustic Lime, Soda, Lye	1	1	1
Aluminum Potassium Sulfate 70°F (21°C)	1	1	1	Chlorinate Water 70°F (21°C)	1	1	1
Aluminum Potassium Sulfate - Boiling	2	3	1	Chlorine Gas Dry	3	4	2
Aluminum Sulfate 70°F (21°C)	1	1	1	Chlorine Gas Moist	4	4	3
Aluminum Sulfate Boiling	2	2	1	Chromic Acid 70°F (21°C)	1	1	1
Ammonia	1	1	1	Chromic Acid Boiling	3	4	1
Ammonium Bicarbonate	1	1	1	Citric Acid 70°F (21°C)	1	1	1
Ammonium Chloride 70°F (21°C)	1	1	1	Citric Acid Boiling	3	4	1
Ammonium Chloride Boiling	2	2	3	Calcium Hydroxide 20% Boiling	1	1	1
Ammonium Hydroxide	1	1	1	Coffee Boiling	1	1	1
Ammonium Nitrate	1	1	1	Cola Syrup	1	1	1
Ammonium Sulfate	1	1	1	Copper Acetate	1	1	1
Aniline	1	1	1	Copper Carbonate	1	1	1
Aniline Hydrochloride	3	3	2	Copper Chloride 70°F (21°C)	3	4	2
Baking Soda	1	1	1	Copper Chloride Boiling	4	4	3
Barium Carbonate	1	1	1	Epson Salts	1	1	1
Barium Chloride 70°F (21°C)	1	2	1	Ferric Chloride	2	3	1
Barium Chloride Hot	2	3	1	Ferric Hydroxide	1	1	1
Barium Nitrate	1	1	1	Ferric Nitrate	1	1	1
Barium Sulfate	1	1	1	Formalin 40%	1	1	1
Beer	1	1	1	Formic Acid	2	3	1
Beet Juice	1	1	1	Fruit Juices	1	2	1
Benzene	1	1	1	Gasoline	1	1	1
Benzine	1	1	1	Glue	1	1	1
Bleaching Powder	2	4	1	Glue Acidified	2	3	1
Blood (meat juices)	1	1	1	Glycerine, Glycerol	1	1	1
Borax	1	1	1	Gypsum	1	1	1
Boric Acid	1	1	1	Honey	1	1	1
Bromine	4	4	3	Hydrochloric Acid 70°F (21°C)	3	3	3
Butyric Acid	1	1	1	Hydrochloric Acid Boiling	4	4	4
Calcium Carbonate	1	1	1	Hydrochloric Acid Fumes	4	4	4

Stainless Steel Corrosion Resistance Guide

Key

- 1 High Corrosion Resistance
- 2 Satisfactory Corrosion Resistance
- 3 Partially Corrosion Resistant
- 4 Not Recommended

Corrosive Agent	304SS Mega Chain	600SS	316SS	Corrosive Agent	304SS Mega Chain	600SS	316SS
Hydrogen Peroxide 70°F (21°C) 30%	1	2	1	Potassium Bichromate	1	1	1
Hydrogen Sulfide Dry	1	1	1	Potassium Chlorate	1	1	1
Hydrogen Sulfide Moist	3	3	3	Potassium Chloride	2	3	1
Hydroxybenzene	1	1	1	Potassium Cyanide	1	1	1
Iodine Dry	1	1	1	Potassium Hydroxide 20%	1	1	1
Iodine Moist	4	4	3	Potassium Nitrate	1	1	1
Kerosene	1	1	1	Potassium Sulfate	1	1	1
Ketchup	1	1	1	Potassium Sulfide	1	1	1
Lactic Acid 150°F (65°C) 10%	3	3	1	Salt Ammoniac	2	3	1
Lactic Acid 70°F (21°C) 10%	1	1	1	Salt 150°F (65°C)	2	3	1
Lard	1	1	1	Salt 70°F (21°C)	1	2	1
Linseed Oil	1	1	1	Sea Water	2	3	1
Lye 70°F (21°C)	1	1	1	Sewage (sulfuric acid present)	2	3	1
Lye Boiling	2	3	1	Soap	1	1	1
Magnesium Chloride 70°F (21°C)	2	3	1	Soap and Water Solution	1	1	1
Magnesium Chloride Hot	3	4	2	Sodium Acetate	1	1	1
Malic Acid	1	1	1	Sodium Chloride 70°F (21°C) 5%	1	2	1
Manganese Chloride	1	1	1	Sodium Chloride Boiling 5%	2	3	1
Marsh Gas	1	1	1	Sodium Cyanide	1	1	1
Mayonnaise	1	2	1	Sodium Fluoride	2	3	1
Mercury	1	1	1	Sodium Hydroxide 25%	1	1	1
Milk	1	1	1	Sodium Hypo chloride (Bleach)	3	3	1
Nickel Chloride	2	3	1	Sodium Perchlorate	1	3	1
Nickel Sulfate	1	1	1	Sodium Peroxide	1	1	1
Nitric Acid 70°F (21°C)	1	1	1	Sodium Sulfide	2	3	1
Nitric Acid Concentrated Boiling	3	4	2	Sugar Solution	1	1	1
Nitric Acid Fuming	3	4	2	Sulfur Dioxide	1	3	1
Oil Crude	2	3	1	Sulfuric Acid 70°F (21°C) 5%	2	3	1
Oil Refined	1	1	1	Sulfuric Acid Boiling 5%	4	4	2
Oils (Mineral, Vegetable)	1	1	1	Sulfuric Acid Fuming	3	4	1
Oleic Acid	2	3	1	Sulfuric Acid Vapor	2	3	1
Paraffin	1	1	1	Turpentine	1	1	1
Petroleum	1	1	1	Varnish	1	1	1
Phenol	1	1	1	Vinegar	1	1	1
Phosphate	1	1	1	Whiskey	1	1	1
Phosphoric Acid	4	4	3	Wine	1	1	1
Phosphoric Acid 10% 70°F (21°C)	2	3	2	Wood Pulp	1	1	1
Phosphoric Acid 5% 70°F (21°C)	1	2	1	Zinc Chloride 70°F (21°C)	1	1	1
Picric Acid	1	1	1	Zinc Chloride Boiling	3	4	2

Maintenance Free Roller Chain - General Information

General Information

We offer one of the most extensive lines of specialty Maintenance Free roller chain products available to fit a wide array of special application needs. Designers can choose the series that best fits the particular needs of the application. These chains should be specified only when circumstances prohibit the use of lubricating oil since, in general, a well lubricated standard chain will offer longer life compared with a maintenance free chain. In some applications however lubrication isn't possible and so the use of a self lubricated or sealed roller chain is necessary.

General Properties of Maintenance Free Roller Chain Products

Product Group	Series Name	Features	Temperature Range	Max Chain Speeds
Sintered Type Oil Impregnated Bushings	Sintered Bushed (SL-Series) Chains	Oil impregnated powdered metal sintered bushings release oil to the chain joint due to the friction developed between the pin and bushing as the chain articulates over the sprocket teeth. These chains are rollerless and thus use thick sectioned powdered metal bushings which can hold a high volume of oil.	14°F - 140°F -10°C to 60°C	250 ft/min 75 m/min
	Freedom Series® PT Type Roller Chains	Oil impregnated powdered metal sintered bushings release oil to the chain joint due to the friction developed between the pin and bushing as the chain articulates over the sprocket teeth. These chains possess rollers to smooth the action over sprocket teeth. Roller link plates are one size thicker to increase strength. Side plates and pins have special coatings to prevent rust.	14°F - 140°F -10°C to 60°C	250 ft/min 75 m/min
	Freedom Series® C-Type Roller Chains	Same as above except that the side plates are all standard thickness. The strength of the CS Type chains is less than the PT Type but greater than the SL type. Attachments with standard dimensions can be used for this series and thus they are often used on small material handling conveyors.	14°F - 140°F -10°C to 60°C	250 ft/min 75 m/min
Sealed Type Roller Chains	O-Ring Chains	Specified on smaller pitch roller chains O-Ring chains utilize a rubber seal to keep lubricating grease in while preventing the penetration of dirt and other contaminants into the pin/bushing bearing area.	14°F - 140°F -10°C to 60°C	Depends on chain size. See specification table on page 99.
	Seal Guard® Roller Chains	Specified on larger pitch roller chains Seal Guard® chains utilize a stainless steel seal to keep lubricating grease in while preventing the penetration of dirt and other contaminants into the pin/bushing bearing area.	14°F - 140°F -10°C to 60°C Special Grease available to 300°F (150°C)	170 ft/min 50 m/min



ASME/ANSI Standard Self-Lube (SL) Series Roller Chain

Self-Lube (SL) chains feature oil impregnated sintered steel bushings, which release oil to the critical pin/bushing bearing area during operation and reabsorb it when the chain is at rest. The chains never need to be lubricated in service. They possess oversized bushings which will operate on standard sprockets. **CAUTION: The ultimate strength and working load ratings of SL-Series chains are less than their carbon steel counterparts. This fact should be considered when replacing standard carbon steel chains with SL-Series self lubricating chains.**

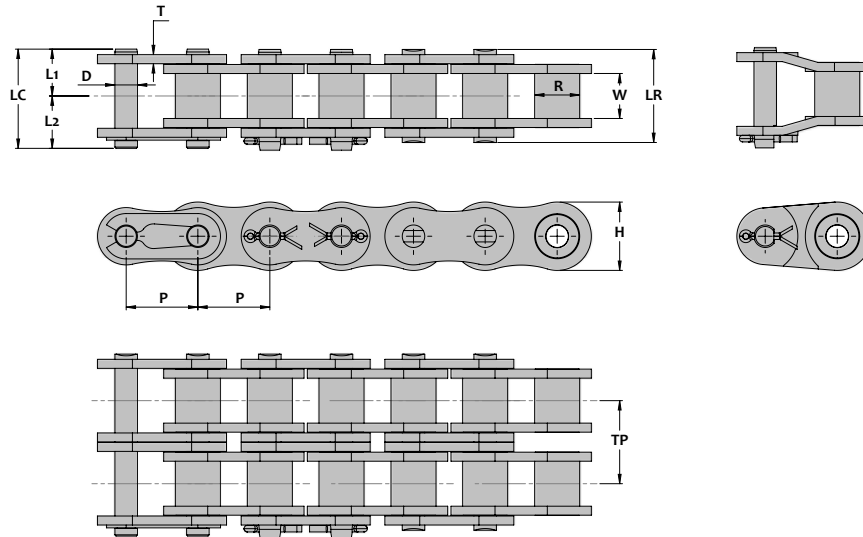

Chain Dimensions - Single Strand

MAXCO Chain Number	Units	Chain Pitch P	Bushing		Pin				Side Plate		Trans. Pitch TP	Average Ultimate Strength Lbs Kg-f	Rated Working Load Lbs Kg-f	Average Chain Weight Lbs/ft Kg/m	
			Dia.	Inside Width	Dia	Length			Height	Thick.					
			R	W	D	L1	L2	LR	LC	H					T
40SL	inch	0.500	0.312	0.313	0.156	0.33	0.38	0.65	0.70	0.461	0.060	-	2,860	660	0.42
	mm	12.70	7.92	7.95	3.96	8.3	9.6	16.6	17.9	11.7	1.5	-	1,300	300	0.63
50SL	inch	0.625	0.400	0.375	0.200	0.40	0.46	0.80	0.87	0.575	0.080	-	4,410	1,100	0.69
	mm	15.875	10.16	9.53	5.08	10.2	11.8	20.4	22.0	14.6	2.0	-	2,005	500	1.03
60SL	inch	0.750	0.469	0.500	0.234	0.50	0.56	1.00	1.06	0.689	0.094	-	6,390	1,540	0.98
	mm	19.05	11.91	12.70	5.95	12.8	14.1	25.5	26.9	17.5	2.4	-	2,905	700	1.46
80SL	inch	1.000	0.625	0.625	0.312	0.65	0.75	1.29	1.40	0.921	0.126	-	11,470	2,655	1.74
	mm	25.4	15.88	15.88	7.93	16.4	19.1	32.8	35.5	23.4	3.2	-	5,215	1,205	2.60
100SL	inch	1.250	0.75	0.750	0.375	0.78	0.92	1.55	1.69	1.154	0.157	-	18,520	3,980	2.54
	mm	31.75	19.05	19.05	9.53	19.7	23.3	39.4	43.0	29.3	4.0	-	8,420	1,810	3.79
120SL	inch	1.500	0.875	1.000	0.437	0.98	1.13	1.95	2.10	1.382	0.188	-	26,530	5,735	3.74
	mm	38.10	22.23	25.40	11.10	24.8	28.6	49.5	53.4	35.1	4.8	-	12,060	2,605	5.58

Chain Dimensions - Double Strand

40-2SL	inch	0.500	0.312	0.313	0.156	0.61	0.66	1.21	1.27	0.461	0.060	0.567	5,710	1,125	0.87
	mm	12.70	7.92	7.95	3.96	15.4	16.8	30.8	32.2	11.7	1.5	14.4	2,595	511	1.30
50-2SL	inch	0.625	0.400	0.375	0.200	0.76	0.82	1.51	1.57	0.575	0.080	0.712	8,810	1,870	1.41
	mm	15.875	10.16	9.53	5.08	19.2	20.8	38.4	40.0	14.6	2.0	18.08	4,005	850	2.10
60-2SL	inch	0.750	0.469	0.500	0.234	0.94	1.01	1.90	1.96	0.689	0.094	0.898	12,770	2,610	2.01
	mm	19.05	11.91	12.70	5.95	24.0	25.7	48.2	49.7	17.5	2.4	22.8	5,805	1,185	3.00
80-2SL	inch	1.000	0.625	0.625	0.312	1.21	1.33	2.43	2.54	0.921	0.126	1.154	22,930	4,500	3.49
	mm	25.4	15.88	15.88	7.93	30.8	33.7	61.6	64.5	23.4	3.2	29.3	10,425	2,045	5.20

ASME/ANSI Double Pitch Self-Lube (SL) Series Roller Chain

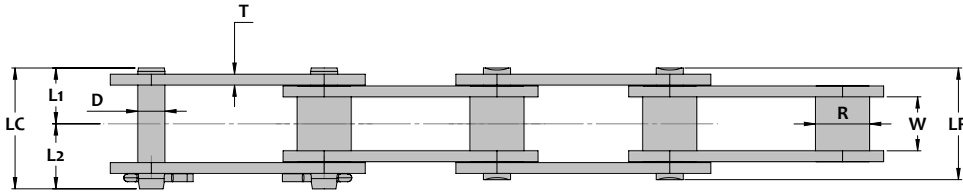

Standard Roller

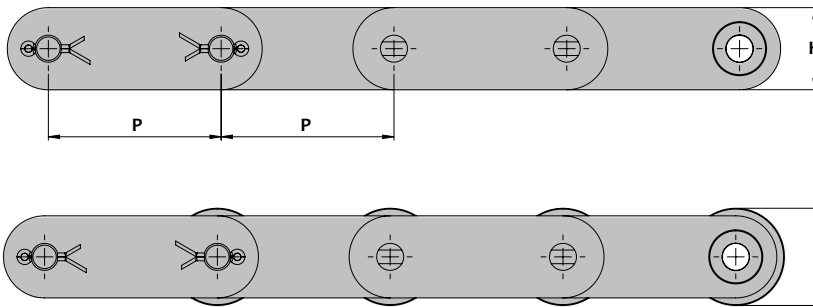

Large Roller

Chain Dimensions - Standard Roller

MAXCO Chain Number	Units	Chain Pitch P	Roller		Pin					Side Plate		Average Ultimate Strength Lbs Kg-f	Rated Working Load Lbs Kg-f	Average Chain Weight Lbs/ft Kg/m
			Dia	Inside Width	Dia	Length				Height	Thick.			
			R	W	D	L1	L2	LR	LC	H	T			
C2040SL	inch	1.000	0.312	0.313	0.156	0.32	0.41	0.65	0.73	0.475	0.060	2,860	660	0.32
	mm	25.40	7.92	7.95	3.96	8.2	10.3	16.4	18.5	12.06	1.5	1,300	300	0.48
C2050SL	inch	1.250	0.400	0.375	0.200	0.40	0.49	0.80	0.89	0.594	0.080	4,410	1,100	0.55
	mm	31.75	10.16	9.53	5.08	10.2	12.4	20.3	22.6	15.1	2.0	2,005	500	0.82
C2060SL	inch	1.500	0.469	0.500	0.234	0.50	0.56	1.00	1.06	0.712	0.094	6,390	1,540	0.80
	mm	38.10	11.91	12.70	5.95	12.8	14.1	25.5	26.9	18.1	2.4	2,905	700	1.20
C2080SL	inch	2.000	0.625	0.625	0.312	0.65	0.75	1.29	1.40	0.950	0.126	11,470	2,655	1.33
	mm	50.80	15.88	15.88	7.93	16.4	19.1	32.8	35.5	24.1	3.2	5,215	1,205	1.99

Chain Dimensions - Larger Roller

C2042SL	inch	1.000	0.625	0.313	0.156	0.32	0.41	0.65	0.73	0.475	0.060	2,860	660	0.55
	mm	25.40	15.88	7.95	3.96	8.2	10.3	16.4	18.5	12.06	1.5	1,300	300	0.82
C2052SL	inch	1.250	0.750	0.375	0.200	0.40	0.49	0.80	0.89	0.594	0.080	4,410	1,100	0.84
	mm	31.75	19.05	9.53	5.08	10.2	12.4	20.3	22.6	15.1	2.0	2,005	500	1.26
C2062SL	inch	1.500	0.875	0.500	0.234	0.50	0.56	1.00	1.06	0.712	0.094	6,390	1,540	1.19
	mm	38.10	22.23	12.70	5.95	12.8	14.1	25.5	26.9	18.1	2.4	2,905	700	1.78
C2082SL	inch	2.000	1.125	0.625	0.312	0.65	0.75	1.29	1.40	0.950	0.126	11,470	2,655	2.03
	mm	50.80	28.58	15.88	7.93	16.4	19.1	32.8	35.5	24.1	3.2	5,215	1,205	3.03

ASME/ANSI Standard Freedom Series® PT-Type Roller Chain

Freedom Series® Self-Lubricating Roller Chains offer premium performance and value in a sintered bushing maintenance free product. These chains feature the addition of rollers to reduce friction and smooth the action over sprockets, specially coated pins and link plates for rust prevention and special part treatments for improved wear performance. The PT-Type chains are used mainly for power transmission applications. Side plates of the roller links are one size thicker than standard providing chain strength that is similar to standard roller chains. This allows for direct replacement for most moderate speed drive applications. The chains will operate on standard ASME/ANSI sprockets. (Maximum operating speed of 160 FPM)

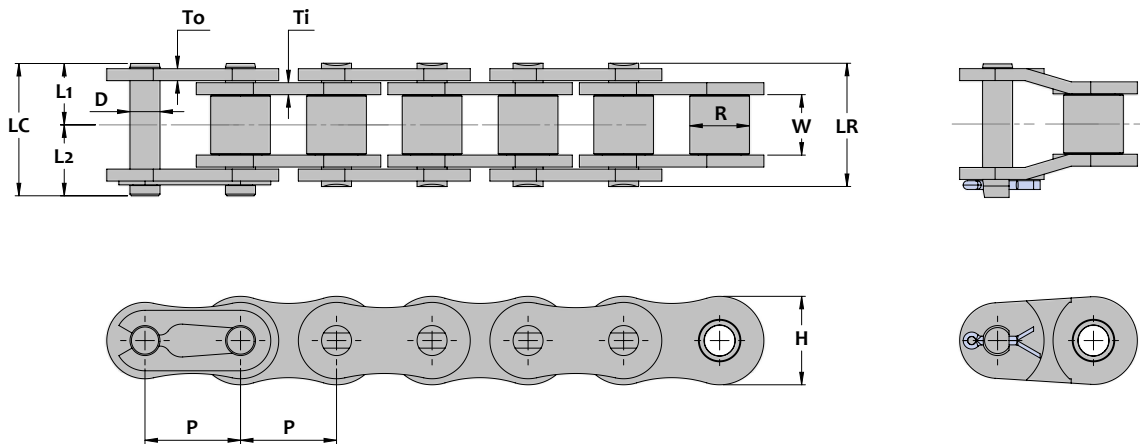

Chain Dimensions

MAXCO Chain Number	Units	Chain Pitch P	Roller		Pin					Side Plate			Average Ultimate Strength Lbs Kg-f	Rated Working Load Lbs Kg-f	Average Chain Weight Lbs/ft Kg/m
			Dia.	Inside Width	Dia	Length				Height	Thickness				
			R	W	D	L1	L2	LR	LC	H	Ti	To			
40FS	inch	0.500	0.312	0.313	0.156	0.33	0.39	0.65	0.71	0.461	0.080	0.060	4,300	815	0.47
	mm	12.70	7.92	7.95	3.96	8.3	9.8	16.6	18.1	11.7	2.0	1.5	1,955	370	0.70
50FS	inch	0.625	0.400	0.375	0.200	0.41	0.47	0.81	0.88	0.575	0.094	0.080	7,200	1,410	0.74
	mm	15.875	10.16	9.53	5.08	10.3	12.0	20.6	22.3	14.6	2.4	2.0	3,275	641	1.10
60FS	inch	0.750	0.469	0.500	0.234	0.51	0.57	1.02	1.08	0.689	0.125	0.094	10,000	1,940	1.14
	mm	19.05	11.91	12.70	5.95	13.0	14.5	26.0	27.5	17.5	3.2	2.4	4,545	882	1.70
80FS	inch	1.000	0.625	0.625	0.312	0.65	0.76	1.30	1.41	0.921	0.157	0.126	17,650	3,300	1.81
	mm	25.4	15.88	15.88	7.93	16.5	19.4	33.0	35.9	23.4	4.0	3.2	8,025	1,500	2.70
100FS	inch	1.250	0.75	0.750	0.375	0.78	0.91	1.57	1.70	1.154	0.189	0.157	26,500	5,080	2.88
	mm	31.75	19.05	19.05	9.53	19.9	23.2	39.8	43.1	29.3	4.8	4.0	12,045	2,310	4.30
120FS	inch	1.500	0.875	1.000	0.437	0.98	1.11	1.96	2.09	1.382	0.220	0.188	39,000	6,830	4.02
	mm	38.10	22.23	25.40	11.10	24.9	28.3	49.8	53.2	35.1	5.6	4.8	17,725	3,105	6.00

ISO 606B British Standard Freedom Series® C-Type Roller Chain

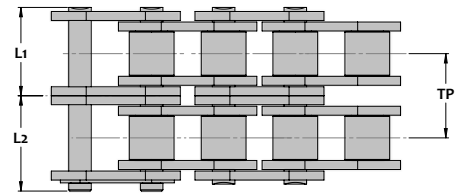
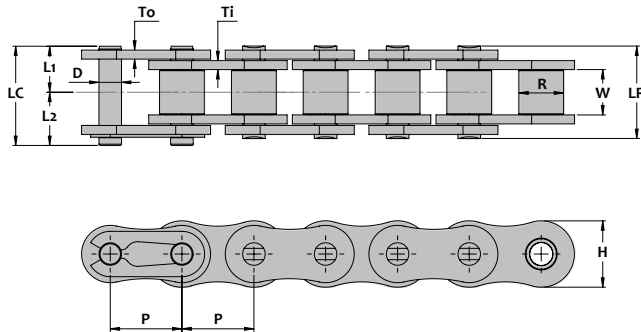

Chain Dimensions - Single Strand

MAXCO Chain Number	Units	Chain Pitch P	Roller			Pin				Side Plate			Trans. Pitch TP	Average Ultimate Strength Lbs Kg-f	Rated Working Load Lbs Kg-f	Average Chain Weight Lbs/ft Kg/m
			Inside Width W	Dia. R	Dia. D	Length				Height H	Thickness					
						L1	L2	LR	LC	To	Ti					
08BFS-C	inch	0.500	0.305	0.335	0.175	0.33	0.39	0.66	0.72	0.465	0.060		-	3,780	650	0.40
	mm	12.70	7.75	8.51	4.45	8.4	9.8	16.7	18.2	11.8	1.5		-	1,720	295	0.60
10BFS-C	inch	0.625	0.380	0.400	0.200	0.37	0.44	0.75	0.81	0.579	0.065		-	5,530	990	0.60
	mm	15.875	9.65	10.16	5.08	9.5	11.2	19.0	20.7	14.7	1.65		-	2,515	450	0.90
12BFS-C	inch	0.750	0.460	0.475	0.225	0.43	0.50	0.87	0.93	0.634	0.070		-	7,280	1,420	0.74
	mm	19.05	11.68	12.07	5.7	11.0	12.6	22.0	23.6	16.1	1.8		-	3,310	645	1.10
16BFS-C	inch	1.000	0.670	0.625	0.325	0.69	0.81	1.38	1.50	0.827	0.126	0.157	-	16,770	2,740	1.74
	mm	25.40	17.02	15.88	8.26	17.6	20.6	35.1	38.2	21.0	3.2	4.0	-	7,625	1,245	2.60
20BFS-C	inch	1.250	0.770	0.750	0.400	0.79	0.94	1.58	1.73	1.039	0.138	0.177	-	28,840	4,290	2.55
	mm	31.75	19.56	19.05	10.16	20.1	23.9	40.2	44.0	26.4	3.5	4.5	-	13,110	1,950	3.80

Chain Dimensions - Double Strand

08B-2FS-C	inch	0.500	0.305	0.335	0.175	0.60	0.65	1.20	1.26	0.465	0.060		0.548	7,550	1,120	0.87
	mm	12.70	7.75	8.51	4.45	15.3	16.6	30.6	31.9	11.8	1.5		13.92	3,430	509	1.30
10B-2FS-C	inch	0.625	0.380	0.400	0.200	0.70	0.77	1.40	1.47	0.579	0.065		0.653	11,060	1,690	1.21
	mm	15.875	9.65	10.16	5.08	17.8	19.5	35.6	37.3	14.7	1.65		16.59	5,025	768	1.80
12B-2FS-C	inch	0.750	0.460	0.475	0.225	0.82	0.88	1.64	1.70	0.634	0.070		0.766	14,570	2,430	1.94
	mm	19.05	11.68	12.07	5.7	20.8	22.3	41.6	43.1	16.1	1.8		19.46	6,625	1,105	2.90
16B-2FS-c	inch	1.000	0.670	0.625	0.325	1.32	1.44	2.64	2.76	0.827	0.126	0.157	1.255	33,540	4,650	3.42
	mm	25.40	17.02	15.88	8.26	33.6	36.5	67.2	70.1	21.0	3.2	4.0	31.88	15,245	2,115	5.10
20B-2FS-C	inch	1.250	0.770	0.750	0.400	1.51	1.66	3.02	3.17	1.039	0.138	0.177	1.435	57,690	7,280	4.90
	mm	31.75	19.56	19.05	10.16	38.4	42.2	76.8	80.6	26.4	3.5	4.5	36.45	26,225	3,310	7.30

ASME/ANSI Double Pitch Freedom Series® C-Type Roller Chain

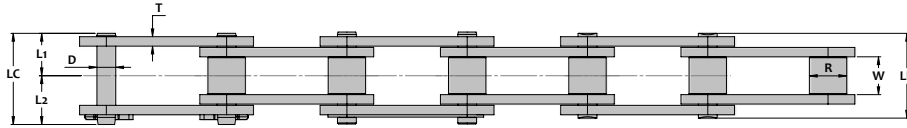

Standard Roller

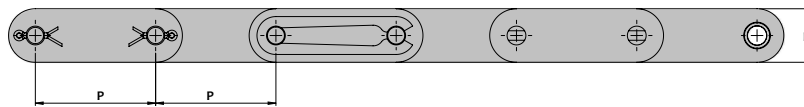

Large Roller

Chain Dimensions - Standard Roller

MAXCO Chain Number	Units	Chain Pitch P	Roller		Pin					Side Plate		Average Ultimate Strength Lbs Kg-f	Rated Working Load Lbs Kg-f	Average Chain Weight Lbs/ft Kg/m
			Dia R	Inside Width W	Dia D	Length				Height H	Thick. T			
						L1	L2	LR	LC					
C2040FS-C	inch	1.000	0.312	0.313	0.156	0.32	0.41	0.65	0.73	0.475	0.060	3,530	595	0.34
	mm	25.40	7.92	7.95	3.96	8.2	10.3	16.4	18.5	12.06	1.5	1,605	270	0.50
C2050FS-C	inch	1.250	0.400	0.375	0.200	0.40	0.49	0.80	0.89	0.594	0.080	5,730	970	0.54
	mm	31.75	10.16	9.53	5.08	10.2	12.4	20.3	22.6	15.1	2.0	2,605	441	0.80
C2060HFS-C	inch	1.500	0.469	0.500	0.234	0.57	0.67	1.13	1.23	0.712	0.125	8,390	1,410	0.94
	mm	38.10	11.91	12.70	5.95	14.4	16.9	28.8	31.3	18.1	3.2	3,815	641	1.40
C2080HFS-C	inch	2.000	0.625	0.625	0.312	0.71	0.89	1.43	1.60	0.950	0.156	14,320	2,410	1.61
	mm	50.80	15.88	15.88	7.93	18.2	22.6	36.3	40.7	24.1	4.0	6,510	1,095	2.40

Chain Dimensions - Larger Roller

C2042FS-C	inch	1.000	0.625	0.313	0.156	0.32	0.41	0.65	0.73	0.475	0.060	3,530	595	0.67
	mm	25.40	15.88	7.95	3.96	8.2	10.3	16.4	18.5	12.06	1.5	1,605	270	1.00
C2052FS-C	inch	1.250	0.750	0.375	0.200	0.40	0.49	0.80	0.89	0.594	0.080	5,730	970	1.07
	mm	31.75	19.05	9.53	5.08	10.2	12.4	20.3	22.6	15.1	2.0	2,605	441	1.60
C2062HFS-C	inch	1.500	0.875	0.500	0.234	0.57	0.67	1.13	1.23	0.712	0.125	8,390	1,410	1.88
	mm	38.10	22.23	12.70	5.95	14.4	16.9	28.8	31.3	18.1	3.2	3,815	641	2.80
C2082HFS-C	inch	2.000	1.125	0.625	0.312	0.71	0.89	1.43	1.60	0.950	0.156	14,320	2,410	3.08
	mm	50.80	28.58	15.88	7.93	18.2	22.6	36.3	40.7	24.1	4.0	6,510	1,095	4.6

ASME/ANSI Standard O-Ring Type Roller Chain

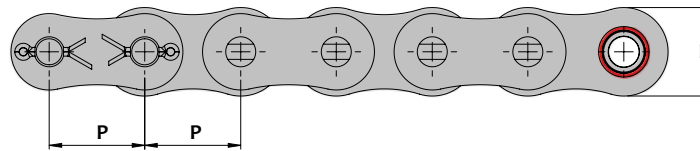
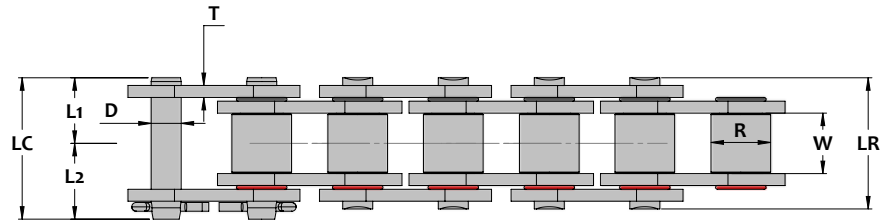
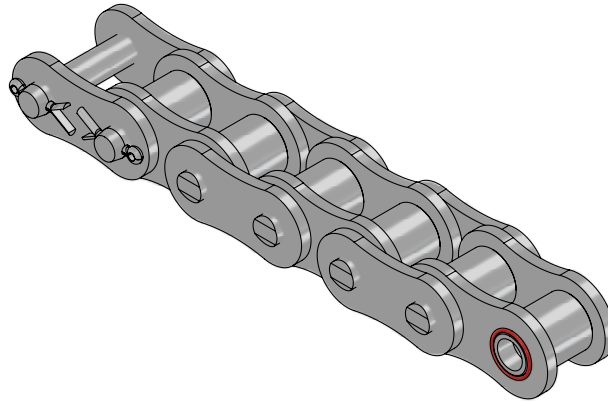

Chain Dimensions

MAXCO Chain Number	Units	Chain Pitch P	Roller		Pin			Side Plate		Maximum Chain Speed ft/min m/min	Average Ultimate Strength Lbs Kg-f	Average Chain Weight Lbs/ft Kg/m
			Dia.	Inside Width	Dia	Length		Height	Thick.			
			R	W	D	L1	L2	H	T			
40 O-Ring	inch	0.500	0.312	0.313	0.156	0.36	0.41	0.476	0.060	1,300	4,180	0.67
	mm	12.70	7.92	7.95	3.96	9.1	10.5	12.1	1.5	395	1,900	1.00
50 O-Ring	inch	0.625	0.400	0.375	0.200	0.46	0.48	0.594	0.080	1,000	6,930	1.08
	mm	15.875	10.16	9.53	5.08	11.6	12.1	15.1	2.0	305	3,150	1.61
60 O-Ring	inch	0.750	0.469	0.500	0.234	0.55	0.59	0.713	0.094	850	10,340	1.61
	mm	19.05	11.91	12.70	5.95	13.9	14.9	18.1	2.4	260	4,700	2.40
80 O-Ring	inch	1.000	0.625	0.625	0.312	0.69	0.77	0.949	0.125	650	17,930	2.76
	mm	25.4	15.88	15.88	7.93	17.6	19.5	24.1	3.2	200	8,150	4.12

Maintenance Free Operation now possible for Heavy Duty Roller Chain Drives

Newly developed, patent pending; SEAL GUARD™ Roller Chains from SENQCIA extend the benefits of maintenance free operation to larger pitch heavy duty roller chain drives.

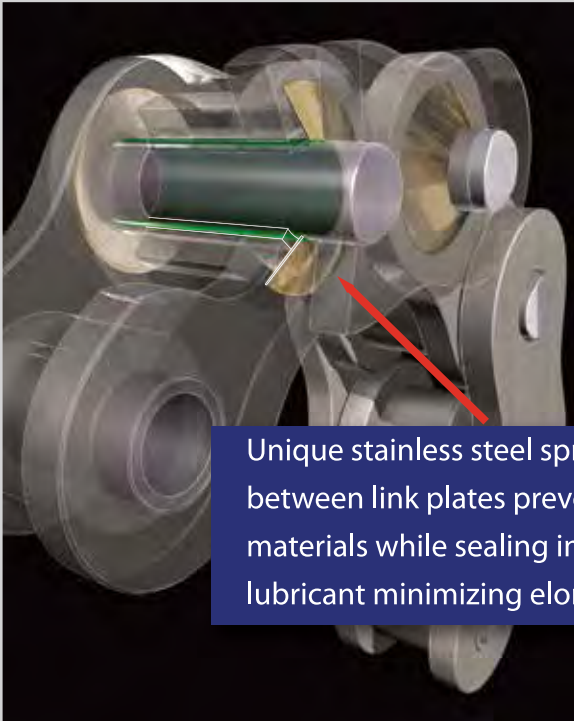

Unique stainless steel spring type contact seals fitted between link plates prevent penetration of abrasive materials while sealing in high quality bearing lubricant minimizing elongation due to chain wear

Construction, mining, shot blast equipment, as well as a broad range of heavy duty roller chain applications can now utilize large pitch roller chain - Sizes 60 (3/4" pitch) thru 240 (3" pitch) and enjoy the significant benefits of maintenance free operation. The unique stainless steel contact seals, installed between the link plates, retains a high quality bearing grease inside the chain joint, keeping out damaging abrasives such as grit and other debris that decrease chain life.

These chains never require continuous lubrication, possess the same strength and working load capability as standard duty roller chain and will operate over a wider range of temperatures and speeds. Stainless steel seals are more durable than conventional O-Rings and the lubrication benefits of the internal bearing grease offer superior lubrication over other similar types of maintenance free chains.



SEAL GUARD™ Roller Chains are available with a variety of corrosion resistant coatings. Our unique Inspire Series™ stainless steel blast coating is standard finish, optional black oxide or our Perfect Coat Plus® surface treatments offer significant added protection against external chain corrosion.



ASME/ANSI Standard Seal Guard® Roller Chain

Note: Maximum adjustable operating speed of 160 FPM

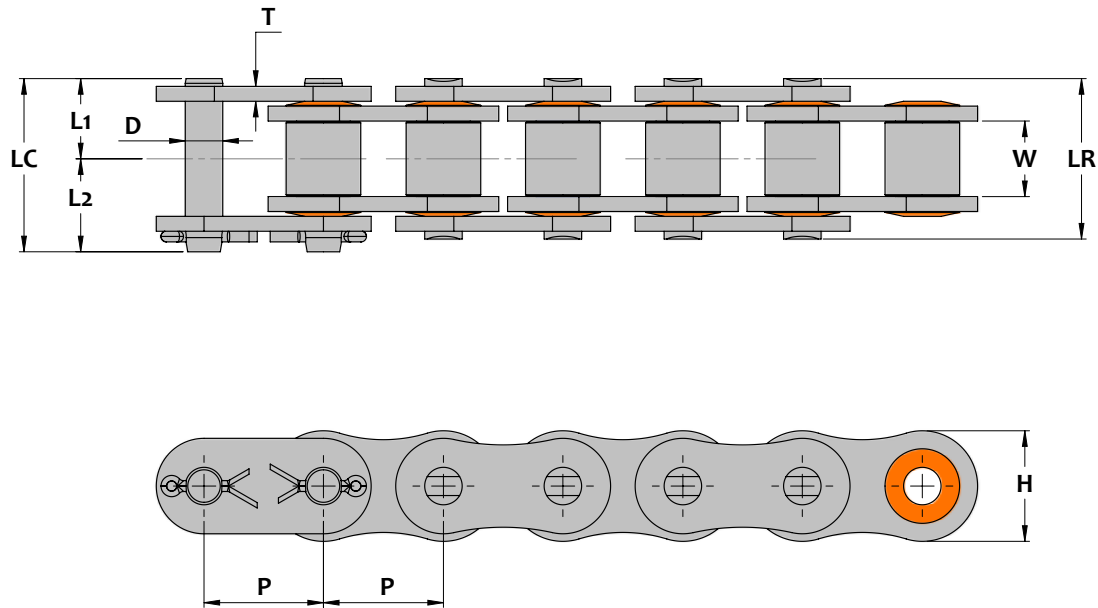

Chain Dimensions

MAXCO Chain Number	Units	Chain Pitch P	Roller		Pin					Side Plate		Average Ultimate Strength Lbs Kg-f	Rated Working Load Lbs Kg-f	Average Chain Weight Lbs/ft Kg/m
			Dia	Inside Width	Dia	Length				Height	Thick.			
			R	W	D	L1	L2	LR	LC	H	T			
80SG	inch	1.000	0.625	0.625	0.312	0.69	0.79	1.37	1.48	0.949	0.126	17,650	4,140	1.74
	mm	25.40	15.88	15.88	7.92	17.4	20.1	34.8	37.5	24.1	3.2	8,025	1,880	2.60
100SG	inch	1.250	0.750	0.750	0.375	0.82	0.96	1.64	1.78	1.185	0.157	26,500	6,360	2.62
	mm	31.75	19.05	19.05	9.53	20.8	24.4	41.6	45.2	30.1	4.0	12,045	2,890	3.90
120SG	inch	1.500	0.875	1.000	0.437	1.02	1.17	2.04	2.19	1.425	0.188	39,000	8,540	3.89
	mm	38.10	22.23	25.40	11.10	25.9	29.8	51.8	55.7	36.2	4.8	17,725	3,880	5.80
140SG	inch	1.750	1.000	1.000	0.500	1.11	1.28	2.21	2.38	1.661	0.220	48,600	11,310	5.03
	mm	44.45	25.40	25.40	12.70	28.1	32.4	56.2	60.5	42.2	5.6	22,090	5,140	7.50
160SG	inch	2.000	1.125	1.250	0.562	1.31	1.48	2.62	2.80	1.898	0.250	63,000	14,910	6.57
	mm	50.80	28.58	31.75	14.27	33.3	37.7	66.6	71.0	48.2	6.4	28,635	6,775	9.80
180SG	inch	2.250	1.406	1.406	0.687	1.52	1.71	3.04	3.23	2.067	0.283	81,500	15,870	9.10
	mm	57.15	35.7	35.7	17.45	38.6	43.4	77.2	82.0	52.5	7.2	37,045	7,215	13.57
200SG	inch	2.500	1.562	1.500	0.781	1.61	1.95	3.23	3.56	2.374	0.315	105,000	18,500	11.33
	mm	63.50	39.67	38.10	19.84	41.0	49.5	82.0	90.5	60.3	8.0	47,725	8,410	16.90
240SG	inch	3.000	1.875	1.875	0.936	1.97	2.27	3.94	4.24	2.850	0.374	152,200	25,360	15.83
	mm	76.20	47.63	47.63	23.78	50.0	57.7	100.0	107.7	72.4	9.5	69,180	11,525	23.60

ASME/ANSI Standard Carbon Steel Hollow Pin Chain

ASME/ANSI Hollow Pin chains offer versatility in conveyor design by allowing for the insertion of through rods or other attachments through the hollow pins. Our solid cold forged solid (i.e. seamless) hollow pins provide for superior wear performance. These chains are also available in Nickel Plate or Perfect Coat Plus® if corrosion resistance is required.

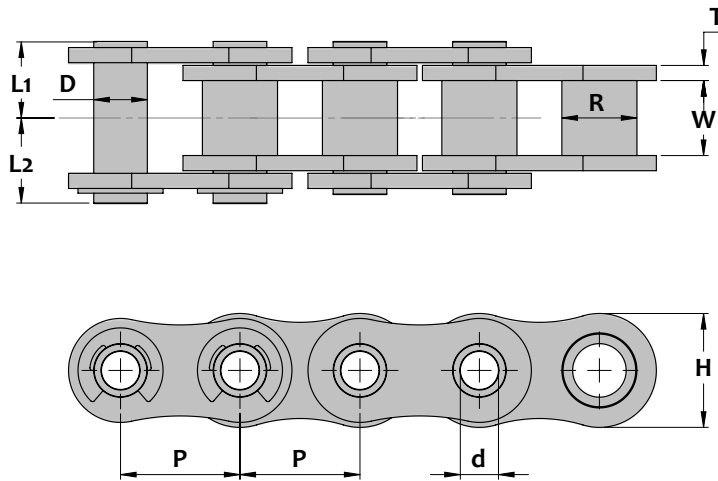
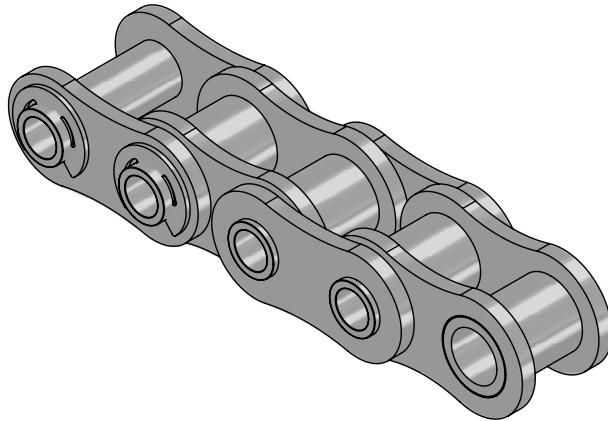

Chain Dimensions

MAXCO Chain Number	Units	Chain Pitch P	Bushing		Pin				Side Plate		Average Ultimate Strength Lbs Kg-f	Rated Working Load Lbs Kg-f	Average Chain Weight Lbs/ft Kg/m
			Dia.	Inside Width	Diameter		Length		Height	Thick.			
			R	W	D	d	L1	L2	H	T			
40HP	inch	0.500	0.312	0.313	0.222	0.159	0.33	0.36	0.472	0.060	2,860	400	0.39
	mm	12.70	7.92	7.95	5.63	4.03	8.4	9.2	12.0	1.5	1,300	182	0.58
50HP	inch	0.625	0.400	0.375	0.279	0.202	0.40	0.44	0.591	0.080	4,410	705	0.67
	mm	15.875	10.16	9.53	7.09	5.13	10.1	11.2	15.0	2.0	2,005	320	0.97
60HP	inch	0.750	0.469	0.500	0.326	0.238	0.51	0.56	0.713	0.094	6,390	950	0.98
	mm	19.05	11.91	12.70	8.29	6.04	13.0	14.2	18.1	2.4	2,905	432	1.46
80HP	inch	1.000	0.625	0.625	0.446	0.318	0.64	0.71	0.949	0.126	11,470	1,720	1.66
	mm	25.4	15.88	15.88	11.34	8.08	16.2	18.1	24.1	3.2	5,215	782	2.47

ASME/ANSI Double Pitch Carbon Steel Hollow Pin Chain

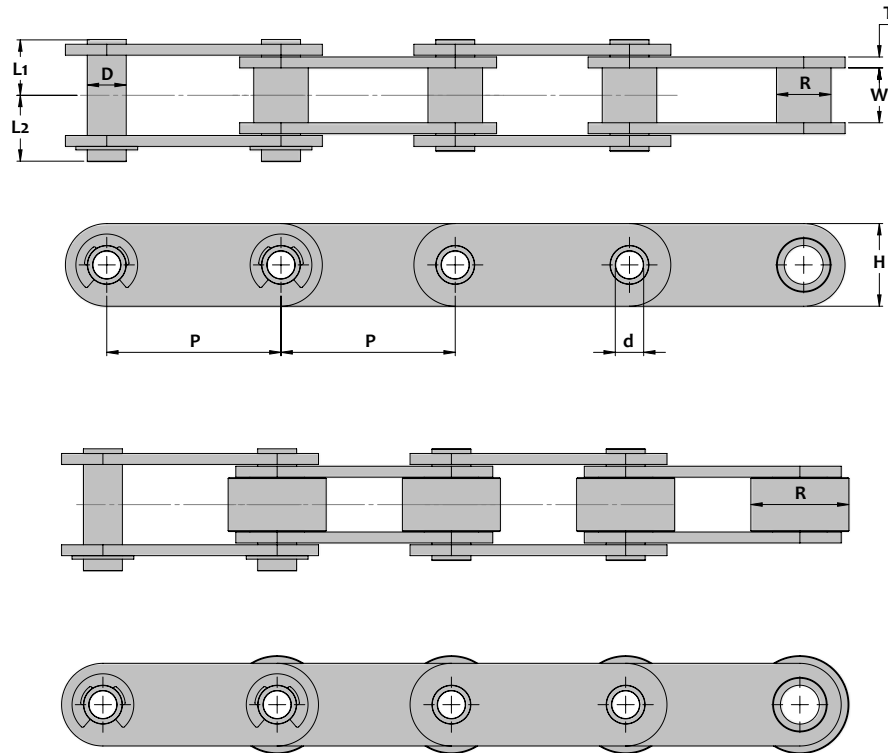

Chain Dimensions - Standard Roller

MAXCO Chain Number	Units	Chain Pitch P	Bushing/Roller		Pin				Side Plate		Average Ultimate Strength Lbs Kg-f	Rated Working Load Lbs Kg-f	Average Chain Weight Lbs/ft Kg/m
			Dia	Inside Width	Diameter		Length		Height	Thick.			
			R	W	D	d	L1	L2	H	T			
C2040HP	inch	1.000	0.312	0.313	0.222	0.159	0.33	0.36	0.472	0.060	2,860	400	0.31
	mm	25.40	7.92	7.95	5.63	4.03	8.4	9.2	12.0	1.5	1,300	182	0.46
C2050HP	inch	1.250	0.400	0.375	0.279	0.202	0.40	0.44	0.591	0.080	4,410	705	0.51
	mm	31.75	10.16	9.53	7.09	5.13	10.1	11.2	15.0	2.0	2,005	320	0.76
C2060HP	inch	1.500	0.469	0.500	0.326	0.238	0.51	0.56	0.713	0.094	6,390	950	0.75
	mm	38.10	11.91	12.70	8.29	6.04	13.0	14.2	18.1	2.4	2,905	432	1.12
C2080HP	inch	2.000	0.625	0.625	0.446	0.318	0.64	0.71	0.949	0.126	11,470	1,720	1.33
	mm	50.80	15.88	15.88	11.34	8.08	16.2	18.1	24.1	3.2	5,215	782	1.98

Chain Dimensions - Large Roller

C2042HP	inch	1.000	0.625	0.313	0.222	0.159	0.33	0.36	0.472	0.060	2,860	400	0.54
	mm	25.40	15.88	7.95	5.63	4.03	8.4	9.2	12.0	1.5	1,300	182	0.81
C2052HP	inch	1.250	0.750	0.375	0.279	0.202	0.40	0.44	0.591	0.080	4,410	705	0.84
	mm	31.75	19.05	9.53	7.09	5.13	10.1	11.2	15.0	2.0	2,005	320	1.25
C2062HP	inch	1.500	0.875	0.500	0.326	0.238	0.51	0.56	0.713	0.094	6,390	950	1.20
	mm	38.10	22.23	12.70	8.29	6.04	13.0	14.2	18.1	2.4	2,905	432	1.79
C2082HP	inch	2.000	1.125	0.625	0.446	0.318	0.64	0.71	0.949	0.126	11,470	1,720	2.13
	mm	50.80	28.58	15.88	11.34	8.08	16.2	18.1	24.1	3.2	5,215	782	3.17

ASME/ANSI Standard Stainless Steel Hollow Pin Chain

ASME/ANSI Hollow Pin chains are made from AISI Type 304 stainless steel for excellent corrosion and temperature resistance. These chains are often found in many food processing applications.

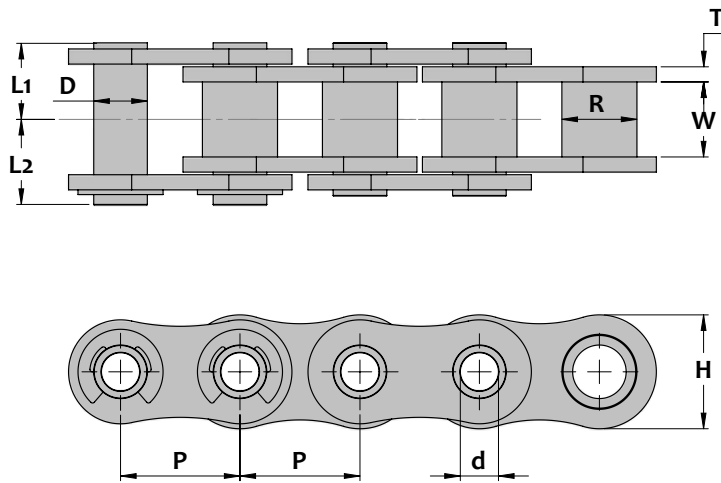

Chain Dimensions

MAXCO Chain Number	Units	Chain Pitch P	Bushing		Pin				Side Plate		Average Ultimate Strength Lbs Kg-f	Rated Working Load Lbs Kg-f	Average Chain Weight Lbs/ft Kg/m
			Dia. R	Inside Width W	Diameter		Length	Height H	Thick. T				
					D	d				L1			
40SSHP	inch	0.500	0.312	0.313	0.222	0.159	0.33	0.36	0.472	0.060	1,720	100	0.39
	mm	12.70	7.92	7.95	5.63	4.03	8.4	9.2	12.0	1.5	782	45	0.58
50SSHP	inch	0.625	0.400	0.375	0.279	0.202	0.40	0.44	0.591	0.080	2,650	155	0.67
	mm	15.875	10.16	9.53	7.09	5.13	10.1	11.2	15.0	2.0	1,205	70	0.97
60SSHP	inch	0.750	0.469	0.500	0.326	0.238	0.51	0.56	0.713	0.094	3,840	230	0.98
	mm	19.05	11.91	12.70	8.29	6.04	13.0	14.2	18.1	2.4	1,745	105	1.46
80SSHP	inch	1.000	0.625	0.625	0.446	0.318	0.64	0.71	0.949	0.126	6,970	400	1.66
	mm	25.4	15.88	15.88	11.34	8.08	16.2	18.1	24.1	3.2	3,170	182	2.47

ASME/ANSI Double Pitch Stainless Steel Hollow Pin Chain

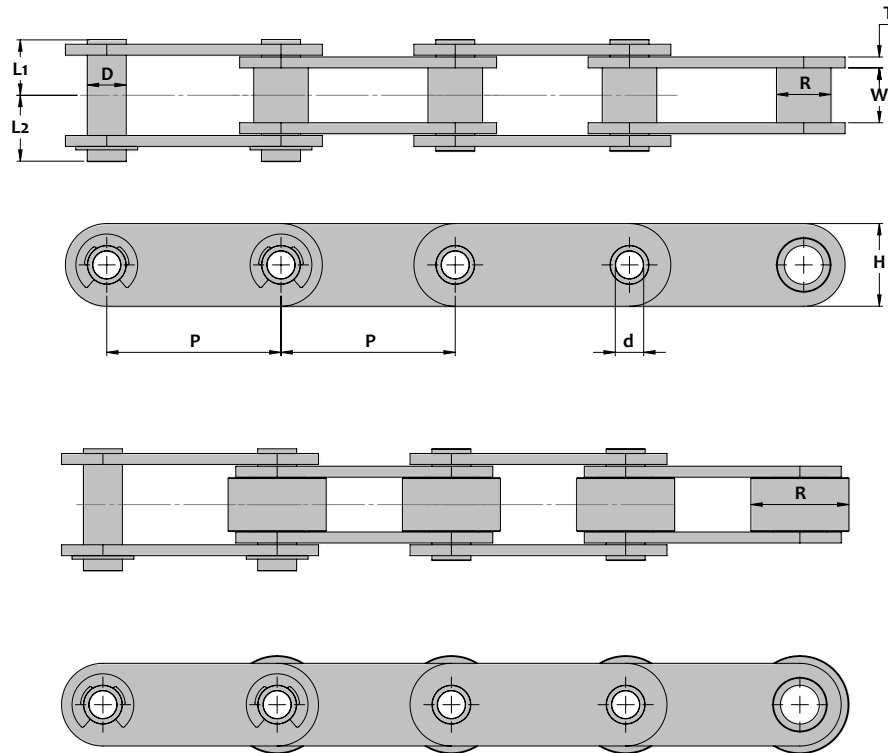

Chain Dimensions - Standard Roller

MAXCO Chain Number	Units	Chain Pitch P	Bushing/Roller		Pin				Side Plate		Average Ultimate Strength Lbs Kg-f	Rated Working Load Lbs Kg-f	Average Chain Weight Lbs/ft Kg/m
			Dia R	Inside Width W	Diameter		Length	Height H	Thick. T				
					D	d				L1			
C2040SSHP	inch	1.000	0.312	0.313	0.222	0.159	0.33	0.36	0.472	0.060	1,720	100	0.31
	mm	25.40	7.92	7.95	5.63	4.03	8.4	9.2	12.0	1.5	782	45	0.46
C2050SSHP	inch	1.250	0.400	0.375	0.279	0.202	0.40	0.44	0.591	0.080	2,650	155	0.51
	mm	31.75	10.16	9.53	7.09	5.13	10.1	11.2	15.0	2.0	1,205	70	0.76
C2060SSHP	inch	1.500	0.469	0.500	0.326	0.238	0.51	0.56	0.713	0.094	3,840	230	0.75
	mm	38.10	11.91	12.70	8.29	6.04	13.0	14.2	18.1	2.4	1,745	105	1.12
C2080SSHP	inch	2.000	0.625	0.625	0.446	0.318	0.64	0.71	0.949	0.126	6,970	400	1.33
	mm	50.80	15.88	15.88	11.34	8.08	16.2	18.1	24.1	3.2	3,170	182	1.98

Chain Dimensions - Large Roller

C2042SSHP	inch	1.000	0.625	0.313	0.222	0.159	0.33	0.36	0.472	0.060	1,720	100	0.54
	mm	25.40	15.88	7.95	5.63	4.03	8.4	9.2	12.0	1.5	782	45	0.81
C2052SSHP	inch	1.250	0.750	0.375	0.279	0.202	0.40	0.44	0.591	0.080	2,650	155	0.84
	mm	31.75	19.05	9.53	7.09	5.13	10.1	11.2	15.0	2.0	1,205	70	1.25
C2062SSHP	inch	1.500	0.875	0.500	0.326	0.238	0.51	0.56	0.713	0.094	3,840	230	1.20
	mm	38.10	22.23	12.70	8.29	6.04	13.0	14.2	18.1	2.4	1,745	105	1.79
C2082SSHP	inch	2.000	1.125	0.625	0.446	0.318	0.64	0.71	0.949	0.126	6,970	400	2.13
	mm	50.80	28.58	15.88	11.34	8.08	16.2	18.1	24.1	3.2	3,170	182	3.17

ASME/ANSI Standard Self-Lube Hollow Pin Chain

ASME/ANSI Hollow Pin chains are made from AISI Type 304 stainless steel for excellent corrosion and temperature resistance. These chains are often found in many food processing applications.

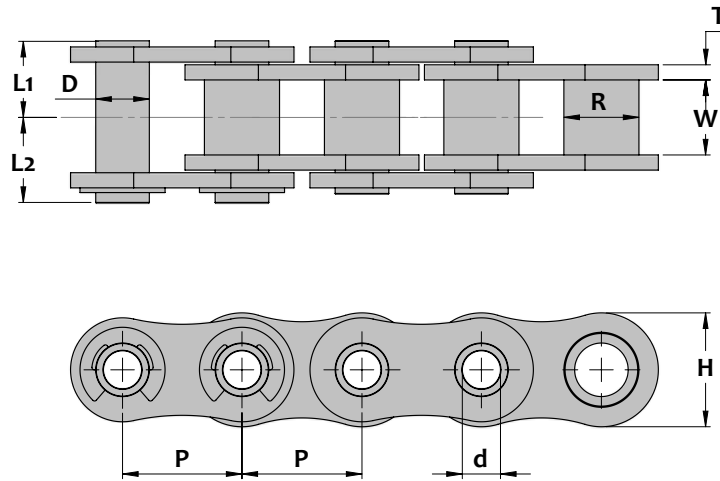

Chain Dimensions

MAXCO Chain Number	Units	Chain Pitch P	Bushing		Pin				Side Plate		Average Ultimate Strength Lbs Kg-f	Rated Working Load Lbs Kg-f	Average Chain Weight Lbs/ft Kg/m
			Dia.	Inside Width	Diameter		Length		Height	Thick.			
			R	W	D	d	L1	L2	H	T			
40SLHP	inch	0.500	0.312	0.313	0.222	0.159	0.33	0.36	0.472	0.060	2,860	400	0.39
	mm	12.70	7.92	7.95	5.63	4.03	8.4	9.2	12.0	1.5	1,300	182	0.58
50SLHP	inch	0.625	0.400	0.375	0.279	0.202	0.40	0.44	0.591	0.080	4,410	705	0.67
	mm	15.875	10.16	9.53	7.09	5.13	10.1	11.2	15.0	2.0	2,005	320	0.97
60SLHP	inch	0.750	0.469	0.500	0.326	0.238	0.51	0.56	0.713	0.094	6,390	950	0.98
	mm	19.05	11.91	12.70	8.29	6.04	13.0	14.2	18.1	2.4	2,905	432	1.46
80SLHP	inch	1.000	0.625	0.625	0.446	0.318	0.64	0.71	0.949	0.126	11,470	1,720	1.66
	mm	25.4	15.88	15.88	11.34	8.08	16.2	18.1	24.1	3.2	5,215	782	2.47

ASME/ANSI Double Pitch Self-Lube Hollow Pin Chain

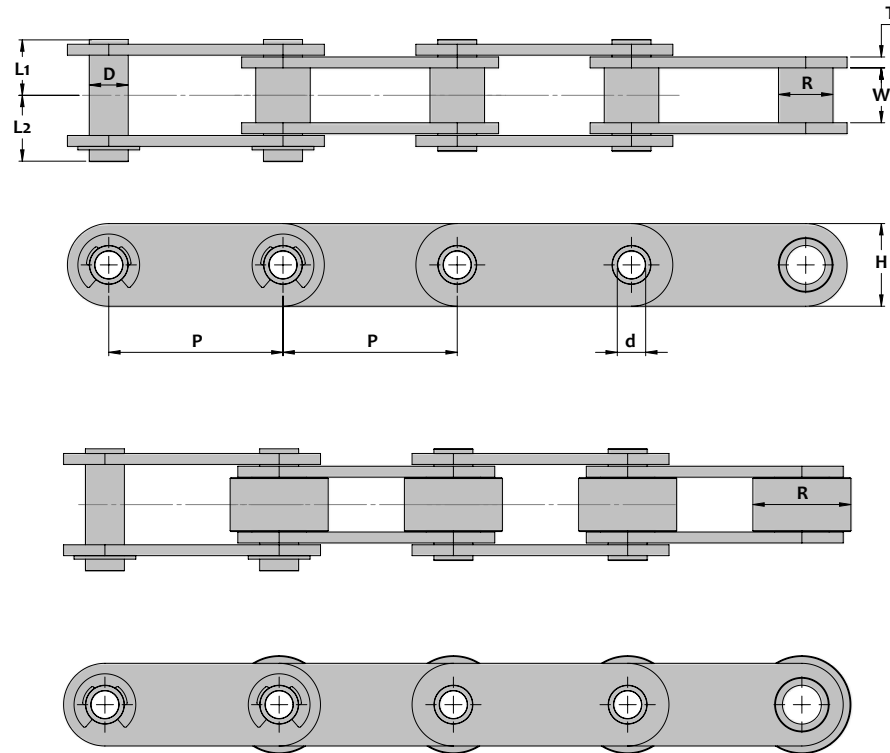

Chain Dimensions - Standard Roller

MAXCO Chain Number	Units	Chain Pitch P	Bushing/Roller		Pin				Side Plate		Average Ultimate Strength Lbs Kg-f	Rated Working Load Lbs Kg-f	Average Chain Weight Lbs/ft Kg/m
			Dia	Inside Width	Diameter		Length		Height	Thick.			
			R	W	D	d	L1	L2	H	T			
C2040SLHP	inch	1.000	0.312	0.313	0.222	0.159	0.33	0.36	0.472	0.060	2,860	400	0.31
	mm	25.40	7.92	7.95	5.63	4.03	8.4	9.2	12.0	1.5	1,300	182	0.46
C2050SLHP	inch	1.250	0.400	0.375	0.279	0.202	0.40	0.44	0.591	0.080	4,410	705	0.51
	mm	31.75	10.16	9.53	7.09	5.13	10.1	11.2	15.0	2.0	2,005	320	0.76
C2060SLHP	inch	1.500	0.469	0.500	0.326	0.238	0.51	0.56	0.713	0.094	6,390	950	0.75
	mm	38.10	11.91	12.70	8.29	6.04	13.0	14.2	18.1	2.4	2,905	432	1.12
C2080SLHP	inch	2.000	0.625	0.625	0.446	0.318	0.64	0.71	0.949	0.126	11,470	1,720	1.33
	mm	50.80	15.88	15.88	11.34	8.08	16.2	18.1	24.1	3.2	5,215	782	1.98

Chain Dimensions - Large Roller

C2042SLHP	inch	1.000	0.625	0.313	0.222	0.159	0.33	0.36	0.472	0.060	2,860	400	0.54
	mm	25.40	15.88	7.95	5.63	4.03	8.4	9.2	12.0	1.5	1,300	182	0.81
C2052SLHP	inch	1.250	0.750	0.375	0.279	0.202	0.40	0.44	0.591	0.080	4,410	705	0.84
	mm	31.75	19.05	9.53	7.09	5.13	10.1	11.2	15.0	2.0	2,005	320	1.25
C2062SLHP	inch	1.500	0.875	0.500	0.326	0.238	0.51	0.56	0.713	0.094	6,390	950	1.20
	mm	38.10	22.23	12.70	8.29	6.04	13.0	14.2	18.1	2.4	2,905	432	1.79
C2082SLHP	inch	2.000	1.125	0.625	0.446	0.318	0.64	0.71	0.949	0.126	11,470	1,720	2.13
	mm	50.80	28.58	15.88	11.34	8.08	16.2	18.1	24.1	3.2	5,215	782	3.17

Leaf Chain - General Information and Selection

Leaf Chains are made for high load, slow speed tension linkage applications. Often they are specified for reciprocating motion lifting devices such as fork lifts or cranes. These chains are typically supplied to a specific length and are connected to a clevis block at each end. The clevis may accommodate male ends (inside or sometimes called “articulating” links) or female ends (outside or the links on the pin link) as required (see illustration below)

Leaf chains are available in three series; AL (light duty), BL (heavy duty), or LL (European standard). For new selections we recommend the BL series in preference to the AL series as the latter has been discontinued as a recognized ASME/ANSI standard series chain. BL series chains are produced in accordance with the ASME/ANSI B29.8 American Leaf Chain Standard. LL series chains are produced in accordance with the ISO 606 international leaf chain standard.

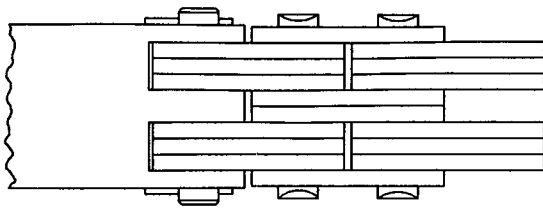

Female Clevis / Chain with Male Ends

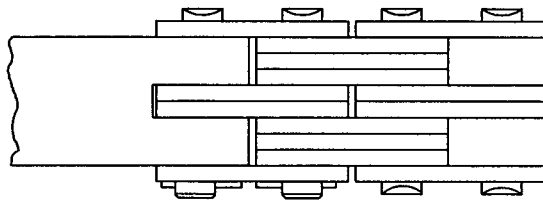

Male Clevis / Chain with Female Ends

A chain with an even number of pitches always has a one male and one female end. It is more common to have the chain possess an odd number of pitches in which case the both ends will be either male (most common) or female (less common). When ordering lengths with an odd number of pitches male ends are supplied unless otherwise noted. Clevis pins, usually with cotters at each end, are used to connect male chain ends to female clevis blocks. Chains with female ends are often (but not always) connected to the clevis block with a cottered type connecting link. The connecting link is the female end component in this case.

Leaf Chain Selection

Use the following formula to verify the selection of leaf chain:

$$\text{Minimum Ultimate Strength} > T \times DF \times SF$$

- T: Calculated Maximum Chain Tension
- DF: Duty Factor
- SF: Service Factor

Please see Chain Dimensions tables for the Minimum Ultimate Strength ratings of each chain size. The tables below provide information regarding the duty and service factors. Note that the maximum allowable chain speed for leaf chains is 100ft per minute.



Impact Loading	Service Factor (SF)
Smooth Operation	1.0
Moderate Impact	1.3
Severe Impact	1.5

Leaf Chain Series	Maximum cycles per day	Duty Factor (DF)
AL	10	9
	100	12
BL or LL	1,000	9

ASME/ANSI AL Series Leaf Chain

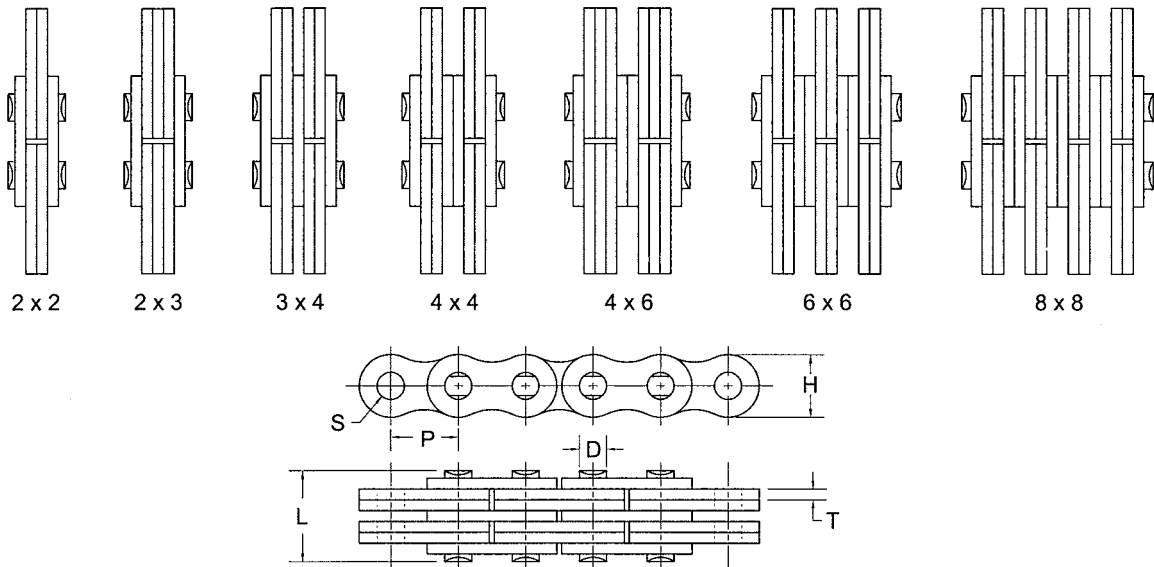

Chain Dimensions

MAXCO Chain Number	Units	Lacing	Chain Pitch P	Pin		Side Plate		Hole Dia. S	Minimum Ultimate Strength Lbs Kg-f	Average Ultimate Strength Lbs Kg-f	Average Chain Weight Lbs/ft Kg/m
				Dia D	Length L1	Height H	Thick. T				
AL422	inch	2 x 2	0.500	0.156	0.33	0.406	0.060	0.1586	3,700	4,180	0.24
	mm										
AL444	inch	4 x 4			0.57				7,500	8,385	0.47
	mm										
AL466	inch	6 x 6			0.83				11,300	12,570	0.70
	mm										
AL522	inch	2 x 2	0.625	0.200	0.41	0.500	0.080	0.2028	6,200	6,835	0.39
	mm										
AL544	inch	4 x 4			0.75				12,300	13,670	0.78
	mm										
AL566	inch	6 x 6			1.09				18,500	21,150	1.16
	mm										
AL622	inch	2 x 2	0.750	0.234	0.49	0.598	0.094	0.2378	8,700	9,690	0.54
	mm										
AL644	inch	4 x 4			0.87				17,400	19,400	1.13
	mm										
AL666	inch	6 x 6			1.28				26,000	29,000	1.65
	mm										
AL822	inch	2 x 2	1.000	0.312	0.65	0.795	0.125	0.3150	14,500	16,320	1.42
	mm										
AL844	inch	4 x 4			1.16				29,100	32,600	1.42
	mm										
AL866	inch	6 x 6			1.69				43,600	49,000	2.88
	mm										

ASME/ANSI AL Series Leaf Chain

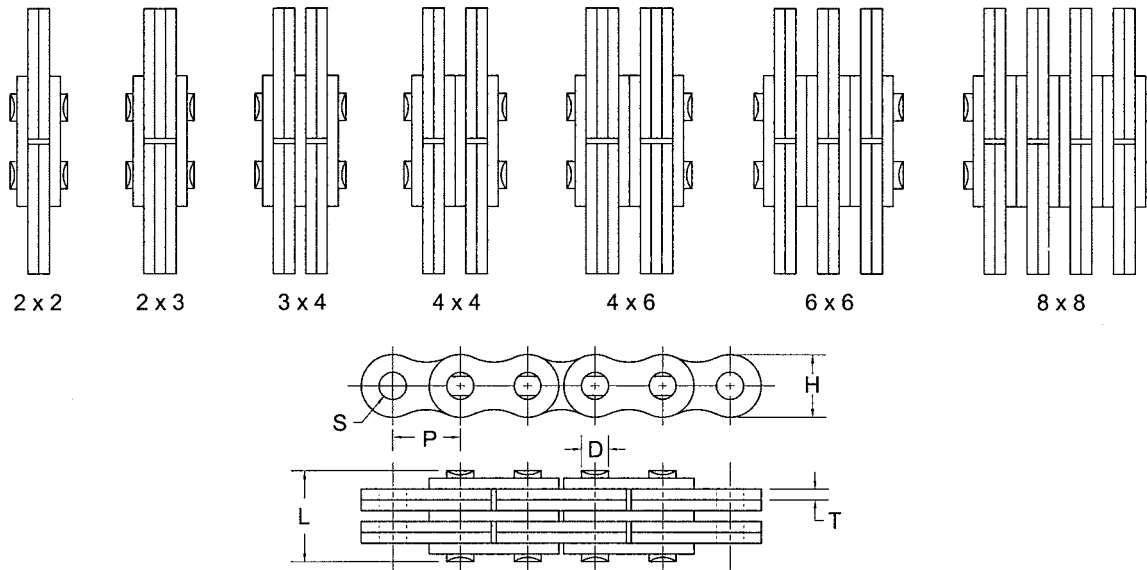

Chain Dimensions

MAXCO Chain Number	Units	Lacing	Chain Pitch P	Pin		Side Plate		Hole Dia. S	Minimum Ultimate Strength Lbs Kg-f	Average Ultimate Strength Lbs Kg-f	Average Chain Weight Lbs/ft Kg/m
				Dia D	Length L1	Height H	Thick. T				
AL1022	inch	2 x 2	1.250	0.375	0.77	0.965	0.157	0.3775	22,000	24,280	1.65
	mm			9.53	19.6	4.0	9.59	10,000	11,035	2.46	
AL1044	inch	4 x 4			1.43				44,100	48,560	3.23
	mm				36.2				20,045	22,075	4.81
AL1066	inch	6 x 6			2.11				66,100	72,840	4.85
	mm				53.5				30,045	33,110	7.24
AL1222	inch	2 x 2	1.500	0.437	0.94	1.150	0.188	0.4417	30,900	34,170	2.25
	mm			11.10	24.0	29.2	4.8	11.22	14,045	15,530	3.35
AL1244	inch	4 x 4			1.72				61,700	68,340	4.41
	mm				43.7				28,045	31,065	6.58
AL1266	inch	6 x 6			2.50				92,600	102,510	6.58
	mm				63.4				42,090	46,595	9.82
AL1422	inch	2 x 2	1.750	0.500	1.09	1.346	0.220	0.5047	41,900	46,090	3.35
	mm			12.70	27.8	34.2	5.6	12.82	19,045	20,950	4.99
AL1444	inch	4 x 4			2.02				83,800	92,170	6.41
	mm				51.2				38,090	41,895	9.56
AL1466	inch	6 x 6			2.90				125,700	138,250	9.48
	mm				73.6				57,135	62,840	14.13
AL1622	inch	2 x 2	2.000	0.562	1.25	1.587	0.250	0.5697	54,000	60,470	4.26
	mm			14.28	31.8	40.3	6.4	14.47	24,545	27,485	6.35
AL1644	inch	4 x 4			2.30				108,000	121,170	8.46
	mm				58.4				49,090	55,075	12.62
AL1666	inch	6 x 6			3.34				162,000	181,870	12.65
	mm				84.8				73,635	82,670	18.87

ASME/ANSI BL Series Leaf Chain

Chain Dimensions

MAXCO Chain Number	Units	Lacing	Chain Pitch P	Pin		Side Plate		Hole Dia. S	Minimum Ultimate Strength Lbs Kg-f	Average Ultimate Strength Lbs Kg-f	Average Chain Weight Lbs/ft Kg/m
				Dia D	Length L1	Height H	Thick. T				
BL423	inch	2 x 3	0.500	0.200	0.49	0.461	0.080	0.2028	5,500	6,180	0.53
	mm		12.70	5.08	12.5	11.7	2.0	5.15	2,500	2,810	0.79
BL434	inch	3 x 4			0.66				8,400	9,150	0.72
	mm				16.8				3,820	4,160	1.07
BL444	inch	4 x 4			0.75				11,000	12,230	0.82
	mm				19.0				5,000	5,560	1.22
BL446	inch	4 x 6			0.91				11,000	12,230	1.06
	mm				23.0				5,000	5,560	1.58
BL466	inch	6 x 6			1.08				16,500	18,550	1.27
	mm				27.5				7,500	8,430	1.89
BL523	inch	2 x 3	0.625	0.234	0.59	0.575	0.094	0.2378	8,800	9,600	0.80
	mm		15.875	5.95	15.0	14.6	2.4	6.04	4,000	4,365	1.19
BL534	inch	3 x 4			0.79				13,200	14,390	1.08
	mm				20.0				6,000	6,540	1.61
BL544	inch	4 x 4			0.87				17,600	19,180	1.21
	mm				22.2				8,000	8,720	1.80
BL546	inch	4 x 6			1.09				17,600	19,180	1.52
	mm				27.6				8,000	8,720	2.26
BL566	inch	6 x 6			1.28				25,800	28,550	1.78
	mm				32.4				11,725	12,975	2.65
BL623	inch	2 x 3	0.750	0.312	0.77	0.689	0.125	0.3150	14,300	15,870	1.27
	mm		19.05	7.93	19.5	17.5	3.2	8.00	6,500	7,215	1.89
BL634	inch	3 x 4			1.03				21,500	23,830	1.80
	mm				26.2				9,775	10,830	2.68
BL644	inch	4 x 4			1.15				28,700	31,700	2.04
	mm				29.2				13,045	14,410	3.04
BL646	inch	4 x 6			1.44				28,700	31,700	2.78
	mm				36.5				13,045	14,410	4.15
BL666	inch	6 x 6			1.69				42,800	47,660	3.07
	mm				43.0				19,455	21,665	4.58
BL823	inch	2 x 3	1.000	0.375	0.94	0.949	0.157	0.3776	23,200	25,630	2.13
	mm		25.40	9.53	23.8	24.1	4.0	9.59	10,545	11,650	3.17
BL834	inch	3 x 4			1.28				34,800	38,670	2.93
	mm				32.5				15,820	17,575	4.37
BL844	inch	4 x 4			1.43				46,000	51,260	3.32
	mm				36.2				21,045	23,300	4.95
BL846	inch	4 x 6			1.77				46,000	51,260	4.18
	mm				45.0				21,045	23,300	6.23
BL866	inch	6 x 6			2.11				69,000	76,890	4.99
	mm				53.5				31,365	34,950	7.44

ASME/ANSI BL Series Leaf Chain

Chain Dimensions

MAXCO Chain Number	Units	Lacing	Chain Pitch P	Pin		Side Plate		Hole Dia. S	Minimum Ultimate Strength Lbs Kg-f	Average Ultimate Strength Lbs Kg-f	Average Chain Weight Lbs/ft Kg/m
				Dia D	Length L1	Height H	Thick. T				
BL1023	inch	2 x 3	1.250	0.437	1.13	1.154	0.188	0.4409	31,700	35,300	3.11
	mm		31.75	11.10	28.6	29.3	4.8	11.20	14,410	16,045	4.64
BL1034	inch	3 x 4			1.52				49,600	55,080	4.36
	mm				38.7				22545	25,035	6.50
BL1044	inch	4 x 4			1.72				63,500	70,590	4.97
	mm				43.7				28,865	32,085	7.41
BL1046	inch	4 x 6			2.10				63,500	70,590	6.18
	mm				53.4				28,865	32,085	9.21
BL1066	inch	6 x 6			2.50				95,200	105,890	7.42
	mm				63.4				43,275	48,130	11.07
BL1223	inch	2 x 3	1.500	0.500	1.35	1.382	0.220	0.5047	41,900	46,540	4.33
	mm		38.10	12.70	34.2	35.1	5.6	12.82	16,045	21,155	6.46
BL1234	inch	3 x 4			1.79				67,200	74,640	6.07
	mm				45.5				25,035	33,925	9.05
BL1244	inch	4 x 4			2.02				83,800	93,070	6.89
	mm				51.2				38,090	42,305	10.27
BL1246	inch	4 x 6			2.46				83,800	93,070	7.95
	mm				62.6				38,090	42,305	11.86
BL1266	inch	6 x 6			2.90				125,400	139,610	9.66
	mm				73.6				57,000	63,460	14.40
BL1423	inch	2 x 3	1.750	0.562	1.53	1.610	0.250	0.5665	55,100	60,700	5.97
	mm		44.45	14.28	38.8	40.9	6.4	14.39	25,045	27,590	8.90
BL1434	inch	3 x 4			2.04				90,400	91,050	7.79
	mm				51.7				41,090	41,385	11.61
BL1444	inch	4 x 4			2.30				109,100	121,170	8.63
	mm				58.4				49,590	55,075	12.87
BL1446	inch	4 x 6			2.80				109,100	121,170	11.98
	mm				71.2				49,590	55,075	17.86
BL1466	inch	6 x 6			3.34				163,600	182,100	14.97
	mm				84.8				74,365	82,775	22.33
BL1623	inch	2 x 3	2.000	0.687	1.72	1.839	0.283	0.6937	79,400	88,130	8.10
	mm		50.80	17.45	43.7	46.7	7.2	17.62	36,090	40,060	12.08
BL1634	inch	3 x 4			2.32				124,600	138,930	11.30
	mm				58.9				56,635	63,150	16.85
BL1644	inch	4 x 4			2.59				158,700	176,480	12.64
	mm				65.9				72,135	80,220	18.85
BL1646	inch	4 x 6			2.59				158,700	176,480	16.05
	mm				65.9				72,135	80,220	23.94
BL1666	inch	6 x 6			3.16				238,100	264,380	19.14
	mm				80.2				108,225	120,175	28.54

ISO LL Series Leaf Chain

Chain Dimensions

MAXCO Chain Number	Units	Lacing	Chain Pitch P	Pin		Side Plate		Hole Dia. S	Minimum Ultimate Strength Lbs Kg-f	Average Chain Weight Lbs/ft Kg/m
				Dia D	Length L1	Height H	Thick. T			
LL0822	inch	2 x 2	0.500	0.175	0.30	0.429	0.050	0.1756	4,000	0.21
	mm		12.70	4.45	7.6	10.9	1.25	4.46	1.820	0.31
LL0844	inch	4 x 4			0.51				6,990	0.40
	mm				13.0				3.175	0.60
LL0866	inch	6 x 6			0.72				10,000	0.60
	mm				18.4				4.545	0.89
LL1022	inch	2 x 2	0.625	0.200	0.37	0.539	0.065	0.2004	4,990	0.32
	mm		15.875	5.08	9.3	13.7	1.65	5.09	2.270	0.48
LL1044	inch	4 x 4			0.63				10,000	0.63
	mm				16.1				4.545	0.94
LL1066	inch	6 x 6			0.90				15,000	0.94
	mm				22.9				6.820	1.40
LL1222	inch	2 x 2	0.750	0.225	0.42	0.634	0.071	0.2256	6,500	0.42
	mm		19.05	5.72	10.7	16.1	1.80	5.73	2.955	0.63
LL1244	inch	4 x 4			0.73				12,990	0.82
	mm				18.5				5.905	1.22
LL1266	inch	6 x 6			1.04				19,490	1.22
	mm				26.3				8.860	1.82
LL1622	inch	2 x 2	1.000	0.326	1.97	0.827	0.125	0.3268	13,040	0.99
	mm		25.40	8.28	50.1	21.0	3.20	8.30	5.925	1.48
LL1644	inch	4 x 4			1.19				26,080	1.94
	mm				30.2				11.855	2.90
LL1666	inch	6 x 6			1.70				39,120	2.89
	mm				43.2				17.780	4.31
LL2022	inch	2 x 2	1.250	0.401	0.79	1.039	0.138	0.4020	21,360	1.46
	mm		31.75	10.19	20.1	26.4	3.50	10.21	9.710	2.17
LL2044	inch	4 x 4			1.38				42,710	2.84
	mm				35.1				19.415	4.24
LL2066	inch	6 x 6			1.97				64,070	4.22
	mm				50.1				29.125	6.30
LL2422	inch	2 x 2	1.500	0.576	1.12	1.315	0.193	0.5768	38,220	2.70
	mm		38.10	14.63	28.4	33.4	4.90	14.65	17,375	4.02
LL2444	inch	4 x 4			1.94				76,430	5.22
	mm				49.4				34,740	7.79
LL2466	inch	6 x 6			2.77				114,650	7.74
	mm				70.4				52,115	11.55
LL2822	inch	2 x 2	1.750	0.626	1.34	1.457	0.248	0.6268	44,960	3.63
	mm		44.45	15.90	34.0	37.0	6.30	15.92	20,435	5.42
LL2844	inch	4 x 4			2.36				89,920	7.08
	mm				60.0				40,875	10.56
LL2866	inch	6 x 6			3.39				134,890	10.53
	mm				86.0				61,315	15.71
LL3222	inch	2 x 2	2.000	0.701	1.38	1.661	0.248	0.7020	58,450	3.97
	mm		50.80	17.81	35.0	42.2	6.30	17.83	26,570	5.92
LL3244	inch	4 x 4			2.40				116,900	7.71
	mm				61.0				53,135	11.50
LL3266	inch	6 x 6			3.43				175,350	11.44
	mm				87.0				79,705	17.06

Attachment Roller Chain - Single Pitch Nomenclature

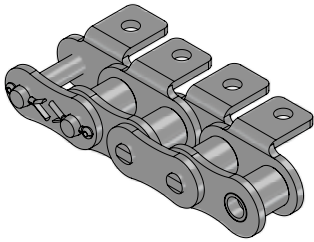

A-1
Bent Lug
One Side - One Hole

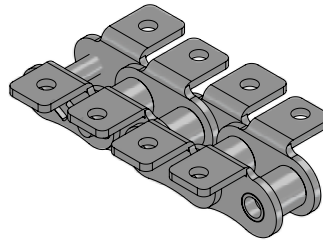

K-1
Bent Lug
Two Sides - One Hole

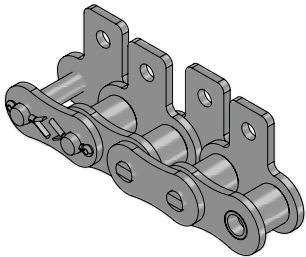

SA-1
Straight Lug
One Side - One Hole

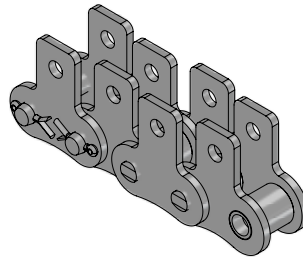

SK-1
Straight Lug
Two Sides - One Hole

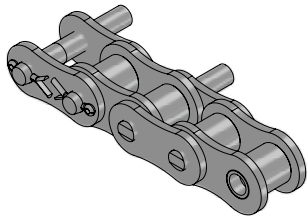

D-1
Extended Pin
One Pin Extended
per Pin Link

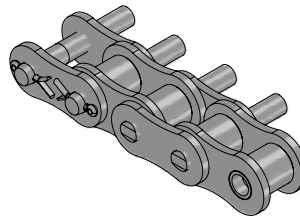

D-3
Extended Pin
Both Pins Extended
per Pin Link

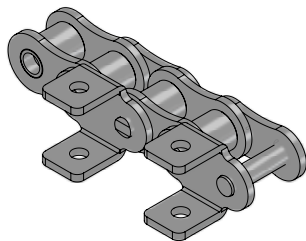

AA-1
Bent Double Lug
Up and Down
One Side - One Hole

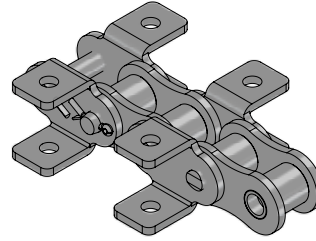

KK-1
Bent Double Lug
Up and Down
Two Sides - One Hole

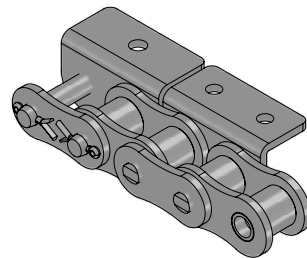

WA-1 or WA-2
Wide Contour
Bent Lug
One Side
One Hole (WA-1)
Two Holes (WA-2)

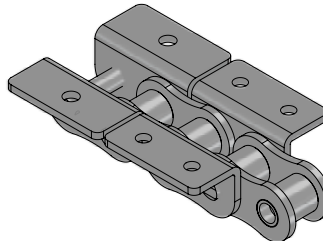

WK-1 or WK-2
Wide Contour
Bent Lug
Two Sides
One Hole (WK-1)
Two Holes (WK-2)

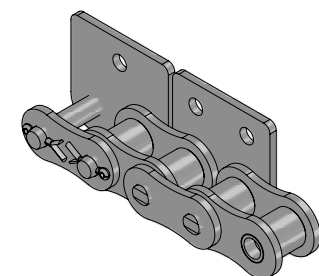

WSA-1 or WSA-2
Wide Contour
Straight Lug
One Side
One Hole (WSA-1)
Two Holes (WSA-2)

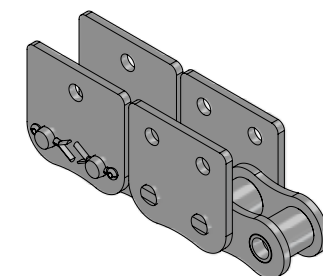

WSK-1 or WSK-2
Wide Contour
Straight Lug
Two Sides
One Hole (WSK-1)
Two Holes (WSK-2)

Attachment Roller Chain - Double Pitch Nomenclature

A-1/A-2

Bent Lug - One Side
One Hole (A-1) Two Holes (A-2)

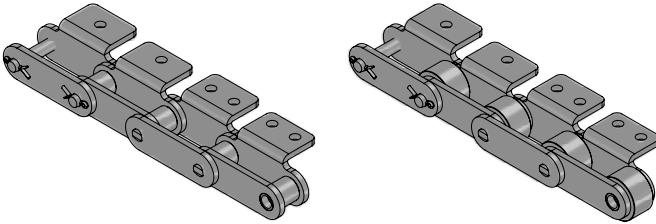

K-1/K-2

Bent Lug - Two Sides
One Hole (K-1) Two Holes (K-2)

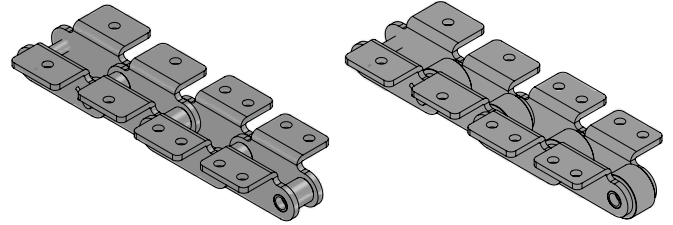

SA-1/SA-2

Straight Lug - One Side
One Hole (SA-1) Two Holes (SA-2)

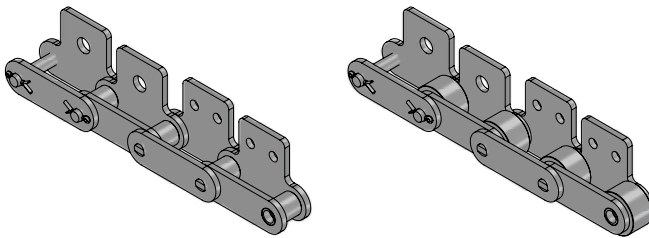

SK-1/SK-2

Straight Lug - Two Sides
One Hole (SK-1) Two Holes (SK-2)

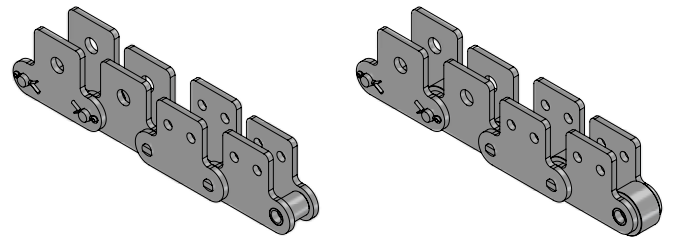

D-1

Extended Pin
One Pin Extended per Pin Link

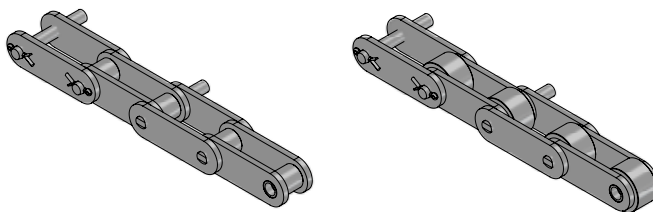

D-3

Extended Pin
Both Pins Extended per Pin Link

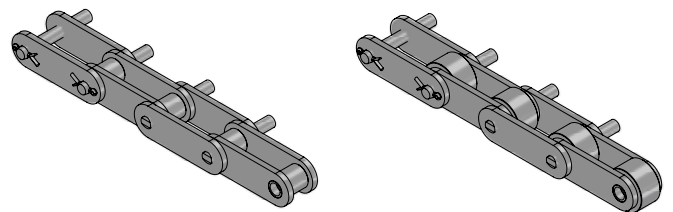

GK-1

Mid Pitch Hole
Both Sides

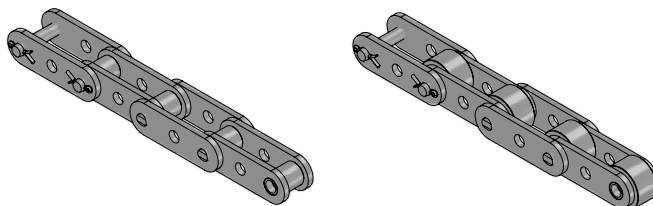

ASME/ANSI Standard Attachment Roller Chain

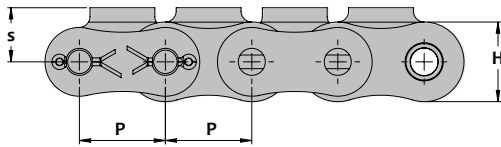
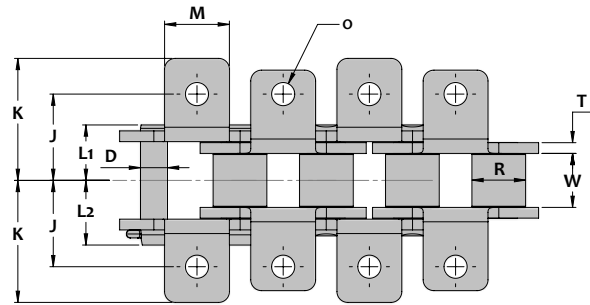
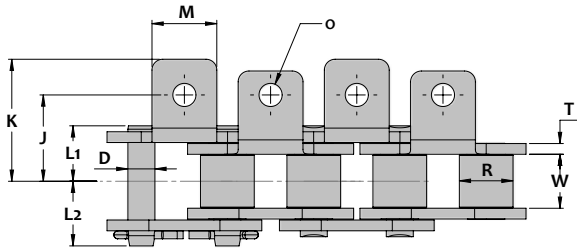

A-1 Attachment

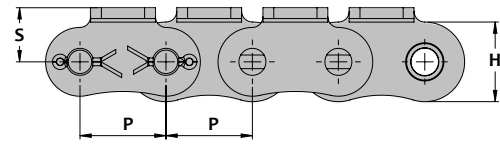

K-1 Attachment

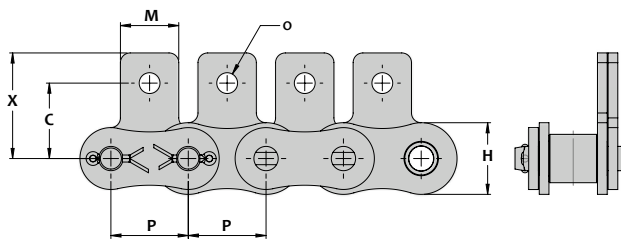
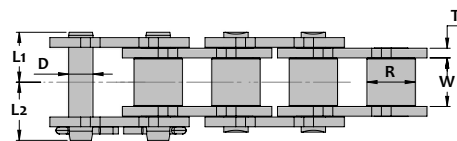
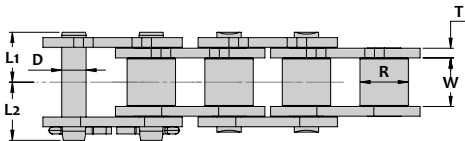

SA-1 Attachment

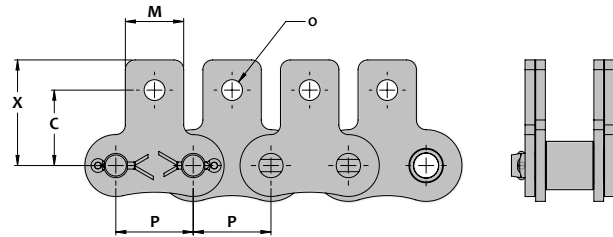

SK-1 Attachment

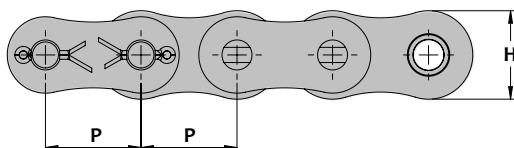
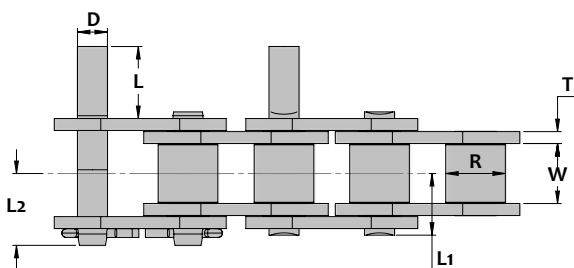

D-1 Attachment

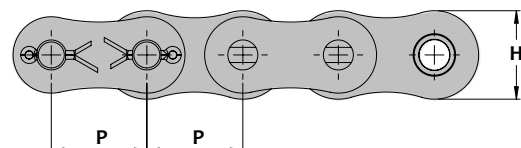
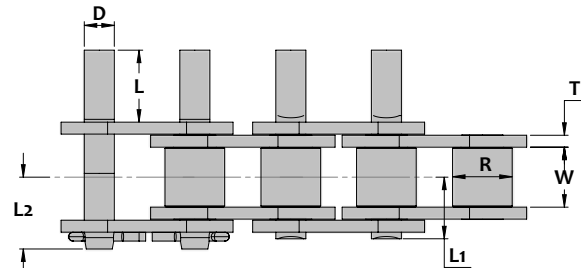

D-3 Attachment

ASME/ANSI Standard Attachment Roller Chain

Attachment Dimensions and Weights

MAXCO Chain Number	Units	Attachment Dimensions									Additional Weight/Attachment		
		All Attachments		Bent Lug			Straight Lug		Extended Pins		A, SA	K, SK	Ext. Pin
		M	O	S	J	K	C	X	D	L	Lbs/pc g/pc	Lbs/pc g/pc	Lbs/pc g/pc
35	inch	0.312	0.106	0.250	0.375	0.56	0.375	0.571	0.141	0.375	0.002	0.004	0.002
	mm	7.9	3.4	6.4	9.5	14.3	9.5	14.5	3.58	9.5	0.9	1.8	0.8
40	inch	0.375	0.142	0.312	0.500	0.68	0.500	0.728	0.156	0.375	0.003	0.005	0.002
	mm	9.5	3.6	7.9	12.7	17.3	12.7	18.5	3.96	9.5	1.2	2.4	1.0
50	inch	0.500	0.205	0.406	0.625	0.92	0.625	0.906	0.200	0.469	0.009	0.018	0.004
	mm	12.7	5.2	10.3	15.9	23.3	15.9	23.0	5.08	11.9	4.0	8.0	2.0
60	inch	0.625	0.205	0.469	0.750	1.11	0.720	1.051	0.234	0.563	0.014	0.029	0.007
	mm	15.9	5.2	11.9	19.1	28.1	18.3	26.7	5.95	14.3	6.5	13	3.0
80	inch	0.75	0.268	0.625	1.000	1.41	0.969	1.358	0.312	0.750	0.029	0.057	0.015
	mm	19.1	6.8	15.9	25.4	35.9	24.6	34.5	7.93	19.1	13	26	7.0
100	inch	1.000	0.346	0.780	1.250	1.74	1.250	1.693	0.375	0.937	0.060	0.12	0.026
	mm	25.4	8.8	19.8	31.8	44.3	31.8	43.0	9.53	23.8	27	54	12
120	inch	1.125	0.413	0.906	1.500	2.15	1.441	2.024	0.437	1.382	0.10	0.21	0.044
	mm	28.6	10.5	23.0	38.1	54.7	38.6	51.4	11.1	35.1	47	94	20
140	inch	1.366	0.472	1.125	1.750	2.49	1.748	2.484	0.500	1.610	0.14	0.29	0.066
	mm	34.7	12.0	28.6	44.5	63.2	44.4	63.1	12.7	40.9	65	130	30
160	inch	1.5	0.551	1.250	2.000	2.83	2.000	2.736	0.562	1.839	0.19	0.39	0.10
	mm	38.1	14.0	31.8	50.8	71.9	50.8	69.5	14.28	46.7	88	176	45

Base Chain Dimensions

MAXCO Chain Number	Units	Chain Pitch P	Roller		Pin		Side Plate		Rated Working Load				Ave Chain Weight Lbs/ft Kg/m	
			Roller Dia. R	Inside Width W	Pin Dia. D	Pin Length L1 L2	Height H	Thick. T	Carbon Steel Lbs Kg-f	304SS Lbs Kg-f	600SS Lbs Kg-f	Freedom Series C-Type Lbs Kg-f		
35	inch	0.375	0.200	0.188	0.141	0.24	0.27	0.354	0.050	365	60	90	-	0.23
	mm	9.525	5.08	4.78	3.58	6.0	6.9	9.0	1.25	166	27	41	-	0.34
40	inch	0.500	0.312	0.313	0.156	0.33	0.38	0.461	0.060	640	100	150	545	0.40
	mm	12.70	7.92	7.95	3.96	8.3	9.6	11.7	1.5	291	45	68	248	0.60
50	inch	0.625	0.400	0.375	0.200	0.40	0.46	0.575	0.080	1,000	150	225	850	0.66
	mm	15.875	10.16	9.53	5.08	10.2	11.8	14.6	2.0	455	68	102	386	0.98
60	inch	0.750	0.469	0.500	0.234	0.50	0.56	0.689	0.094	1,500	230	345	1,275	0.98
	mm	19.05	11.91	12.70	5.95	12.8	14.1	17.5	2.4	682	105	157	580	1.46
80	inch	1.000	0.625	0.625	0.312	0.65	0.75	0.921	0.126	2,570	400	600	2,185	1.69
	mm	25.4	15.88	15.88	7.93	16.4	19.1	23.4	3.2	1,170	182	273	993	2.52
100	inch	1.250	0.75	0.750	0.375	0.78	0.92	1.154	0.157	3,740	570	-	3,180	2.62
	mm	31.75	19.05	19.05	9.53	19.7	23.3	29.3	4.0	1,700	259	-	1,445	3.91
120	inch	1.500	0.875	1.000	0.437	0.98	1.13	1.382	0.188	5,640	-	-	4,795	3.86
	mm	38.10	22.23	25.40	11.10	24.8	28.6	35.1	4.8	2,565	-	-	2,180	5.76
140	inch	1.750	1.000	1.000	0.500	1.06	1.23	1.610	0.220	6,710	-	-	-	4.97
	mm	44.45	25.40	25.40	12.70	27.0	31.3	40.9	5.6	3,050	-	-	-	7.41
160	inch	2.000	1.125	1.250	0.562	1.27	1.44	1.839	0.250	9,270	-	-	-	6.56
	mm	50.80	28.58	31.75	14.27	32.2	36.5	46.7	6.4	4,215	-	-	-	9.79

ASME/ANSI Specialty Attachment Roller Chain

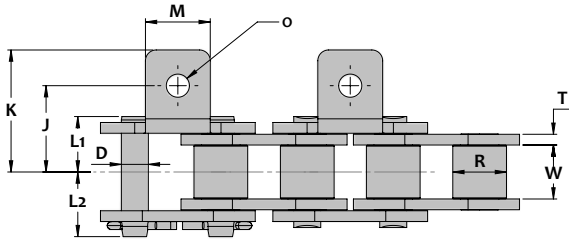

AA-1 Attachment

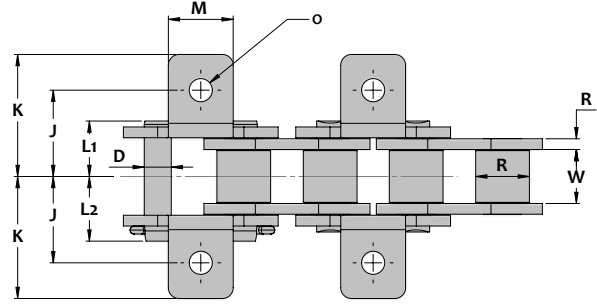

KK-1 Attachment

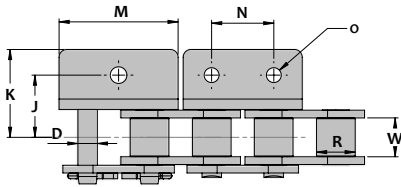
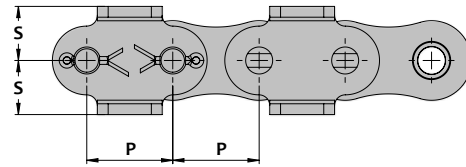
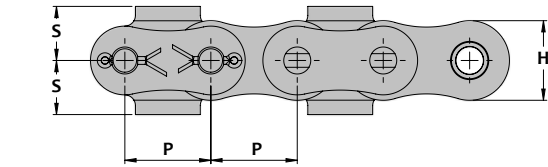

WA-1/WA-2 Attachment

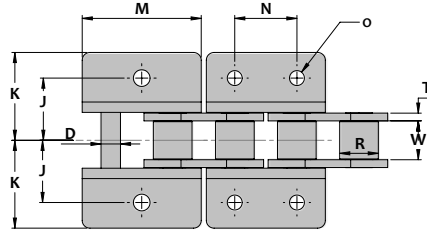

WK-1/WK-2 Attachment

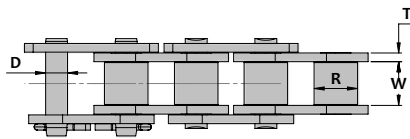
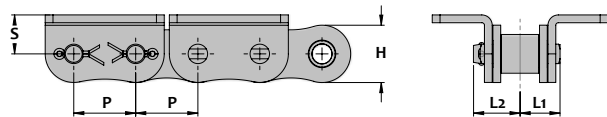
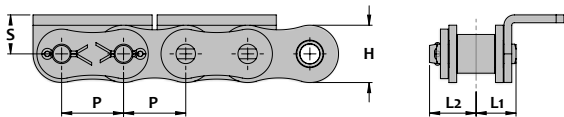

WSA-1/WSA-2 Attachment

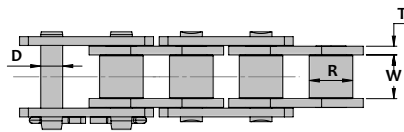

WSK-1/WSK-2 Attachment

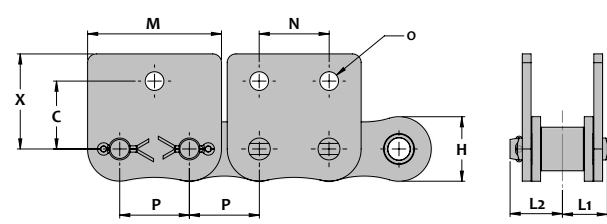
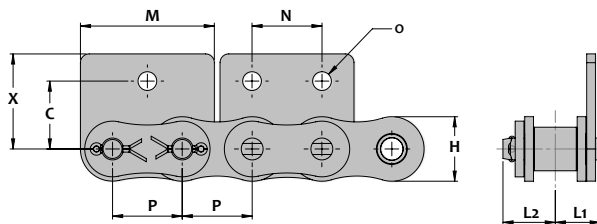

ASME/ANSI Specialty Attachment Roller Chain

Attachment Dimensions and Weights

MAXCO Chain Number	Units	Attachment Dimensions									Additional Weight/Attachment			
		All Attachments			Bent Lug			Straight Lug		AA, KK	WA, WSA	WK, WSK	AA	KK
		M	O	N	S	J	K	C	X	M	Lbs/pc g/pc	Lbs/pc g/pc	Lbs/pc g/pc	Lbs/pc g/pc
40	inch	0.957	0.142	0.500	0.312	0.500	0.68	0.500	0.681	0.375	0.007	0.014	0.007	0.014
	mm	24.3	3.6	12.7	7.9	12.7	17.3	12.7	17.3	9.5	3.2	6.4	3.2	6.4
50	inch	1.197	0.205	0.625	0.406	0.625	0.92	0.625	0.909	0.500	0.015	0.031	0.013	0.026
	mm	30.4	5.2	15.9	10.3	15.9	23.3	15.9	23.1	12.7	6.8	14	5.9	12
60	inch	1.457	0.205	0.750	0.469	0.750	1.11	0.720	1.067	0.625	0.026	0.053	0.024	0.049
	mm	37.0	5.2	19.1	11.9	19.1	28.1	18.3	27.1	15.9	12	24	11	22
80	inch	1.913	0.268	1.000	0.625	1.000	1.41	0.969	1.358	0.75	0.062	0.12	0.051	0.10
	mm	48.6	6.8	25.4	15.9	25.4	35.9	24.6	34.5	19.1	28	56	23	46
100	inch	2.402	0.346	1.250	0.780	1.250	1.74	1.250	1.693	1.000	0.12	0.24	0.11	0.21
	mm	61.0	8.8	31.8	19.8	31.8	44.3	31.8	43.0	25.4	55	110	48	96

Base Chain Dimensions

MAXCO Chain Number	Units	Chain Pitch P	Roller		Pin		Side Plate		Rated Working Load				Ave Chain Weight Lbs/ft Kg/m	
			Roller Dia. R	Inside Width W	Pin Dia. D	Pin Length		Height H	Thick. T	Carbon Steel	304SS	600SS		Freedom Series C-Type
						L1	L2			Lbs Kg-f	Lbs Kg-f	Lbs Kg-f		Lbs Kg-f
40	inch	0.500	0.312	0.313	0.156	0.33	0.38	0.461	0.060	640	100	150	545	0.40
	mm	12.70	7.92	7.95	3.96	8.3	9.6	11.7	1.5	291	45	68	248	0.60
50	inch	0.625	0.400	0.375	0.200	0.40	0.46	0.575	0.080	1,000	150	225	850	0.66
	mm	15.875	10.16	9.53	5.08	10.2	11.8	14.6	2.0	455	68	102	386	0.98
60	inch	0.750	0.469	0.500	0.234	0.50	0.56	0.689	0.094	1,500	230	345	1,275	0.98
	mm	19.05	11.91	12.70	5.95	12.8	14.1	17.5	2.4	682	105	157	580	1.46
80	inch	1.000	0.625	0.625	0.312	0.65	0.75	0.921	0.126	2,570	400	600	2,185	1.69
	mm	25.4	15.88	15.88	7.93	16.4	19.1	23.4	3.2	1,170	182	273	993	2.52
100	inch	1.250	0.75	0.750	0.375	0.78	0.92	1.154	0.157	3,740	570	-	3,180	2.62
	mm	31.75	19.05	19.05	9.53	19.7	23.3	29.3	4.0	1,700	259	-	1,445	3.91

ASME/ANSI Double Pitch Attachment Roller Chain

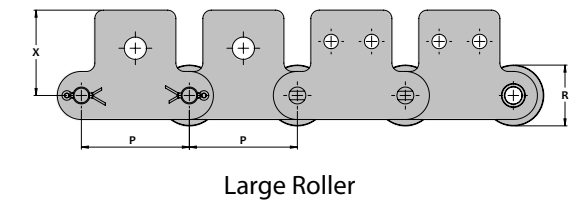
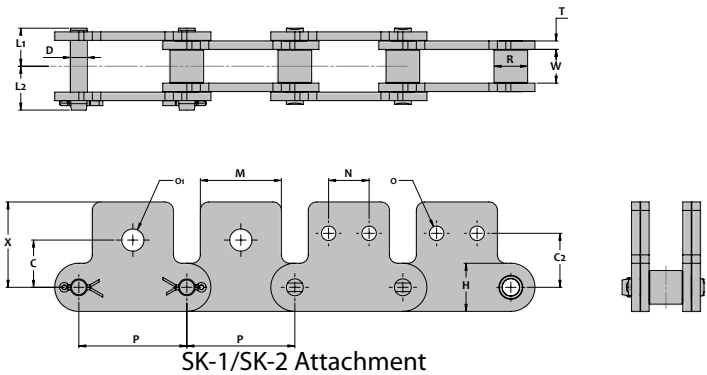
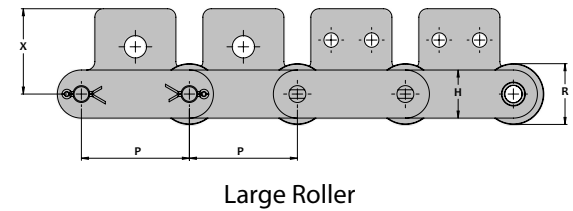
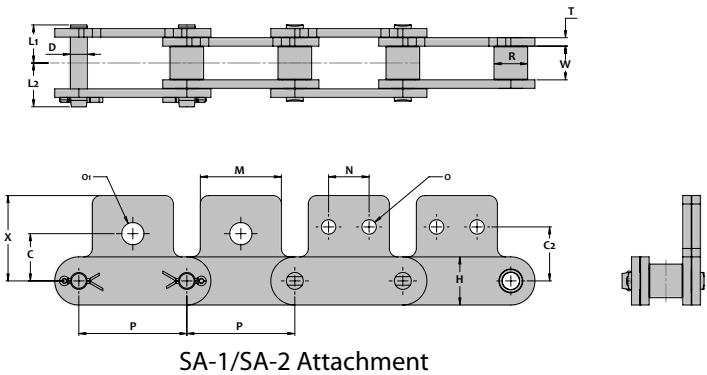
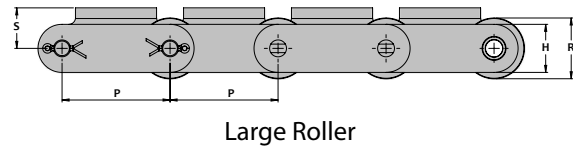
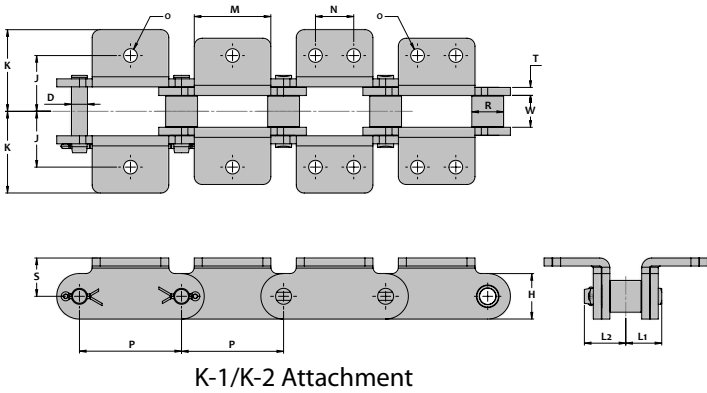
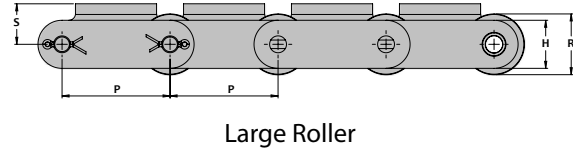
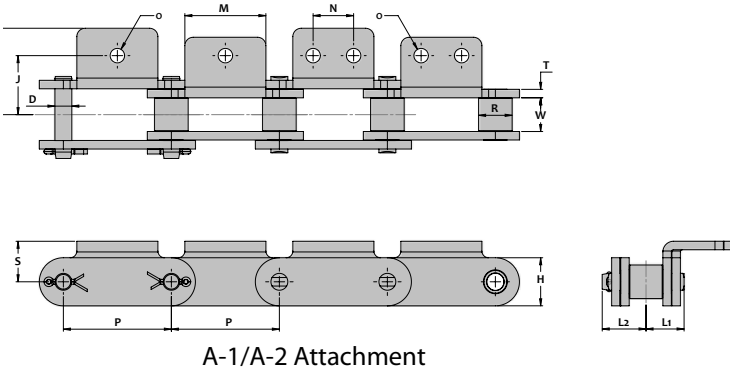

ASME/ANSI Double Pitch Attachment Roller Chain

Attachment Dimensions and Weights

MAXCO Chain Number	Units	Attachment Dimensions										Additional Weight/Attachment			
		All Attachments		Attachment Holes		Bent Lugs			Straight Lugs			A	K	SA	SK
		M	N	O	O1	S	J	K	C	C2	X	Lbs/pc g/pc	Lbs/pc g/pc	Lbs/pc g/pc	Lbs/pc g/pc
C2040 C2042	inch	0.750	0.375	0.142	0.205	0.358	0.500	0.75	0.437	0.531	0.78	0.007	0.014	0.006	0.012
	mm	19.1	9.5	3.6	5.2	9.1	12.7	19.1	11.1	13.5	19.8	3.2	6.3	2.7	5.4
C2050 C2052	inch	0.937	0.469	0.205	0.268	0.437	0.625	0.95	0.563	0.625	0.97	0.014	0.028	0.013	0.026
	mm	23.8	11.9	5.2	6.8	11.1	15.9	24.2	14.3	15.9	24.6	6.3	13	5.9	12
C2060H C2062H	inch	1.125	0.563	0.205	0.346	0.579	0.843	1.23	0.689	0.750	1.21	0.033	0.066	0.033	0.066
	mm	28.6	14.3	5.2	8.8	14.7	21.4	31.2	17.5	19.1	30.6	15	30	15	30
C2080H C2082H	inch	1.500	0.750	0.268	0.413	0.75	1.094	1.60	0.875	1.000	1.58	0.070	0.14	0.071	0.14
	mm	38.1	19.1	6.8	10.5	19.1	27.8	40.6	22.2	25.4	40.2	32	63	32	64
C2100H C2102H	inch	1.875	0.937	0.346	0.551	0.921	1.312	1.97	1.125	1.250	1.98	0.14	0.28	0.15	0.29
	mm	47.6	23.8	8.8	14.0	23.4	33.3	50.0	28.6	31.8	50.3	64	129	66	132
C2120H C2122H	inch	2.250	1.125	0.413	0.630	1.094	1.563	2.44	1.312	1.469	2.41	0.23	0.45	0.22	0.43
	mm	57.2	28.6	10.5	16.0	27.8	39.7	61.9	33.3	37.3	61.1	102	205	98	196

Base Chain Dimensions

MAXCO Chain Number	Units	Chain Pitch P	Roller		Pin		Side Plate		Rated Working Load				Ave Chain Weight Lbs/ft Kg/m	
			Roller Dia. R	Inside Width W	Pin Dia. D	Pin Length L1 L2		Height H	Thick. T	Carbon Steel Lbs Kg-f	304SS Lbs Kg-f	600SS Lbs Kg-f		Freedom Series C-Type Lbs Kg-f
C2040 C2042	inch	1.000	0.312 0.625	0.313	0.156	0.32	0.41	0.449	0.060	600	100	150	545	0.32 0.55
	mm	25.40	7.92 15.88	7.95	3.96	8.2	10.3	11.4	1.5	273	45	68	248	0.48 0.82
C2050 C2052	inch	1.250	0.400 0.750	0.375	0.200	0.40	0.46	0.591	0.080	990	150	225	850	0.55 0.84
	mm	31.75	10.16 19.05	9.53	5.08	10.2	11.8	15.0	2.0	450	68	102	386	0.82 1.26
C2060H C2062H	inch	1.500	0.469 0.875	0.500	0.234	0.57	0.65	0.669	0.126	1,440	250	375	1,275	0.93 1.39
	mm	38.10	11.91 22.23	12.70	5.95	14.4	16.6	17.0	3.2	655	114	170	993	1.38 2.08
C2080H C2082H	inch	2.000	0.625 1.125	0.625	0.312	0.70	0.83	0.890	0.157	2,460	420	630	2,185	1.56 2.25
	mm	50.80	15.88 28.58	15.88	7.93	17.8	21.0	22.6	4.0	1,120	191	286	993	2.32 3.36
C2100H C2102H	inch	2.500	0.750 1.562	0.750	0.375	0.83	0.97	1.126	0.189	3,760	600	-	-	2.32 3.78
	mm	63.50	19.05 39.67	19.05	9.53	21.1	24.6	28.6	4.8	1,710	273	-	-	3.46 5.64
C2120H C2122H	inch	3.000	0.875 1.750	1.000	0.437	1.04	1.21	1.374	0.220	5,430	900	-	-	3.30 5.28
	mm	76.20	22.23 44.45	25.40	11.10	26.3	30.7	34.9	5.6	2,470	409	-	-	4.92 7.87

ASME/ANSI Double Pitch Attachment Roller Chain

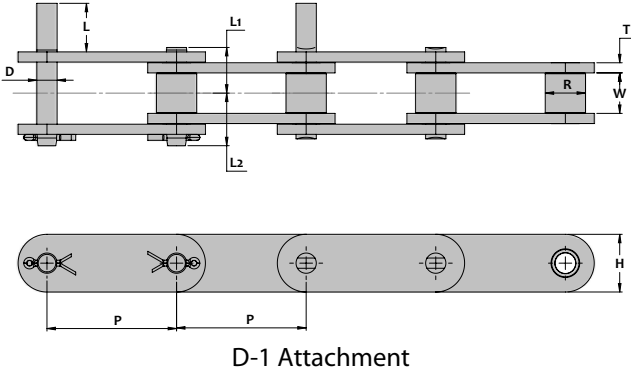

D-1 Attachment

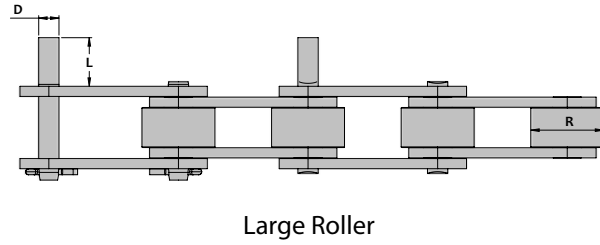

Large Roller

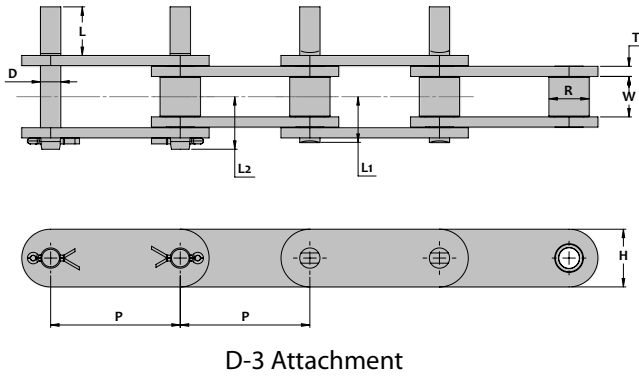

D-3 Attachment

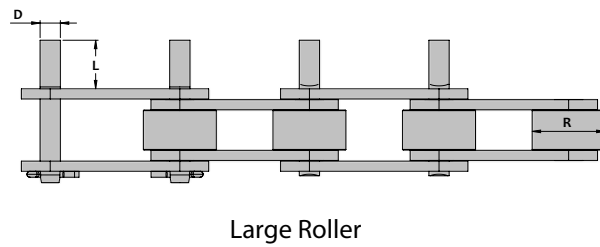

Large Roller

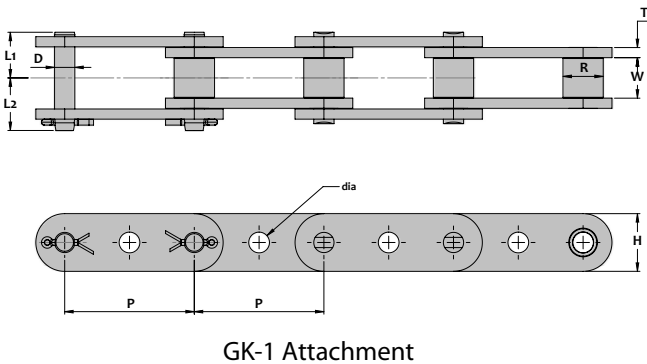

GK-1 Attachment

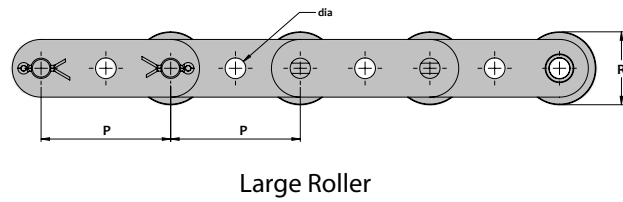

Large Roller

ASME/ANSI Double Pitch Attachment Roller Chain

Attachment Dimensions and Weights

MAXCO Chain Number	Units	Extended Pins			GK-1 Attachments					
		D	L	Additional Weight per extended pin Lb/pc g/pc	Attachment Hole Diameter dia					
C2040 C2042	inch	0.156	0.375	0.001	0.160					
	mm	3.96	9.5	0.5	4.06					
C2050 C2052	inch	0.200	0.469	0.002	0.200	0.205	0.240	0.250	0.315	0.325
	mm	5.08	11.9	1.0	5.08	5.21	6.10	6.35	8.00	8.26
C2060H C2062H	inch	0.234	0.563	0.004		0.240	0.250	0.280	0.320	
	mm	5.95	14.3	2.0		6.10	6.35	7.11	8.13	
C2080H C2082H	inch	0.312	0.750	0.007			0.315	0.320		
	mm	7.93	19.1	3.0			8.00	8.13		
C2100H C2102H	inch	0.375	0.937	0.015	0.400					
	mm	9.53	23.8	7.0	10.16					
C2120H C2122H	inch	0.437	1.125	0.026	0.475					
	mm	11.10	28.6	12.0	12.07					

Base Chain Specifications

MAXCO Chain Number	Units	Chain Pitch P	Roller		Pin		Side Plate		Rated Working Load				Ave Chain Weight Lbs/ft Kg/m	
			Roller Dia. R	Inside Width W	Pin Dia. D	Pin Length L1 L2	Height H	Thick. T	Carbon Steel Lbs Kg-f	304SS Lbs Kg-f	600SS Lbs Kg-f	Freedom Series C-Type Lbs Kg-f		
C2040 C2042	inch	1.000	0.312 0.625	0.313	0.156	0.32	0.41	0.449	0.060	600	100	150	545	0.32 0.55
	mm	25.40	7.92 15.88	7.95	3.96	8.2	10.3	11.4	1.5	273	45	68	248	0.48 0.82
C2050 C2052	inch	1.250	0.400 0.750	0.375	0.200	0.40	0.46	0.591	0.080	990	150	225	850	0.55 0.84
	mm	31.75	10.16 19.05	9.53	5.08	10.2	11.8	15.0	2.0	450	68	102	386	0.82 1.26
C2060H C2062H	inch	1.500	0.469 0.875	0.500	0.234	0.57	0.65	0.669	0.126	1,440	250	375	1,275	0.93 1.39
	mm	38.10	11.91 22.23	12.70	5.95	14.4	16.6	17.0	3.2	655	114	170	993	1.38 2.08
C2080H C2082H	inch	2.000	0.625 1.125	0.625	0.312	0.70	0.83	0.890	0.157	2,460	420	630	2,185	1.56 2.25
	mm	50.80	15.88 28.58	15.88	7.93	17.8	21.0	22.6	4.0	1,120	191	286	993	2.32 3.36
C2100H C2102H	inch	2.500	0.750 1.562	0.750	0.375	0.83	0.97	1.126	0.189	3,760	600	-	-	2.32 3.78
	mm	63.50	19.05 39.67	19.05	9.53	21.1	24.6	28.6	4.8	1,710	273	-	-	3.46 5.64
C2120H C2122H	inch	3.000	0.875 1.750	1.000	0.437	1.04	1.21	1.374	0.220	5,430	900	-	-	3.30 5.28
	mm	76.20	22.23 44.45	25.40	11.10	26.3	30.7	34.9	5.6	2,470	409	-	-	4.92 7.87

ISO 606B British Standard Attachment Roller Chain

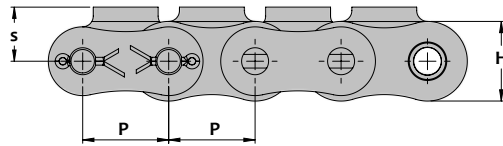
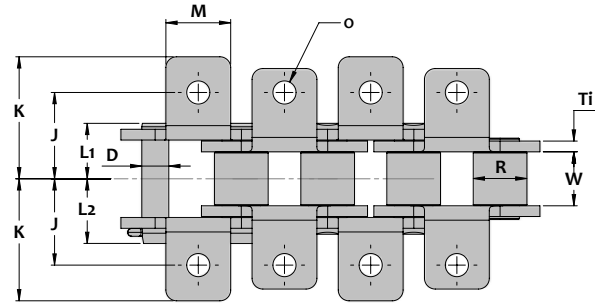
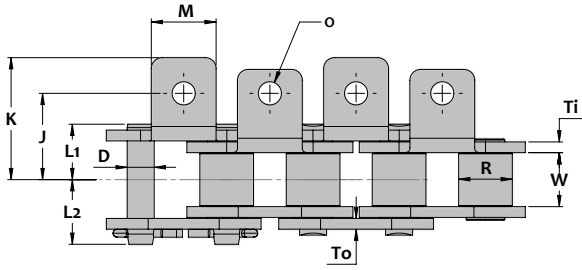

A-1 Attachment

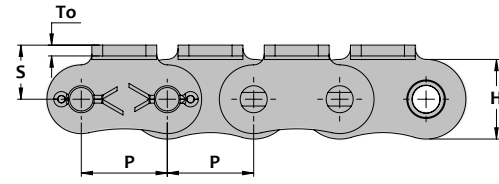

K-1 Attachment

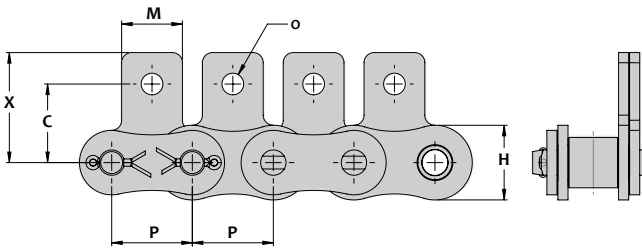
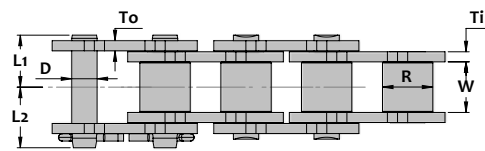
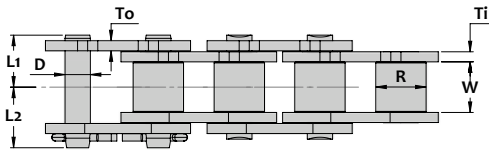

SA-1 Attachment

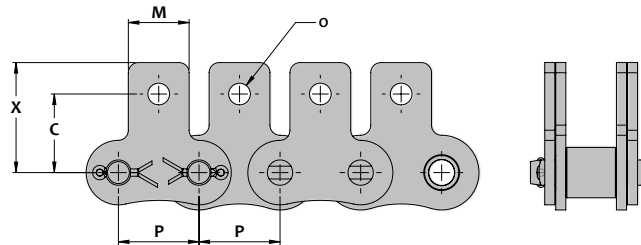

SK-1 Attachment

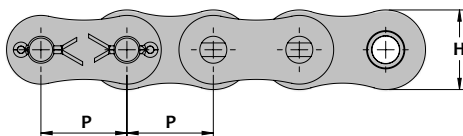
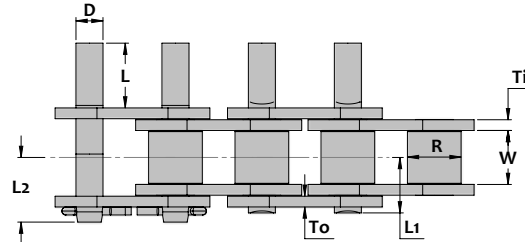
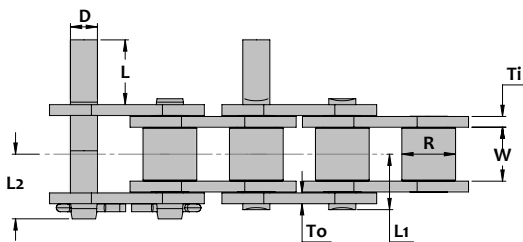

D-1 Attachment

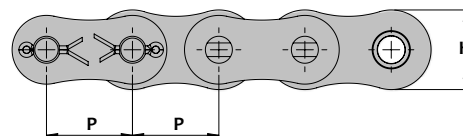

D-3 Attachment

ISO 606B British Standard Attachment Roller Chain

Attachment Dimensions and Weights

MAXCO Chain Number	Units	Attachment Dimensions									Additional Weight/Attachment		
		All Attachments		Bent Lug			Straight Lug		Extended Pin		A, SA	K, SK	Ext Pin
		M	O	S	J	K	C	X	D	L	Lbs/pc g/pc	Lbs/pc g/pc	Lbs/pc g/pc
08B	inch	0.433	0.169	0.335	0.543	0.82	0.539	0.819	0.175	0.583	0.004	0.009	0.004
	mm	11.0	4.3	8.5	13.8	20.9	13.7	20.8	4.45	14.8	2.0	4.0	1.8
10B	inch	0.551	0.209	0.413	0.622	0.95	0.650	0.980	0.200	0.693	0.007	0.014	0.006
	mm	14.0	5.3	10.5	15.8	24.2	16.5	24.9	5.06	17.6	3.2	6.4	2.8
12B	inch	0.709	0.252	0.480	0.693	1.07	0.728	1.106	0.225	0.815	0.010	0.020	0.009
	mm	18.0	6.4	12.2	17.6	27.3	18.5	28.1	5.72	20.7	4.5	9.0	4.1
16B	inch	0.945	0.331	0.669	1.142	1.65	1.079	1.575	0.326	1.311	0.44	0.088	0.031
	mm	24.0	8.4	17.0	29.0	41.9	27.4	40.0	8.28	33.3	20	40	14
20B	inch	1.181	0.413	0.827	1.358	1.94	1.299	1.870	0.400	1.508	0.055	0.110	0.054
	mm	30.0	10.5	21.0	34.5	49.3	33.0	47.5	10.16	38.3	25	50	24.3

Base Chain Dimensions

MAXCO Chain Number	Units	Chain Pitch P	Roller		Pin		Side Plate			Rated Working Load			Ave Chain Weight Lbs/ft Kg/m	
			Roller Dia. R	Inside Width W	Pin Dia. D	Pin Length L1 L2		Height H	Thickness Ti To		Carbon Steel	304SS		Freedom Series C-Type
												Lbs Kg-f		Lbs Kg-f
08B	inch	0.500	0.335	0.305	0.175	0.33	0.39	0.465	0.060		705	105	600	0.41
	mm	12.70	8.51	7.75	4.45	8.4	9.8	11.8	1.5		320	48	273	0.61
10B	inch	0.625	0.400	0.380	0.200	0.37	0.44	0.579	0.065		895	145	760	0.60
	mm	15.875	10.16	9.65	5.08	9.5	11.2	14.7	1.65		407	66	345	0.89
12B	inch	0.750	0.475	0.460	0.225	0.43	0.50	0.634	0.070		1,150	195	980	0.76
	mm	19.05	12.07	11.68	5.72	11.0	12.6	16.1	1.8		523	89	445	1.14
16B	inch	1.000	0.625	0.670	0.325	0.69	0.81	0.827	0.157	0.125	2,460	455	2,090	1.74
	mm	25.4	15.88	17.02	8.26	17.6	20.6	21.0	4.0	3.2	1,120	207	950	2.59
20B	inch	1.250	0.750	0.770	0.400	0.79	0.94	1.039	0.177	0.138	3,810	-	3,240	2.52
	mm	31.75	19.05	19.56	10.16	20.1	23.9	26.4	4.5	3.5	1,730	-	1,475	3.76

Conveyor Chain Selection

Introduction

A careful assessment of the conditions surrounding a conveyor is necessary for accurate conveyor chain selection. This section discusses the basic considerations required for successful conveyor chain selection. Roller Chains are often used for light to moderate duty material handling applications. Environmental conditions may require the use of special materials, platings coatings, lubricants or the ability to operate without additional external lubrication. Please contact MAXCO Chain, Ltd. engineering personnel for assistance with these special applications.

Basic Information Required For Chain Selection

- Type of chain conveyor (unit or bulk) including the method of conveyance (attachments, buckets, through rods etc).
- Conveyor layout including sprocket locations, inclines (if any) and the number of chain strands (**N**) to be used.
- Amount of material (**M** in lbs/ft or kN/m) and type of material to be conveyed.
- Estimated weight of conveyor components (**W** in lbs/ft or kN/m) including chain, slats or attachments (if any).
- Linear chain speed (**S** in ft/min or m/min).
- Environment in which the chain will operate including temperature, corrosion circumstance, lubrication condition etc.

Step 1: Estimate Chain Tension

Use the formula below to estimate the conveyor Pull (P_{est}) and then the chain tension (T_{est}).

$$P_{est} = (M + W) \times f \times SF$$

and

$$T_{est} = P_{est} / N$$

f = Coefficient of Friction (see Table 1 on Page 131).
 SF = Speed Factor (see Table 2 on Page 131).

Step 2: Make A Tentative Chain Selection

Using the T_{est} value, make a tentative selection by choosing a chain whose rated working load greater than the calculated T_{est} value. Rated working loads are found in the tables on pages 120 - 129. These values are appropriate for conveyor service and are different from those shown in tables at the front of the catalog which are related to slow speed drive chain usage.

In addition to sufficient load carrying capacity often these chains must be of a certain pitch to accommodate a desired attachment spacing. For example if slats are to be bolted to an attachment every 1.5 inches, the pitch of the chain selected must divide into 1.5". Thus one could use a 40 chain (1/2" pitch) with the attachments every 3rd, a 60 chain (3/4" pitch) with the attachments every 2nd, a 120 chain (1-1/2" pitch) with the attachments every pitch or a C2060H chain (1-1/2" pitch) with the attachments every pitch.

Step 3: Finalize Selection - Calculate Actual Conveyor Pull

After making a tentative selection we need to verify it by calculating the actual chain tension (T). To do this we must first calculate the actual conveyor pull (P). From the layouts shown on the right side of this page choose the appropriate formula and calculate the total conveyor pull. Note that some conveyors may be a combination of horizontal, inclined and vertical . . . in that case calculate the conveyor Pull at each section and add them together.

Horizontal Conveyor

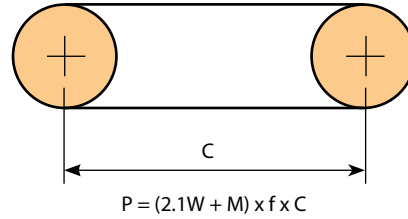

C = Center distance (ft or m)

Incline Conveyor

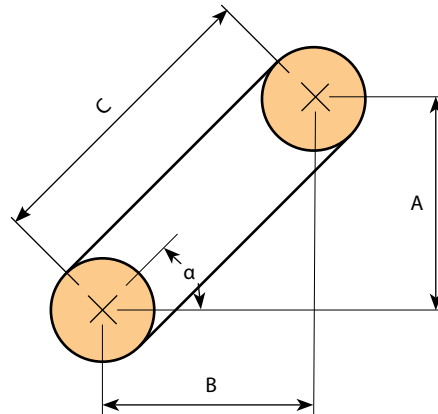

$$P = [(M + W) \times C \times (f \times \cos \alpha + \sin \alpha)] + [1.1W \times C \times (f \times \cos \alpha - \sin \alpha)]$$

C = Center distance (ft or m)

Vertical Conveyor

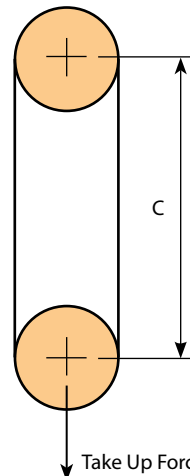

$$P = [(M + W) \times C] + 1/2 \text{ Take Up Force}$$

C = Center distance (ft or m)

Conveyor Chain Selection

Table 1: Coefficient of Friction (f)

Type of Carrier	Dry	Lubricated
Standard Roller	0.21	0.14
Large Roller	0.12	0.08
Top Roller	0.09	0.06
Chain Sliding on Steel	0.33	0.24

Table 2: Speed Factor (SF)

Chain Speed		Speed Factor
0 - 50 ft/min	0 - 15 m/min	1.0
50 - 100 ft/min	15 - 30 m/min	1.2
100 - 150 ft/min	30 - 45 m/min	1.4
150 - 230 ft/min	45 - 70 m/min	1.6
230 - 300 ft/min	70 - 90 m/min	2.2
300 - 350 ft/min	90 - 105 m/min	2.8
350 - 400 ft/min	105 - 120 m/min	3.2
> 400 ft/min	> 120 m/min	Consult MAXCO

Table 3: Multi-Strand Factor (MSF)

Number of Strands	MSF
1	1.0
2	1.2
3	1.3
4	1.4
More than 4	Consult MAXCO

Table 4: Temperature Factor (TF)

Number of Strands	TF
-20° to -4° F -30° to -20° C	4.0
-4° to 15° F -20° to -10° C	3.0
15° to 300° F -10° to 150° C	1.0
300° to 390° F 150° to 200° C	1.3
390° to 450° F 200° to 230° C	2.0
> 450° F > 230° C	Consult MAXCO

Step 4: Calculate Maximum Chain Tension

The Maximum Chain Tension (T) equals the Conveyor Pull (P) as calculated in Step 3 divided by the number of strands carrying the load (N), times the Speed Factor (SF) shown in Table 2, the Multi-Strand Factor (MSF) shown in Table 3 and the Temperature Factor (TF) shown in Table 4.

$$T = (P / N) \times MSF \times SF \times TF$$

Step 5: Check the "Rated Working Load" of the Selected Chain

The "Rated Working Load" of the selected chain should be greater than the Maximum Chain Tension (T) calculated in Step 4 above. Rated working loads are found in the tables on pages 120 - 129. These values are appropriate for conveyor service and are different from those shown in tables at the front of the catalog which are related to slow speed drive chain usage.

Step 6: Check the "Allowable Roller Load" of the Selected Chain

For chains that roll on the chain rollers or on top roller attachments it is necessary to check the Allowable Roller Load" shown in Table 5 below. Top rollers can be considered Large steel or plastic rollers in the table below.

Note: the Roller load is determined by:

$$\text{Roller Load} = W_r / N_r$$

W_r = The total weight carried by the rollers

N_r = The number of rollers supporting the weight.

Table 5 Allowable Roller Load

Chain Number	Steel Standard Roller Lbs / Kg-f	Steel Large Roller Lbs / Kg-f	Plastic Large Roller Lbs / Kg-f
40	33 / 15	-	-
50	44 / 20	-	-
60	66 / 30	-	-
80	120 / 55	-	-
100	180 / 82	-	-
120	260 / 118	-	-
140	300 / 136	-	-
160	430 / 195	-	-
C2040 C2042	33 / 15	143 / 65	44 / 20
C2050 C2052	44 / 20	220 / 100	66 / 30
C2060H C2062H	66 / 30	350 / 159	110 / 50
C2080H C2082H	120 / 55	590 / 268	200 / 91
C2100H C2102H	180 / 82	880 / 400	290 / 132
C2120H C2122H	260 / 118	1,320 / 600	-
C2160H C2162H	430 / 195	2,160 / 982	-

ASME/ANSI Standard Roller Chain

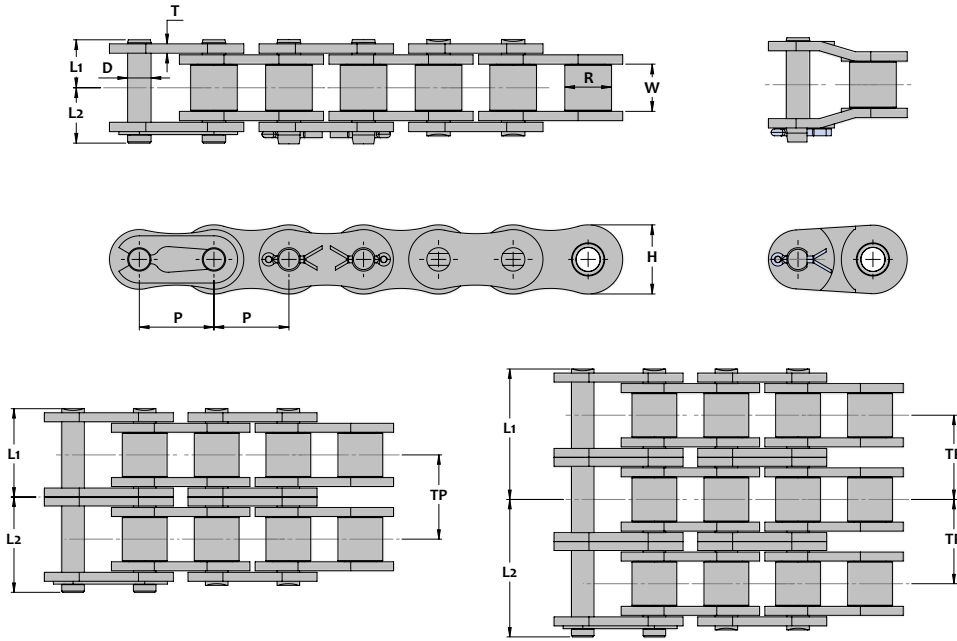

Chain Dimensions

MAXCO Chain Number	Units	Chain Pitch P	Roller		Pin		Side Plate		Trans. Pitch TP	Average Ultimate Strength Lbs Kg-f	Rated Working Load Lbs Kg-f	Number of Links 10ft 5m	Ave. Chain Weight Lbs/ft Kg/m	
			Inside Width W	Dia R	Dia D	Length L1 L2	Height H	Thickness T						
25	inch	0.250	0.125	0.130	0.091	0.15	0.19	0.228	0.030	-	1,040	140	480	0.09
	mm	6.35	3.18	3.30	2.31	3.9	4.7	5.80	0.76	-	473	64	788	0.13
35	inch	0.375	0.188	0.200	0.142	0.23	0.28	0.356	0.050	-	2,400	485	320	0.21
	mm	9.525	4.78	5.08	3.60	5.9	7.0	9.04	1.27	-	1,090	220	526	0.32
35-2	inch					0.44	0.47			0.399	4,800	800		0.42
	mm					11.2	11.9			10.13	2,180	364		0.63
35-3	inch					0.63	0.68			0.39	7,200	1,175		0.63
	mm					16.1	17.2			10.13	3,270	534		0.94
41	inch	0.500	0.246	0.306	0.142	0.26	0.33	0.390	0.049	-	2,600	500	240	0.27
	mm	12.70	6.25	7.77	3.60	6.7	8.5	9.91	1.25	-	1,180	227	394	0.41
40	inch	0.500	0.312	0.312	0.157	0.32	0.41	0.475	0.060	-	4,190	815	240	0.42
	mm	12.70	7.92	7.92	3.98	8.2	10.3	12.06	1.52	-	1,905	370	394	0.62
40-2	inch					0.61	0.69			0.566	8,380	1,375		0.82
	mm					15.5	17.5			14.38	3,810	625		1.22
40-3	inch					0.89	0.97			0.566	12,570	2,000		1.22
	mm					22.6	24.8			14.38	5,715	909		1.82
50	inch	0.625	0.375	0.400	0.200	0.40	0.49	0.594	0.080	-	6,830	1,400	192	0.68
	mm	15.875	9.53	10.16	5.09	10.2	12.4	15.08	2.03	-	3,105	636	316	1.01
50-2	inch					0.76	0.85			0.713	13,670	2,380		1.34
	mm					19.2	21.5			18.11	6,215	1,080		2.00
50-3	inch					1.11	1.21			0.713	20,500	3,500		2.00
	mm					28.3	30.7			18.11	9,320	1,590		2.98
60	inch	0.750	0.500	0.469	0.235	0.50	0.60	0.712	0.094	-	9,260	2,090	160	0.97
	mm	19.05	12.70	11.91	5.96	12.7	15.3	18.09	2.39	-	4,210	950	262	1.45
60-2	inch					0.95	1.05			0.897	18,520	3,300		1.92
	mm					24.1	26.7			22.78	8,420	1,500		2.87
60-3	inch					1.40	1.50			0.897	27,780	4,900		2.87
	mm					35.6	38.2			22.78	12,625	2,225		4.28

ASME/ANSI Standard Roller Chain

Chain Dimensions

MAXCO Chain Number	Units	Chain Pitch P	Roller		Pin			Side Plate		Trans. Pitch TP	Average Ultimate Strength Lbs Kg-f	Rated Working Load Lbs Kg-f	Number of Links 10ft 5m	Ave. Chain Weight Lbs/ft Kg/m
			Inside Width W	Dia R	Dia D	Length		Height H	Thickness T					
						L1	L2							
80	inch	1.000	0.625	0.625	0.313	0.65	0.73	0.950	0.125	-	17,600	3,310	120	1.71
	mm	25.40	15.88	15.88	7.94	16.5	18.5	24.13	3.18	-	8,000	1,505	198	2.55
80-2	inch					1.22	1.31			1.153	35,200	5,500		3.39
	mm					31.1	33.2			29.29	16,000	2,500		5.05
80-3	inch					1.80	1.88			1.153	52,800	8,200		5.06
	mm					45.7	47.8			29.29	24,000	3,725		7.54
100	inch	1.250	0.750	0.750	0.376	0.95	0.95	1.187	0.156	-	23,350	5,070	96	2.65
	mm	31.75	19.05	19.05	9.54	24.1	24.1	30.16	3.96	-	10,615	2,305	158	3.95
100-2	inch					1.66	1.66			1.408	50,700	8,500		5.27
	mm					42.0	42.0			35.76	23,045	3,865		7.86
100-3	inch					2.34	2.34			1.408	76,050	12,500		7.88
	mm					59.4	59.4			35.76	34,570	5,680		11.75
120	inch	1.500	1.000	0.875	0.437	1.01	1.17	1.425	0.187	-	34,390	6,830	80	3.78
	mm	38.10	25.40	22.23	11.11	25.5	29.8	36.19	4.75	-	15,630	3,105	132	5.64
120-2	inch					1.89	2.06			1.789	68,780	11,500		7.51
	mm					48.1	52.3			45.44	31,265	5,225		11.2
120-3	inch					2.77	2.97			1.789	103,170	17,000		15.0
	mm					70.4	75.5			45.44	46,895	7,725		22.3
140	inch	1.750	1.000	1.000	0.500	1.07	1.27	1.662	0.219	-	46,300	9,040	70	4.95
	mm	44.45	25.40	25.40	12.70	27.3	32.2	42.2	5.56	-	21,045	4,110	116	7.38
140-2	inch					2.03	2.24			1.925	92,600	15,000		9.86
	mm					51.6	57.0			48.9	42,090	6,820		14.7
140-3	inch					3.00	3.19			1.925	138,900	22,000		14.7
	mm					76.1	81.1			48.9	63,135	10,000		21.9
160	inch	2.000	1.250	1.125	0.563	1.29	1.46	1.900	0.250	-	57,760	11,900	60	6.30
	mm	50.8	31.75	28.58	14.29	32.8	37.1	48.26	6.35	-	26,255	5,410	98	9.40
160-2	inch					2.46	2.57			2.305	115,520	20,000		12.5
	mm					62.4	65.2			58.6	52,510	9,090		18.6
160-3	inch					3.61	3.69			2.305	173,280	28,000		18.7
	mm					91.8	93.8			58.6	78,765	12,725		27.9
180	inch	2.250	1.406	1.406	0.687	1.44	1.66	2.137	0.281	-	81,000	13,670	54	8.50
	mm	57.15	35.71	35.71	17.46	36.6	42.1	54.29	7.14	-	36,820	6,215	90	12.7
180-2	inch					2.74	2.96			2.591	162,000	22,000		16.9
	mm					69.6	75.1			65.8	73,635	10,000		25.1
180-3	inch					4.03	4.25			2.591	243,000	34,000		25.2
	mm					102.5	108.0			65.8	110,455	15,455		37.6
200	inch	2.500	1.500	1.562	0.781	1.59	1.82	2.375	0.312	-	104,000	16,090	48	10.7
	mm	63.50	38.1	39.68	19.85	40.4	46.4	60.32	7.92	-	47,275	7,315	80	15.9
200-2	inch					3.00	3.23			2.819	208,000	27,000		21.2
	mm					76.2	82.2			71.6	94,545	12,275		31.6
200-3	inch					4.41	4.64			2.819	312,000	40,000		31.7
	mm					111.9	117.9			71.6	141,820	18,180		47.3
240	inch	3.000	1.875	1.875	0.937	1.94	2.18			-	152,000	22,400	40	16.4
	mm	76.20	47.63	47.63	23.81	49.4	55.4			-	69,090	10,180	66	24.4
240-2	inch					3.67	3.91			3.457	304,000	37,000		32.5
	mm					93.3	99.2			87.8	138,180	16,820		48.4
240-3	inch					5.40	5.64			3.457	456,000	54,500		48.6
	mm					137.2	143.2			87.8	207,275	24,775		72.4

ISO 606B British Standard Roller Chain

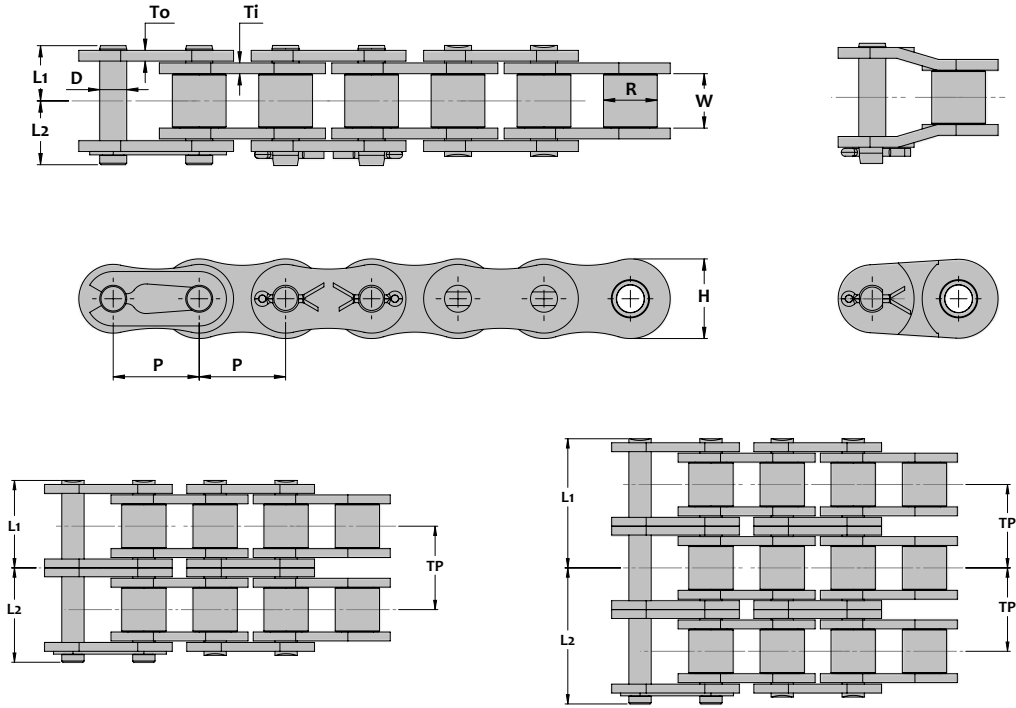

Chain Dimensions

MAXCO Chain Number	Units	Chain Pitch P	Roller		Pin			Side Plate			Trans. Pitch TP	Average Ultimate Strength Lbs Kg-f	Rated Working Load Lbs Kg-f	Number of Links 10ft 5m	Average Chain Weight Lbs/ft Kg/m
			Inside Width W	Dia R	Dia D	Length L1	L2	Height H	Thickness To Ti						
05B	inch	0.315	0.118	0.197	0.091	0.15	0.19	.280	0.031		-	1,280	245	382	0.11
	mm	8.0	3.00	5.00	2.31	3.9	4.7	7.11	0.78		-	582	111	626	0.16
06B	inch	0.375	0.225	0.250	0.129	0.24	0.28	0.325	0.039	0.050	-	2,150	400	320	0.27
	mm	9.53	5.72	6.35	3.28	6.1	7.1	8.26	1.00	1.28	-	975	182	526	0.41
06B-2	inch					0.44	0.50				0.403	4,280	660		0.50
	mm					11.3	12.7				10.24	1,945	300		0.74
06B-3	inch					0.65	0.70				0.403	6,280	950		0.74
	mm					16.4	17.7				10.24	2,855	432		1.10
08B	inch	0.500	0.335	0.305	0.175	0.32	0.37	0.465	0.059	0.062	-	4,230	710	240	0.44
	mm	12.7	8.51	7.75	4.45	8.2	9.3	11.81	1.49	1.58	-	1,925	323	394	0.66
08B-2	inch					0.61	0.67				0.548	7,700	1,210		0.87
	mm					15.5	17.1				13.92	3,500	550		1.30
08B-3	inch					0.89	0.95				0.548	11,000	1,770		1.31
	mm					22.6	24.1				13.92	5,000	805		1.95
10B	inch	0.625	0.400	0.380	0.200	0.39	0.45	0.580	0.67		-	5,500	1,100	192	0.62
	mm	15.88	10.16	9.65	5.08	9.9	11.6	14.73	1.71		-	2,500	500	316	0.92
10B-2	inch					0.71	1.11				0.653	11,000	1,870		1.21
	mm					18.0	28.2				16.59	5,000	850		1.81
10B-3	inch					1.05	1.11				0.653	16,000	2,750		1.81
	mm					26.6	28.1				16.59	7,275	1,250		2.70

ISO 606B British Standard Roller Chain

Chain Dimensions

MAXCO Chain Number	Units	Chain Pitch P	Roller			Pin			Side Plate			Trans. Pitch TP	Average Ultimate Strength Lbs Kg-f	Rated Working Load Lbs Kg-f	Number of Links 10ft 5m	Average Chain Weight Lbs/ft Kg/m
			Inside Width W	Dia R	Dia D	Length		Height H	Thickness							
						L1	L2		To	Ti						
12B	inch	0.750	0.475	0.460	0.225	0.44	0.57	0.635	0.073		-	7,100	1,540	160	0.81	
	mm	19.05	12.07	11.68	5.72	11.3	14.6	16.13	1.86		-	3,225	700	262	1.21	
12B-2	inch					0.84	0.95				0.766	14,200	2,650		1.61	
	mm					21.2	24.0				19.46	6,455	1,205		2.40	
12B-3	inch					1.22	1.34				0.766	21,300	3,860		2.41	
	mm					31.0	34.0				19.46	9,680	1,755		3.59	
16B	inch	1.000	0.625	0.670	0.326	0.71	0.83	0.830	0.125	0.157	-	15,000	3,530	120	1.78	
	mm	25.4	15.88	17.02	8.28	18.1	21.1	21.08	3.18	3.99	-	6,820	1,605	198	2.66	
16B-2	inch					1.34	1.41				1.255	30,000	4,800		3.53	
	mm					34.1	35.8				31.88	13,635	2,180		5.27	
16B-3	inch					1.97	2.10				1.255	45,000	7,000		5.28	
	mm					50.1	53.5				31.88	20,455	3,180		7.88	
20B	inch	1.250	0.750	0.770	0.401	0.79	0.96	1.040	0.125	0.176	-	23,150	4,190	96	2.43	
	mm	31.75	19.05	19.56	10.19	20.1	24.4	26.42	3.18	4.46	-	10,525	1,905	158	3.62	
20B-2	inch					1.51	1.66				1.435	46,300	7,170		4.80	
	mm					38.4	42.2				36.45	21,045	3,260		7.16	
20B-3	inch					2.23	2.41				1.435	69,450	10,470		7.21	
	mm					58.6	61.2				36.45	31,570	4,760		10.8	
24B	inch	1.500	1.000	1.000	0.576	1.07	1.27	1.315	0.189	0.236	-	36,680	7,050	80	4.73	
	mm	38.1	25.4	25.4	14.63	27.1	32.2	33.4	4.80	6.00	-	16,675	3,205	132	7.05	
24B-2	inch					2.00	2.24				1.904	79,370	10,520		9.39	
	mm					50.9	56.8				48.36	36,075	4,780		14.0	
24B-3	inch					2.97	3.18				1.904	119,050	15,540		13.9	
	mm					75.4	80.7				48.36	54,115	7,030		20.7	
28B	inch	1.750	1.100	1.220	0.626	1.30	1.47	1.460	0.236	0.287	-	50,000	9,920	70	6.42	
	mm	44.45	27.94	30.99	15.90	33.0	37.5	37.08	6.00	7.30	-	22,725	4,510	116	9.58	
28B-2	inch					2.47	2.66				2.345	94,000	13,100		12.7	
	mm					62.7	67.5				59.56	42,725	5,955		19.0	
28B-3	inch					3.64	3.83				2.345	139,000	19,290		19.0	
	mm					92.5	97.3				59.56	63,180	8,770		28.3	
32B	inch	2.000	1.150	1.220	0.701	1.31	1.50	1.665	0.236	0.276	-	61,000	10,580	60	6.18	
	mm	50.8	29.21	30.99	17.81	33.2	38.2	42.29	6.00	7.00	-	27,725	4,810	98	9.22	
32B-2	inch					2.46	2.66				2.305	121,500	14,970		12.4	
	mm					62.4	67.5				58.55	55,225	6,805		18.4	
32B-3	inch					3.61	3.81				2.305	181,000	22,030		18.5	
	mm					91.7	96.7				58.55	82,275	10,015		27.6	
40B	inch	2.500	1.550	1.500	0.901	1.63	2.03	2.085	0.315	0.323	-	93,500	15,210	48	10.9	
	mm	63.5	39.37	38.1	22.89	41.3	51.5	52.96	8.00	8.20	-	42,500	6,915	80	16.3	
40B-2	inch					3.05	3.45				2.846	187,000	25,790		21.5	
	mm					77.5	87.7				72.29	85,000	11,725		32.0	
40B-3	inch					4.47	4.87				2.846	280,500	38,030		31.9	
	mm					113.6	123.8				72.29	127,500	17,285		47.5	
48B	inch	3.000	1.900	1.800	1.151	1.95	2.36	2.515	0.374	0.472	-	141,000	23,150	40	16.8	
	mm	76.2	48.26	45.72	29.24	49.6	60.1	63.88	9.50	12.0	-	64,090	10,525	66	25.0	
48B-2	inch					3.75	4.16				2.846	282,000	39,350		33.5	
	mm					95.2	105.7				72.29	128,180	17,885		50.0	
48B-3	inch					5.54	5.96				2.846	423,000	57,870		50.3	
	mm					140.8	151.3				72.29	192,275	26,305		75.0	

ASME/ANSI Heavy (H) Series Roller Chain

Heavy Series roller chains are built for power transmission applications that require additional shock load capacity or link plate strength. They are dimensionally equivalent to ASME/ANSI standard chains except that link plates are one size thicker. Single strand chains operate on standard sprockets however multiple strand chains require special sprockets due to their increased transverse pitch.

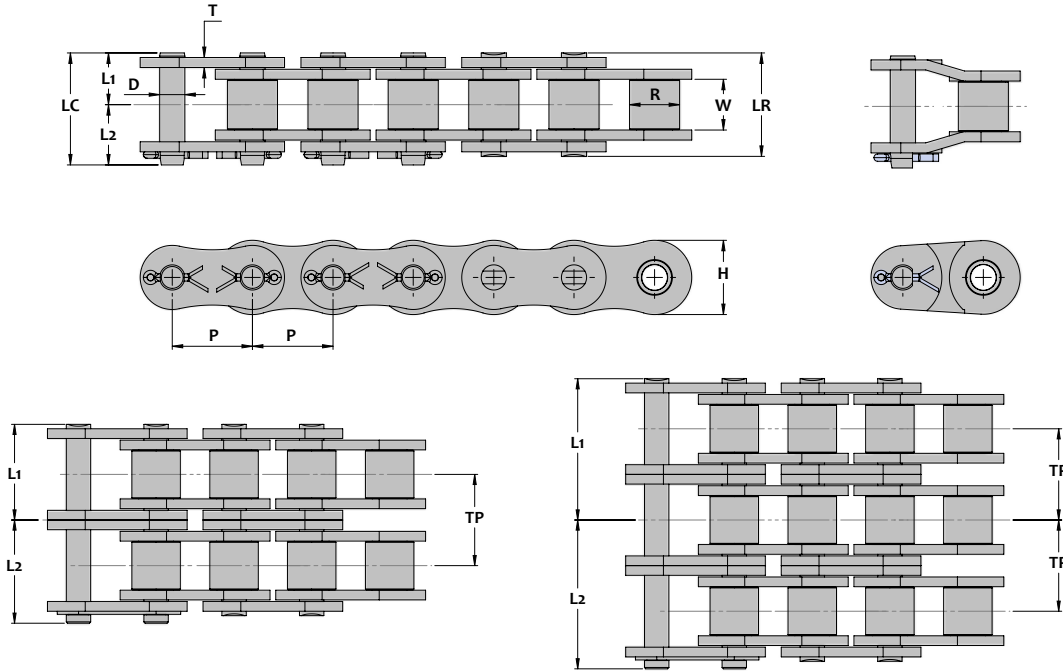

Chain Dimensions - Single Strand

MAXCO Chain Number	Units	Chain Pitch P	Roller			Pin				Side Plate		Average Ultimate Strength Lbs Kg-f	Average Chain Weight Lbs/ft Kg/m
			Dia	Inside Width	Dia	Length			Height	Thick.			
			R	W	D	L1	L2	LR	LC	H	T		
50H	inch	0.625	0.400	0.375	0.200	0.44	0.53	0.87	0.96	0.594	0.094	8,150	0.76
	mm	15.88	10.16	9.52	5.09	11.1	13.4	22.1	24.4	15.08	2.39	3,705	1.14
60H	inch	0.750	0.469	0.500	0.235	0.57	0.67	1.13	1.21	0.712	0.125	11,900	1.16
	mm	19.05	11.91	12.70	5.96	14.4	16.9	28.8	30.8	18.09	3.18	5,410	1.73
80H	inch	1.000	0.625	0.625	0.313	0.71	0.89	1.43	1.60	0.950	0.156	20,300	1.99
	mm	25.40	15.88	15.88	7.94	18.2	22.6	36.3	40.7	24.13	3.96	9,225	2.97
100H	inch	1.250	0.750	0.750	0.376	0.86	1.00	1.72	1.86	1.187	0.187	30,400	3.01
	mm	31.75	19.05	19.05	9.54	21.8	25.3	43.7	47.2	30.2	4.75	13,820	4.49
120H	inch	1.500	0.875	1.000	0.437	1.07	1.26	2.14	2.34	1.425	0.219	41,000	4.20
	mm	38.10	22.23	25.40	11.11	27.2	32.1	54.5	59.4	36.2	5.56	18,635	6.26
140H	inch	1.750	1.000	1.000	0.500	1.14	1.35	2.29	2.49	1.662	0.250	54,000	5.47
	mm	44.45	25.40	25.40	12.71	29.1	34.2	58.1	63.2	42.2	6.35	24,545	8.15
160H	inch	2.000	1.125	1.250	0.563	1.34	1.55	2.68	2.88	1.900	0.281	68,000	7.09
	mm	50.80	28.58	31.75	14.29	34.0	39.3	68.0	73.3	48.26	7.14	30,910	10.6
180H	inch	2.250	1.406	1.406	0.687	1.52	1.74	3.04	3.26	2.137	0.312	83,000	9.19
	mm	57.15	35.71	35.71	17.46	38.6	44.1	77.3	82.8	54.29	7.92	37,725	13.7
200H	inch	2.500	1.562	1.500	0.781	1.72	1.93	3.43	3.65	2.375	0.375	113,800	12.8
	mm	63.50	39.67	38.10	19.85	43.6	49.1	87.1	92.7	60.32	9.53	51,725	19.1

ASME/ANSI Heavy (H) Series Roller Chain

Chain Dimensions - Double Strand

MAXCO Chain Number	Units	Chain Pitch P	Roller			Pin				Side Plate		Trans. Pitch TP	Average Ultimate Strength Lbs Kg-f	Average Chain Weight Lbs/ft Kg/m
			Dia	Inside Width	Dia	Length				Height	Thick.			
			R	W	D	L1	L2	LR	LC	H	T			
60H-2	inch	0.750	0.469	0.500	0.235	1.08	1.17	2.17	2.26	0.712	0.125	1.028	23,800	2.30
	mm	19.05	11.91	12.70	5.96	27.6	29.8	55.1	57.3	18.09	3.18	26.11	10,820	3.43
80H-2	inch	1.000	0.625	0.625	0.313	1.37	1.52	2.74	2.89	0.950	0.156	1.283	40,600	3.96
	mm	25.40	15.88	15.88	7.94	34.8	38.7	69.5	73.4	24.13	3.96	32.59	18,455	5.91
100H-2	inch	1.250	0.750	0.750	0.376	1.64	1.76	3.27	3.40	1.187	0.187	1.539	60,800	5.87
	mm	31.75	19.05	19.05	9.54	41.6	44.8	83.2	86.4	30.2	4.75	39.09	27,635	8.75
120H-2	inch	1.500	0.875	1.000	0.437	2.05	2.23	4.10	4.28	1.425	0.219	1.924	82,000	8.38
	mm	38.10	22.23	25.40	11.11	52.0	56.7	104.1	108.8	36.2	5.56	48.87	37,275	12.5
140H-2	inch	1.750	1.000	1.000	0.500	2.17	2.37	4.34	4.54	1.662	0.250	2.055	108,000	10.9
	mm	44.45	25.40	25.40	12.71	55.2	60.2	110.3	115.3	42.2	6.35	52.20	49,090	16.2
160H-2	inch	2.000	1.125	1.250	0.563	2.56	2.76	5.11	5.32	1.900	0.281	2.437	136,000	14.1
	mm	50.80	28.58	31.75	14.29	65.0	70.2	129.9	135.2	48.26	7.14	61.90	61,820	21.1
180H-2	inch	2.250	1.406	1.406	0.687	2.88	3.35	5.76	6.23	2.137	0.312	2.723	166,000	18.2
	mm	57.15	35.71	35.71	17.46	73.2	85.0	146.4	158.2	54.29	7.92	69.16	75,455	27.1
200H-2	inch	2.500	1.562	1.500	0.781	3.26	3.48	6.51	6.73	2.375	0.375	3.083	227,600	25.4
	mm	63.50	39.67	38.10	19.85	82.7	88.3	165.4	171.0	60.32	9.53	78.31	103,455	37.9

Chain Dimensions - Triple Strand

MAXCO Chain Number	Units	Chain Pitch P	Roller			Pin				Side Plate		Trans. Pitch TP	Average Ultimate Strength Lbs Kg-f	Average Chain Weight Lbs/ft Kg/m
			Dia	Inside Width	Dia	Length				Height	Thick.			
			R	W	D	L1	L2	LR	LC	H	T			
60H-3	inch	0.750	0.469	0.500	0.235	1.60	1.69	3.20	3.28	0.712	0.125	1.028	35,700	3.43
	mm	19.05	11.91	12.70	5.96	40.6	42.8	81.2	83.4	18.09	3.18	26.11	16,225	5.11
80H-3	inch	1.000	0.625	0.625	0.313	2.01	2.16	4.02	4.17	0.950	0.156	1.283	60,900	5.89
	mm	25.40	15.88	15.88	7.94	51.0	54.9	102.1	106.0	24.13	3.96	32.59	27,680	8.78
100H-3	inch	1.250	0.750	0.750	0.376	2.41	2.53	4.81	4.94	1.187	0.187	1.539	91,200	8.72
	mm	31.75	19.05	19.05	9.54	61.1	64.3	122.3	125.4	30.2	4.75	39.09	41,455	13.0
120H-3	inch	1.500	0.875	1.000	0.437	3.01	3.20	6.02	6.21	1.425	0.219	1.924	123,000	12.6
	mm	38.10	22.23	25.40	11.11	76.5	81.2	152.9	157.6	36.2	5.56	48.87	55,910	18.7
140H-3	inch	1.750	1.000	1.000	0.500	3.20	3.40	6.40	6.60	1.662	0.250	2.055	162,000	16.3
	mm	44.45	25.40	25.40	12.71	81.3	86.3	162.5	167.5	42.2	6.35	52.20	73,635	24.3
160H-3	inch	2.000	1.125	1.250	0.563	3.78	3.98	7.55	7.76	1.900	0.281	2.437	204,000	21.1
	mm	50.80	28.58	31.75	14.29	95.9	101.2	191.8	197.1	48.26	7.14	61.90	92,725	31.4
180H-3	inch	2.250	1.406	1.406	0.687	4.24	4.71	8.49	8.95	2.137	0.312	2.723	249,000	27.2
	mm	57.15	35.71	35.71	17.46	107.8	119.6	215.6	227.4	54.29	7.92	69.16	113,180	40.5
200H-3	inch	2.500	1.562	1.500	0.781	4.80	5.02	9.60	9.82	2.375	0.375	3.083	341,400	38.0
	mm	63.50	39.67	38.10	19.85	121.9	127.4	243.8	249.3	60.32	9.53	78.31	155,180	56.7

ASME/ANSI Through Hardened Pin (E) Series Roller Chain

E-Series roller chains possess alloy steel through hardened pins to significantly improve shock load resistance and increase ultimate strength. These chains are often used on heavy construction or mining equipment when superior toughness is required. E-series roller chains operate on standard ASME/ANSI sprockets . . . Hardened teeth are recommended.

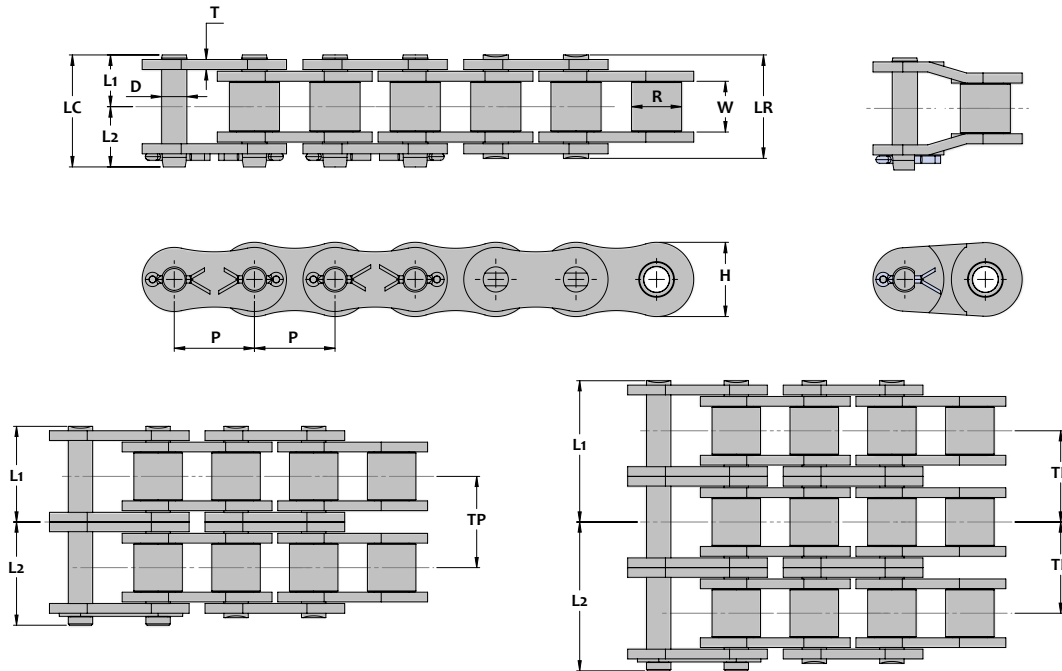

Chain Dimensions - Single Strand

MAXCO Chain Number	Units	Chain Pitch P	Roller			Pin				Side Plate		Average Ultimate Strength Lbs Kg-f	Average Chain Weight Lbs/ft Kg/m
			Dia	Inside Width	Dia	Length				Height	Thick.		
			R	W	D	L1	L2	LR	LC	H	T		
50E	inch	0.625	0.400	0.375	0.200	0.40	0.49	0.80	0.89	0.594	0.080	7,050	0.72
	mm	15.88	10.16	9.52	5.09	10.2	12.4	20.3	22.6	15.08	2.03	3,205	1.08
60E	inch	0.750	0.469	0.500	0.235	0.50	0.60	1.00	1.10	0.712	0.125	9,700	1.04
	mm	19.05	11.91	12.70	5.96	12.7	15.3	25.4	28.0	18.09	2.39	4,410	1.55
80E	inch	1.000	0.625	0.625	0.313	0.65	0.80	1.30	1.45	0.950	0.125	17,700	1.82
	mm	25.40	15.88	15.88	7.94	16.5	20.4	33.0	36.9	24.13	3.18	8,045	2.71
100E	inch	1.250	0.750	0.750	0.376	0.78	0.95	1.56	1.73	1.187	0.156	26,500	2.76
	mm	31.75	19.05	19.05	9.54	19.8	24.1	39.7	44.0	30.2	3.96	12,045	4.11
120E	inch	1.500	0.875	1.000	0.437	1.01	1.17	2.01	2.18	1.425	0.187	39,000	4.02
	mm	38.10	22.23	25.40	11.11	25.5	29.8	51.1	55.4	36.2	4.75	17,725	5.99
140E	inch	1.750	1.000	1.000	0.500	1.07	1.27	2.15	2.34	1.662	0.219	50,500	5.16
	mm	44.45	25.40	25.40	12.71	27.3	32.2	54.5	59.4	42.2	5.56	22,955	7.70
160E	inch	2.000	1.125	1.250	0.563	1.29	1.46	2.58	2.75	1.900	0.250	66,000	6.50
	mm	50.80	28.58	31.75	14.29	32.8	37.1	65.5	69.8	48.26	6.35	30,000	9.69
180E	inch	2.250	1.406	1.406	0.687	1.44	1.66	2.89	3.10	2.137	0.281	81,500	8.92
	mm	57.15	35.71	35.71	17.46	36.6	42.1	73.3	78.8	54.29	7.14	37,045	13.3
200E	inch	2.500	1.562	1.500	0.781	1.59	1.82	3.18	3.41	2.375	0.312	105,000	11.4
	mm	63.50	39.67	38.10	19.85	40.4	46.4	80.7	86.7	60.32	7.92	47,725	17.0

ASME/ANSI Through Hardened Pin (E) Series Roller Chain

Chain Dimensions - Double Strand

MAXCO Chain Number	Units	Chain Pitch P	Roller			Pin				Side Plate		Trans. Pitch TP	Average Ultimate Strength Lbs Kg-f	Average Chain Weight Lbs/ft Kg/m
			Dia	Inside Width	Dia	Length				Height	Thick.			
			R	W	D	L1	L2	LR	LC	H	T			
60E-2	inch	0.750	0.469	0.500	0.235	0.95	1.05	1.90	2.00	0.712	0.125	0.897	19,400	2.07
	mm	19.05	11.91	12.70	5.96	24.1	26.7	48.2	50.8	18.09	2.39	22.78	882	3.09
80E-2	inch	1.000	0.625	0.625	0.313	1.23	1.38	2.45	2.61	0.950	0.125	1.153	35,400	3.62
	mm	25.40	15.88	15.88	7.94	31.2	35.1	62.3	66.2	24.13	3.18	29.29	16,090	5.40
100E-2	inch	1.250	0.750	0.750	0.376	1.49	1.65	2.97	3.14	1.187	0.156	1.408	53,000	5.47
	mm	31.75	19.05	19.05	9.54	37.7	42.0	75.4	79.7	30.2	3.96	35.76	24,090	8.15
120E-2	inch	1.500	0.875	1.000	0.437	1.90	2.07	3.80	3.97	1.425	0.187	1.789	78,000	7.99
	mm	38.10	22.23	25.40	11.11	48.3	52.6	96.5	100.8	36.2	4.75	45.44	35,455	11.91
140E-2	inch	1.750	1.000	1.000	0.500	2.04	2.23	4.07	4.26	1.662	0.219	1.924	101,000	10.29
	mm	44.45	25.40	25.40	12.71	51.7	56.6	103.4	108.3	42.2	5.56	48.87	45,910	15.35
160E-2	inch	2.000	1.125	1.250	0.563	2.44	2.61	4.89	5.05	1.900	0.250	2.305	132,000	12.89
	mm	50.80	28.58	31.75	14.29	62.0	66.3	124.1	128.4	48.26	6.35	58.55	60,000	19.23
180E-2	inch	2.250	1.406	1.406	0.687	2.74	2.96	5.48	5.69	2.137	0.281	2.592	163,000	17.71
	mm	57.15	35.71	35.71	17.46	69.6	75.1	139.1	144.6	54.29	7.14	65.84	74,090	26.41
200E-2	inch	2.500	1.562	1.500	0.781	3.00	3.23	5.99	6.23	2.375	0.312	2.817	210,000	22.76
	mm	63.50	39.67	38.10	19.85	76.1	82.1	152.3	158.3	60.32	7.92	71.55	95,455	33.94

Chain Dimensions - Triple Strand

MAXCO Chain Number	Units	Chain Pitch P	Roller			Pin				Side Plate		Trans. Pitch TP	Average Ultimate Strength Lbs Kg-f	Average Chain Weight Lbs/ft Kg/m
			Dia	Inside Width	Dia	Length				Height	Thick.			
			R	W	D	L1	L2	LR	LC	H	T			
60E-3	inch	0.750	0.469	0.500	0.235	1.40	1.50	2.80	2.90	0.712	0.125	0.897	29,100	3.10
	mm	19.05	11.91	12.70	5.96	35.5	38.1	71.0	73.6	18.09	2.39	22.78	13,225	4.62
80E-3	inch	1.000	0.625	0.625	0.313	1.80	1.96	3.61	3.76	0.950	0.125	1.153	53,100	5.42
	mm	25.40	15.88	15.88	7.94	45.8	49.7	91.6	95.5	24.13	3.18	29.29	24,135	8.08
100E-3	inch	1.250	0.750	0.750	0.376	2.19	2.36	5.59	5.76	1.187	0.156	1.408	79,500	8.19
	mm	31.75	19.05	19.05	9.54	55.6	59.9	111.2	115.5	30.2	3.96	35.76	36,135	12.2
120E-3	inch	1.500	0.875	1.000	0.437	2.79	2.96	5.59	5.76	1.425	0.187	1.789	117,000	11.9
	mm	38.10	22.23	25.40	11.11	71.0	75.3	141.9	146.2	36.2	4.75	45.44	53,180	17.8
140E-3	inch	1.750	1.000	1.000	0.500	3.00	3.19	6.00	6.19	1.662	0.219	1.924	151,500	15.4
	mm	44.45	25.40	25.40	12.71	76.1	81.0	152.3	157.2	42.2	5.56	48.87	68,865	23.0
160E-3	inch	2.000	1.125	1.250	0.563	3.59	3.76	7.19	7.36	1.900	0.250	2.305	198,000	19.3
	mm	50.80	28.58	31.75	14.29	91.3	95.6	182.6	186.9	48.26	6.35	58.55	90,000	28.8
180E-3	inch	2.250	1.406	1.406	0.687	4.03	4.25	8.07	8.29	2.137	0.281	2.592	244,500	26.5
	mm	57.15	35.71	35.71	17.46	102.5	108.0	205.0	210.5	54.29	7.14	65.84	111,135	39.5
200E-3	inch	2.500	1.562	1.500	0.781	4.41	4.64	8.81	9.05	2.375	0.312	2.817	315,000	34.1
	mm	63.50	39.67	38.10	19.85	111.9	117.9	223.8	229.8	60.32	7.92	71.55	143,180	50.9

ISO British Standard Through Hardened Pin (E) Roller Chain

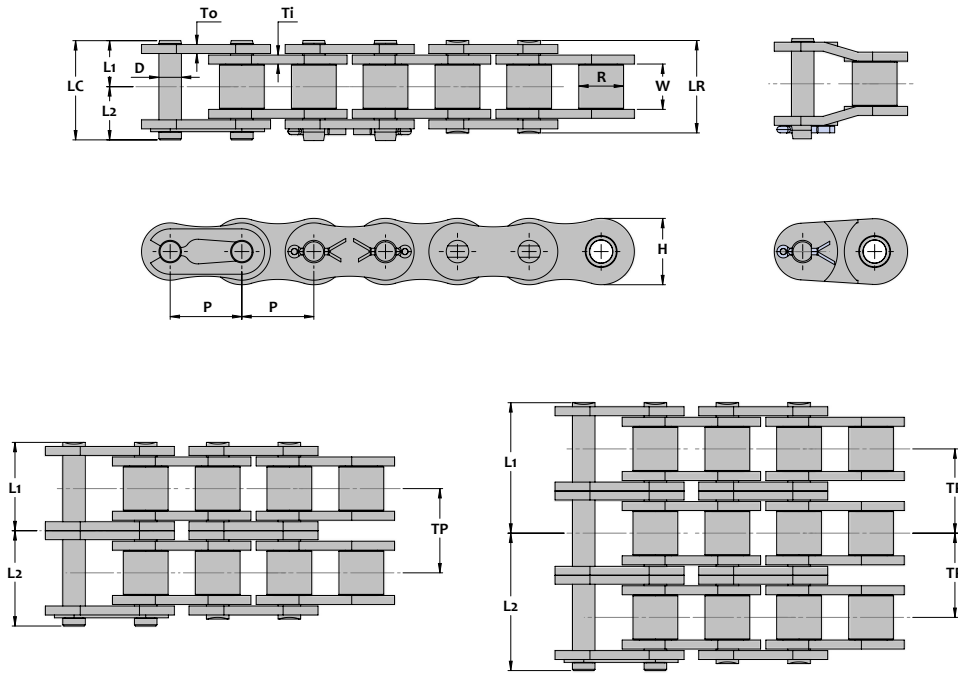

Chain Dimensions - Single Strand

MAXCO Chain Number	Units	Chain Pitch P	Roller			Pin				Side Plate		Average Ultimate Strength Lbs Kg-f	Average Chain Weight Lbs/ft Kg/m	
			Dia R	Inside Width W	Dia D	Length				Height H	Thickness			
						L1	L2	LR	LC		To			Ti
10BE	inch	0.625	0.400	0.380	0.200	0.39	0.48	0.78	0.87	0.580	0.067	6,390	0.66	
	mm	15.88	10.16	9.65	5.08	9.9	12.3	19.7	22.1	14.73	1.71	2,905	0.98	
12BE	inch	0.750	0.475	0.460	0.225	0.44	0.57	0.89	1.02	0.635	0.073	7,390	0.84	
	mm	19.05	12.07	11.68	5.72	11.3	14.6	22.5	25.8	16.13	1.86	3,360	1.25	
16BE	inch	1.000	0.625	0.670	0.326	0.71	0.83	1.43	1.54	0.830	0.125	0.157	17,640	1.90
	mm	25.40	15.88	17.02	8.28	18.1	21.1	36.2	39.2	21.08	3.18	3.99	8,020	2.83
20BE	inch	1.250	0.750	0.770	0.400	0.79	0.96	1.58	1.75	1.040	0.125	0.176	26,680	2.62
	mm	31.75	19.05	19.56	10.19	20.1	24.4	40.2	44.5	26.42	3.18	4.46	12,125	3.90
24BE	inch	1.500	1.000	1.000	0.576	1.07	1.27	2.13	2.33	1.315	0.189	0.236	43,210	4.83
	mm	38.10	25.40	25.40	14.63	27.1	32.2	54.1	59.2	33.40	4.80	6.00	19,640	7.21
28BE	inch	1.750	1.100	1.220	0.626	1.30	1.47	2.59	2.77	1.460	0.236	0.287	59,300	6.42
	mm	44.45	27.94	30.99	15.90	33.0	37.5	65.9	70.4	37.08	6.00	7.30	26,955	9.58
32BE	inch	2.000	1.150	1.220	0.701	1.31	1.50	2.61	2.81	1.665	0.236	0.276	65,920	6.69
	mm	50.80	29.21	30.99	17.81	33.2	38.2	66.3	71.3	42.29	6.00	7.00	29,965	9.97
40BE	inch	2.500	1.550	1.500	0.900	1.63	2.03	3.25	3.65	2.085	0.315	0.323	93,700	10.9
	mm	63.50	39.37	38.10	22.89	41.3	51.5	82.6	92.8	52.96	8.00	8.20	42,590	16.3
48BE	inch	3.000	1.900	1.800	1.150	1.95	2.36	3.90	4.31	2.515	0.374	0.472	141,100	16.8
	mm	76.20	48.26	45.72	29.24	49.6	60.1	99.1	109.6	63.88	9.50	12.0	64,135	25.0

ISO British Standard Through Hardened Pin (E) Roller Chain

Chain Dimensions - Double Strand

MAXCO Chain Number	Units	Chain Pitch P	Roller		Pin					Side Plate		Trans. Pitch TP	Average Ultimate Strength Lbs Kg-f	Average Chain Weight Lbs/ft Kg/m	
			Dia	Inside Width W	Dia	Length				Height	Thickness				
			R	D	L1	L2	LR	LC	H	To	Ti				
12BE-2	inch	0.750	0.475	0.460	0.225	0.84	0.95	1.67	1.78	0.635	0.073		0.766	14,770	1.54
	mm	19.05	12.07	11.68	5.72	21.2	24.0	42.5	45.3	16.13	1.86		19.46	6,715	2.30
16BE-2	inch	1.000	0.625	0.670	0.326	1.34	1.41	2.69	2.75	0.830	0.125	0.157	1.255	35,270	3.55
	mm	25.40	15.88	17.02	8.28	34.1	35.8	68.2	69.9	21.08	3.18	3.99	31.88	16,030	5.30
20BE-2	inch	1.250	0.750	0.770	0.400	1.51	1.66	3.02	3.17	1.040	0.125	0.176	1.435	53,350	4.87
	mm	31.75	19.05	19.56	10.19	38.4	42.2	76.8	80.6	26.42	3.18	4.46	38.45	24,250	7.26
24BE-2	inch	1.500	1.000	1.000	0.576	2.00	2.24	4.01	4.24	1.315	0.189	0.236	1.904	86,420	9.39
	mm	38.10	25.40	25.40	14.63	50.9	56.8	101.7	107.6	33.40	4.80	6.00	48.36	39,280	14.0
28BE-2	inch	1.750	1.100	1.220	0.626	2.47	2.66	4.94	5.13	1.460	0.236	0.287	2.345	118,610	12.1
	mm	44.45	27.94	30.99	15.90	62.7	67.5	125.4	130.2	37.08	6.00	7.30	59.56	53,915	18.1
32BE-2	inch	2.000	1.150	1.220	0.701	2.46	2.66	4.91	5.11	1.665	0.236	0.276	2.305	131,840	13.8
	mm	50.80	29.21	30.99	17.81	62.4	67.5	124.8	129.9	42.29	6.00	7.00	58.55	59,925	20.5
40BE-2	inch	2.500	1.550	1.500	0.900	3.05	3.45	6.10	6.50	2.085	0.315	0.323	2.846	187,390	21.5
	mm	63.50	39.37	38.10	22.89	77.5	87.7	154.9	165.1	52.96	8.00	8.20	72.29	85,175	32.0
48BE-2	inch	3.000	1.900	1.800	1.150	3.75	4.16	7.50	7.91	2.515	0.374	0.472	3.591	282,190	33.5
	mm	76.20	48.26	45.72	29.24	95.2	105.7	190.4	200.9	63.88	9.50	12.0	91.21	128,270	50.0

Chain Dimensions - Triple Strand

MAXCO Chain Number	Units	Chain Pitch P	Roller		Pin					Side Plate		Trans. Pitch TP	Average Ultimate Strength Lbs Kg-f	Average Chain Weight Lbs/ft Kg/m	
			Dia	Inside Width W	Dia	Length				Height	Thickness				
			R	D	L1	L2	LR	LC	H	To	Ti				
12BE-3	inch	0.750	0.475	0.460	0.225	1.22	1.34	2.44	2.56	0.635	0.073		0.766	22,160	2.28
	mm	19.05	12.07	11.68	5.72	31.0	34.0	62.0	65.0	16.13	1.86		19.46	10,075	3.40
16BE-3	inch	1.000	0.625	0.670	0.326	1.97	2.10	3.94	4.08	0.830	0.125	0.157	1.255	52,910	5.16
	mm	25.40	15.88	17.02	8.28	50.1	53.5	100.1	103.5	21.08	3.18	3.99	31.88	24,050	7.70
20BE-3	inch	1.250	0.750	0.770	0.400	2.23	2.41	4.46	4.64	1.040	0.125	0.176	1.435	80,030	7.28
	mm	31.75	19.05	19.56	10.19	56.6	61.2	113.2	117.8	26.42	3.18	4.46	38.45	36,375	10.9
24BE-3	inch	1.500	1.000	1.000	0.576	2.97	3.18	5.93	6.14	1.315	0.189	0.236	1.904	129,630	14.1
	mm	38.10	25.40	25.40	14.63	75.4	80.7	150.7	156.0	33.40	4.80	6.00	48.36	58,925	21.0
28BE-3	inch	1.750	1.100	1.220	0.626	3.64	3.83	7.28	7.47	1.460	0.236	0.287	2.345	177,910	17.8
	mm	44.45	27.94	30.99	15.90	92.5	97.3	185.0	189.8	37.08	6.00	7.30	59.56	80,870	26.6
32BE-3	inch	2.000	1.150	1.220	0.701	3.61	3.81	7.22	7.42	1.665	0.236	0.276	2.305	197,750	21.5
	mm	50.80	29.21	30.99	17.81	91.7	96.7	183.4	188.4	42.29	6.00	7.00	58.55	89,885	32.0
40BE-3	inch	2.500	1.550	1.500	0.900	4.47	4.87	8.94	9.35	2.085	0.315	0.323	2.846	281,090	31.9
	mm	63.50	39.37	38.10	22.89	113.6	123.8	227.2	237.4	52.96	8.00	8.20	72.29	127,770	47.5
48BE-3	inch	3.000	1.900	1.800	1.150	5.54	5.96	11.09	11.50	2.515	0.374	0.472	3.591	423,290	50.3
	mm	76.20	48.26	45.72	29.24	140.8	151.3	281.6	292.1	63.88	9.50	12.0	91.21	192,405	75.0

ASME/ANSI Heavy-Through Hardened Pin (HE) Roller Chain

HE-Series roller chains possess alloy steel through hardened pins and one size thicker link plates for maximum toughness. A combination of the features found in the Heavy (H-Series) and E-Series chains provide reliable performance in the toughest applications. Single strand chains operate over standard ASME/ANSI sprockets (hardened teeth recommended), however multiple strand chains require special sprockets due to their increased transverse pitch.

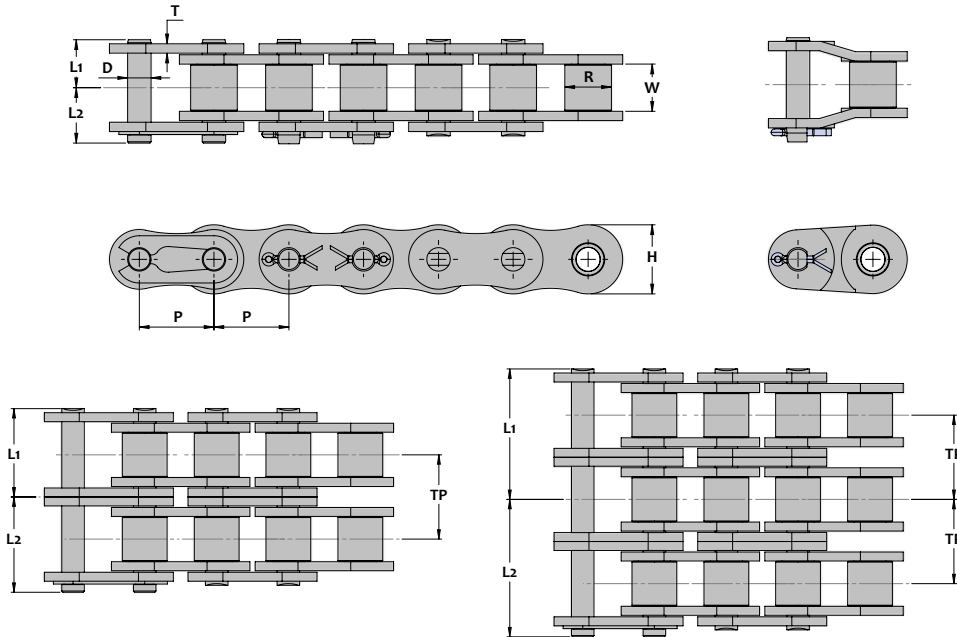

Chain Dimensions - Single Strand

MAXCO Chain Number	Units	Chain Pitch P	Roller			Pin				Side Plate		Average Ultimate Strength Lbs Kg-f	Average Chain Weight Lbs/ft Kg/m
			Dia	Inside Width	Dia	Length				Height	Thick.		
			R	W	D	L1	L2	LR	LC	H	T		
50HE	inch	0.625	0.400	0.375	0.200	0.44	0.53	0.87	0.96	0.594	0.080	8,820	0.76
	mm	15.88	10.16	9.52	5.09	11.1	13.4	22.1	24.4	15.08	2.03	4,010	1.14
60HE	inch	0.750	0.469	0.500	0.235	0.57	0.67	1.13	1.21	0.712	0.125	12,150	1.16
	mm	19.05	11.91	12.70	5.96	14.4	16.9	28.8	30.8	18.09	2.39	5,525	1.73
80HE	inch	1.000	0.625	0.625	0.313	0.71	0.89	1.43	1.60	0.950	0.125	21,800	1.99
	mm	25.40	15.88	15.88	7.94	18.2	22.6	36.3	40.7	24.13	3.18	9,910	2.97
100HE	inch	1.250	0.750	0.750	0.376	0.86	1.00	1.72	1.86	1.187	0.156	31,000	3.01
	mm	31.75	19.05	19.05	9.54	21.8	25.3	43.7	47.2	30.2	3.96	14,090	4.49
120HE	inch	1.500	0.875	1.000	0.437	1.07	1.26	2.14	2.34	1.425	0.187	42,000	4.20
	mm	38.10	22.23	25.40	11.11	27.2	32.1	54.5	59.4	36.2	4.75	19,090	6.26
140HE	inch	1.750	1.000	1.000	0.500	1.14	1.35	2.29	2.49	1.662	0.219	55,000	5.47
	mm	44.45	25.40	25.40	12.71	29.1	34.2	58.1	63.2	42.2	5.56	25,000	8.15
160HE	inch	2.000	1.125	1.250	0.563	1.34	1.55	2.68	2.88	1.900	0.250	71,000	7.09
	mm	50.80	28.58	31.75	14.29	34.0	39.3	68.0	73.3	48.26	6.35	32,275	10.6
180HE	inch	2.250	1.406	1.406	0.687	1.52	1.74	3.04	3.26	2.137	0.281	97,000	9.19
	mm	57.15	35.71	35.71	17.46	38.6	44.1	77.3	82.8	54.29	7.14	44,090	13.7
200HE	inch	2.500	1.562	1.500	0.781	1.72	1.93	3.43	3.65	2.375	0.312	115,000	12.8
	mm	63.50	39.67	38.10	19.85	43.6	49.1	87.1	92.7	60.32	7.92	52,275	19.1

ASME/ANSI Heavy-Through Hardened Pin (HE) Roller Chain

Chain Dimensions - Double Strand

MAXCO Chain Number	Units	Chain Pitch P	Roller			Pin				Side Plate		Trans. Pitch TP	Average Ultimate Strength Lbs Kg-f	Average Chain Weight Lbs/ft Kg/m
			Dia	Inside Width	Dia	Length				Height	Thick.			
			R	W	D	L1	L2	LR	LC	H	T			
60HE-2	inch	0.750	0.469	0.500	0.235	1.08	1.17	2.17	2.26	0.712	0.125	1.028	24,300	2.30
	mm	19.05	11.91	12.70	5.96	27.6	29.8	55.1	57.3	18.09	3.18	26.11	11,045	3.43
80HE-2	inch	1.000	0.625	0.625	0.313	1.37	1.52	2.74	2.89	0.950	0.156	1.283	43,600	3.96
	mm	25.40	15.88	15.88	7.94	34.8	38.7	69.5	73.4	24.13	3.96	32.59	19,820	5.91
100HE-2	inch	1.250	0.750	0.750	0.376	1.64	1.76	3.27	3.40	1.187	0.187	1.539	62,000	5.87
	mm	31.75	19.05	19.05	9.54	41.6	44.8	83.2	86.4	30.2	4.75	39.09	28,180	8.75
120HE-2	inch	1.500	0.875	1.000	0.437	2.05	2.23	4.10	4.28	1.425	0.219	1.924	84,000	8.38
	mm	38.10	22.23	25.40	11.11	52.0	56.7	104.1	108.8	36.2	5.56	48.87	38,180	12.5
140HE-2	inch	1.750	1.000	1.000	0.500	2.17	2.37	4.34	4.54	1.662	0.250	2.055	110,000	10.9
	mm	44.45	25.40	25.40	12.71	55.2	60.2	110.3	115.3	42.2	6.35	52.20	50,000	16.2
160HE-2	inch	2.000	1.125	1.250	0.563	2.56	2.76	5.11	5.32	1.900	0.281	2.437	142,000	14.1
	mm	50.80	28.58	31.75	14.29	65.0	70.2	129.9	135.2	48.26	7.14	61.90	64,545	21.1
180HE-2	inch	2.250	1.406	1.406	0.687	2.88	3.35	5.76	6.23	2.137	0.312	2.723	194,000	18.2
	mm	57.15	35.71	35.71	17.46	73.2	85.0	146.4	158.2	54.29	7.92	69.16	88,180	27.1
200HE-2	inch	2.500	1.562	1.500	0.781	3.26	3.48	6.51	6.73	2.375	0.375	3.083	230,000	25.4
	mm	63.50	39.67	38.10	19.85	82.7	88.3	165.4	171.0	60.32	9.53	78.31	104,545	37.9

Chain Dimensions - Triple Strand

MAXCO Chain Number	Units	Chain Pitch P	Roller			Pin				Side Plate		Trans. Pitch TP	Average Ultimate Strength Lbs Kg-f	Average Chain Weight Lbs/ft Kg/m
			Dia	Inside Width	Dia	Length				Height	Thick.			
			R	W	D	L1	L2	LR	LC	H	T			
60HE-3	inch	0.750	0.469	0.500	0.235	1.60	1.69	3.20	3.28	0.712	0.125	1.028	36,450	3.43
	mm	19.05	11.91	12.70	5.96	40.6	42.8	81.2	83.4	18.09	3.18	26.11	16,570	5.11
80HE-3	inch	1.000	0.625	0.625	0.313	2.01	2.16	4.02	4.17	0.950	0.156	1.283	65,400	5.89
	mm	25.40	15.88	15.88	7.94	51.0	54.9	102.1	106.0	24.13	3.96	32.59	29,725	8.78
100HE-3	inch	1.250	0.750	0.750	0.376	2.41	2.53	4.81	4.94	1.187	0.187	1.539	93,000	8.72
	mm	31.75	19.05	19.05	9.54	61.1	64.3	122.3	125.4	30.2	4.75	39.09	42,275	13.0
120HE-3	inch	1.500	0.875	1.000	0.437	3.01	3.20	6.02	6.21	1.425	0.219	1.924	126,000	12.6
	mm	38.10	22.23	25.40	11.11	76.5	81.2	152.9	157.6	36.2	5.56	48.87	57,275	18.7
140HE-3	inch	1.750	1.000	1.000	0.500	3.20	3.40	6.40	6.60	1.662	0.250	2.055	165,000	16.3
	mm	44.45	25.40	25.40	12.71	81.3	86.3	162.5	167.5	42.2	6.35	52.20	75,000	24.3
160HE-3	inch	2.000	1.125	1.250	0.563	3.78	3.98	7.55	7.76	1.900	0.281	2.437	213,000	21.1
	mm	50.80	28.58	31.75	14.29	95.9	101.2	191.8	197.1	48.26	7.14	61.90	96,820	31.4
180HE-3	inch	2.250	1.406	1.406	0.687	4.24	4.71	8.49	8.95	2.137	0.312	2.723	291,000	27.2
	mm	57.15	35.71	35.71	17.46	107.8	119.6	215.6	227.4	54.29	7.92	69.16	132,275	40.5
200HE-3	inch	2.500	1.562	1.500	0.781	4.80	5.02	9.60	9.82	2.375	0.375	3.083	345,000	38.0
	mm	63.50	39.67	38.10	19.85	121.9	127.4	243.8	249.3	60.32	9.53	78.31	156,820	56.7

ASME/ANSI Transmission Series Double Pitch Roller Chain

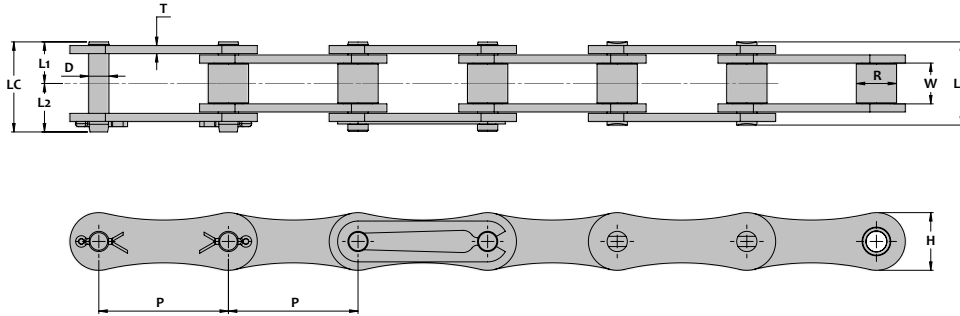

Chain Dimensions

MAXCO Chain Number	Units	Chain Pitch P	Roller		Dia D	Pin				Side Plate		Average Ultimate Strength Lbs Kg-f	Rated Working Load Lbs Kg-f	Average Chain Weight Lbs/ft Kg/m
			Dia. R	Inside Width W		Length	Height H	Thick. T						
			L1	L2					LR	LC				
A2040	inch	1.000	0.312	0.313	0.157	0.32	0.41	0.65	0.73	0.475	0.060	3,800	660	0.27
	mm	25.40	7.92	7.95	3.98	8.2	10.3	16.4	18.5	12.06	1.5	1,725	300	0.41
A2050	inch	1.250	0.400	0.375	0.200	0.40	0.49	0.80	0.89	0.594	0.080	6,100	990	0.46
	mm	31.75	10.16	9.53	5.08	10.2	12.4	20.3	22.6	15.08	2.0	2,775	450	0.68
A2060	inch	1.500	0.469	0.500	0.234	0.50	0.60	1.00	1.10	0.712	0.094	9,000	1,430	0.64
	mm	38.10	11.91	12.70	5.96	12.7	15.3	25.4	28.0	18.09	2.4	4,090	650	0.95
A2080	inch	2.000	0.625	0.625	0.312	0.65	0.80	1.30	1.45	0.950	0.126	15,200	2,430	1.17
	mm	50.80	15.88	15.88	7.94	16.5	20.4	33.0	36.9	24.13	3.2	6,910	1,105	1.75

ISO British Standard Double Pitch Roller Chain

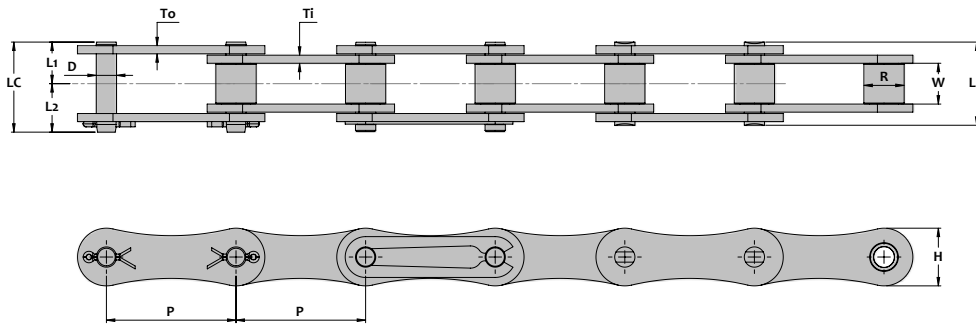

Chain Dimensions

MAXCO Chain Number	Units	Chain Pitch P	Roller		Dia D	Pin				Side Plate		Average Ultimate Strength Lbs Kg-f	Average Chain Weight Lbs/ft Kg/m	
			Dia. R	Inside Width W		Length	Height H	Thickness						
			L1	L2				LR	LC	To	Ti			
A208B	inch	1.000	0.335	0.305	0.175	0.32	0.41	0.65	0.73	0.465	0.059	0.062	4,230	0.30
	mm	25.40	8.51	7.75	4.45	8.2	10.3	16.4	18.5	11.81	1.49	1.58	1,925	0.44
A210B	inch	1.250	0.400	0.380	0.200	0.39	0.48	0.78	0.87	0.580	0.067		6,000	0.44
	mm	31.75	10.16	9.65	5.08	9.9	12.3	19.7	22.1	14.73	1.71		2,725	0.66
A212B	inch	1.500	0.475	0.460	0.225	0.44	0.57	0.89	1.02	0.635	0.073		7,230	0.52
	mm	38.10	12.07	11.68	5.72	11.3	14.6	22.5	25.8	16.13	1.86		3,285	0.78
A216B	inch	2.000	0.625	0.670	0.326	0.71	0.83	1.43	1.54	0.830	0.125	0.157	17,110	1.12
	mm	50.80	15.88	17.02	8.28	18.1	21.1	36.2	39.2	21.08	3.18	3.99	7,775	1.67

ASME/ANSI Conveyor Series Double Pitch Roller Chain

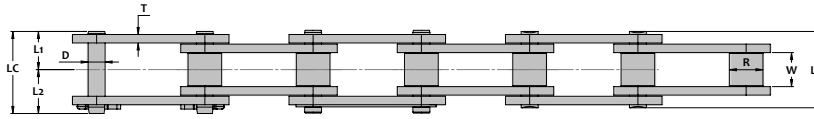

Standard Roller

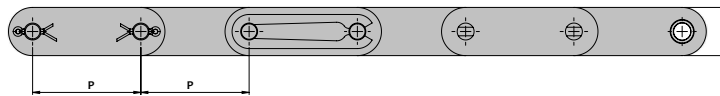

Large Roller

Chain Dimensions - Standard Roller

MAXCO Chain Number	Units	Chain Pitch P	Roller		Pin					Side Plate		Average Ultimate Strength Lbs Kg-f	Rated Working Load Lbs Kg-f	Average Chain Weight Lbs/ft Kg/m
			Dia	Inside Width	Dia	Length			Height	Thick.				
			R	W	D	L1	L2	LR	LC	H	T			
C2040	inch	1.000	0.312	0.313	0.156	0.32	0.41	0.65	0.73	0.440	0.060	3,800	660	0.32
	mm	25.40	7.92	7.95	3.96	8.2	10.3	16.4	18.5	11.17	1.5	1,727	300	0.47
C2050	inch	1.250	0.400	0.375	0.200	0.40	0.49	0.80	0.89	0.545	0.080	6,100	990	0.54
	mm	31.75	10.16	9.53	5.08	10.2	12.4	20.3	22.6	13.84	2.0	2,775	450	0.80
C2060H	inch	1.500	0.469	0.500	0.234	0.57	0.67	1.13	1.23	0.712	0.126	9,000	1,540	0.95
	mm	38.10	11.91	12.70	5.95	14.4	16.9	28.8	31.3	18.09	3.2	4,090	700	1.41
C2080H	inch	2.000	0.625	0.625	0.312	0.71	0.89	1.43	1.60	0.950	0.157	15,200	2,650	1.60
	mm	50.80	15.88	15.88	7.93	18.2	22.6	36.3	40.7	24.13	4.0	6,910	1,205	2.38
C2100H	inch	2.500	0.750	0.750	0.375	0.86	1.00	1.72	1.86	1.187	0.189	24,300	4,080	2.45
	mm	63.50	19.05	19.05	9.53	21.8	25.3	43.7	47.2	30.16	4.8	11,045	1,855	3.66
C2120H	inch	3.000	0.875	1.000	0.437	1.07	1.26	2.14	2.34	1.369	0.220	34,000	5,510	3.47
	mm	76.20	22.23	25.40	11.10	27.2	32.1	54.5	59.4	34.77	5.6	15,455	2,505	5.18
C2160H	inch	4.000	1.125	1.250	0.562	1.34	1.55	2.68	2.88	1.900	0.283	58,000	9,260	5.73
	mm	101.60	28.58	31.75	14.28	34.0	39.3	68.0	73.3	48.26	7.2	26,365	4,210	8.55

Chain Dimensions - Large Roller

C2042	inch	1.000	0.625	0.313	0.156	0.32	0.41	0.65	0.73	0.440	0.060	3,800	660	0.56
	mm	25.40	15.88	7.95	3.96	8.2	10.3	16.4	18.5	11.17	1.5	1,727	300	0.83
C2052	inch	1.250	0.750	0.375	0.200	0.40	0.49	0.80	0.89	0.545	0.080	6,100	990	0.85
	mm	31.75	19.05	9.53	5.08	10.2	12.4	20.3	22.6	13.84	2.0	2,775	450	1.27
C2062H	inch	1.500	0.875	0.500	0.234	0.57	0.67	1.13	1.23	0.712	0.126	9,000	1,540	1.43
	mm	38.10	22.23	12.70	5.95	14.4	16.9	28.8	31.3	18.09	3.2	4,090	700	2.13
C2082H	inch	2.000	1.125	0.625	0.312	0.71	0.89	1.43	1.60	0.950	0.157	15,200	2,650	2.31
	mm	50.80	28.58	15.88	7.93	18.2	22.6	36.3	40.7	24.13	4.0	6,910	1,205	3.45
C2102H	inch	2.500	1.562	0.750	0.375	0.86	1.00	1.72	1.86	1.187	0.189	24,300	4,080	3.94
	mm	63.50	39.67	19.05	9.53	21.8	25.3	43.7	47.2	30.16	4.8	11,045	1,855	5.87
C2122H	inch	3.000	1.750	1.000	0.437	1.07	1.26	2.14	2.34	1.369	0.220	34,000	5,510	5.42
	mm	76.20	44.45	25.40	11.10	27.2	32.1	54.5	59.4	34.77	5.6	15,455	2,505	8.09
C2162H	inch	4.000	2.250	1.250	0.562	1.34	1.55	2.68	2.88	1.900	0.283	58,000	9,260	8.71
	mm	101.60	57.15	31.75	14.28	34.0	39.3	68.0	73.3	48.26	7.2	26,365	4,210	13.0

ASME/ANSI Straight (Flat) Side Bar Roller Chain

ASME/ANSI Straight (Flat) Side Bar roller chains are identical to ASME/ANSI standard chains except that the side bar is straight rather than contoured. These chains are most often used for light to moderate duty material handling conveyors where the side bars are allowed to slide on a conveyor track. The straight side bar design also allows unit materials to sit on top of the chains easily in conveyor applications.

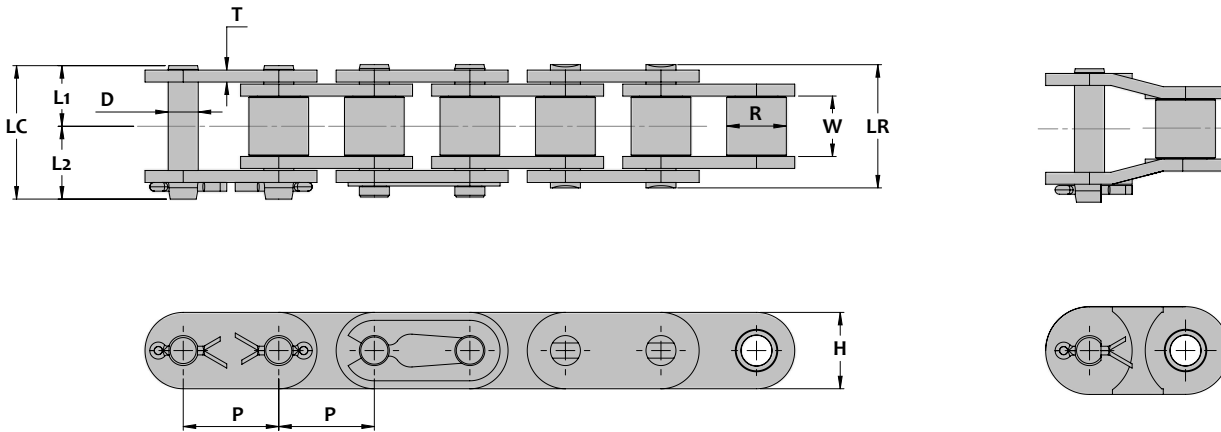

Chain Dimensions

MAXCO Chain Number	Units	Chain Pitch P	Roller		Dia D	Pin				Side Plate		Average Ultimate Strength Lbs Kg-f	Average Chain Weight Lbs/ft Kg/m
			Dia R	Inside Width W		Length	Height H	Thick. T					
									L1	L2	LR		
25F	inch	0.250	0.130	0.125	0.091	0.15	0.19	0.31	0.34	0.228	0.030	1,010	0.08
	mm	6.35	3.30	3.18	2.31	3.9	4.7	7.8	8.6	5.80	0.76	459	0.12
40F	inch	0.500	0.312	0.313	0.156	0.32	0.41	0.65	0.73	0.463	0.060	4,190	0.46
	mm	12.70	7.92	7.95	3.96	8.2	10.3	16.4	18.5	11.75	1.52	1,905	0.69
50F	inch	0.625	0.400	0.375	0.200	0.40	0.49	0.80	0.89	0.580	0.080	6,830	0.72
	mm	15.88	10.16	9.52	5.09	10.2	12.4	20.3	22.6	14.73	2.03	3,105	1.08
60F	inch	0.750	0.469	0.500	0.235	0.50	0.60	1.00	1.10	0.685	0.125	9,260	1.04
	mm	19.05	11.91	12.70	5.96	12.7	15.3	25.4	28.0	17.40	2.39	4,210	1.55
80F	inch	1.000	0.625	0.625	0.313	0.65	0.80	1.30	1.45	0.950	0.125	17,600	1.94
	mm	25.40	15.88	15.88	7.94	16.5	20.4	33.0	36.9	24.13	3.18	8,000	2.90
100F	inch	1.250	0.750	0.750	0.376	0.78	0.95	1.56	1.73	1.187	0.156	25,350	3.03
	mm	31.75	19.05	19.05	9.54	19.8	24.1	39.7	44.0	30.16	3.96	11,525	4.52
120F	inch	1.500	0.875	1.000	0.437	1.01	1.17	2.01	2.18	1.425	0.187	34,390	4.04
	mm	38.10	22.23	25.40	11.11	25.5	29.8	51.1	55.4	36.19	4.75	15,630	6.02
140F	inch	1.750	1.000	1.000	0.500	1.07	1.27	2.15	2.34	1.662	0.219	46,300	5.86
	mm	44.45	25.40	25.40	12.71	27.3	32.2	54.5	59.4	42.22	5.56	21,045	8.74
160F	inch	2.000	1.125	1.250	0.563	1.29	1.46	2.58	2.75	1.900	0.250	57,760	7.26
	mm	50.80	28.58	31.75	14.29	32.8	37.1	65.5	69.8	48.26	6.35	26,255	10.8

ISO 606B British Standard Straight (Flat) Side Bar Roller Chain

ISO 606B British Standard Straight (Flat) Side Bar roller chains are identical to ISO 606B British Standard chains except that the side bar is straight rather than contoured. These chains are most often used for light to moderate duty material handling conveyors where the side bars are allowed to slide on a conveyor track. The straight side bar design also allows unit materials to sit on top of the chains easily in conveyor applications.

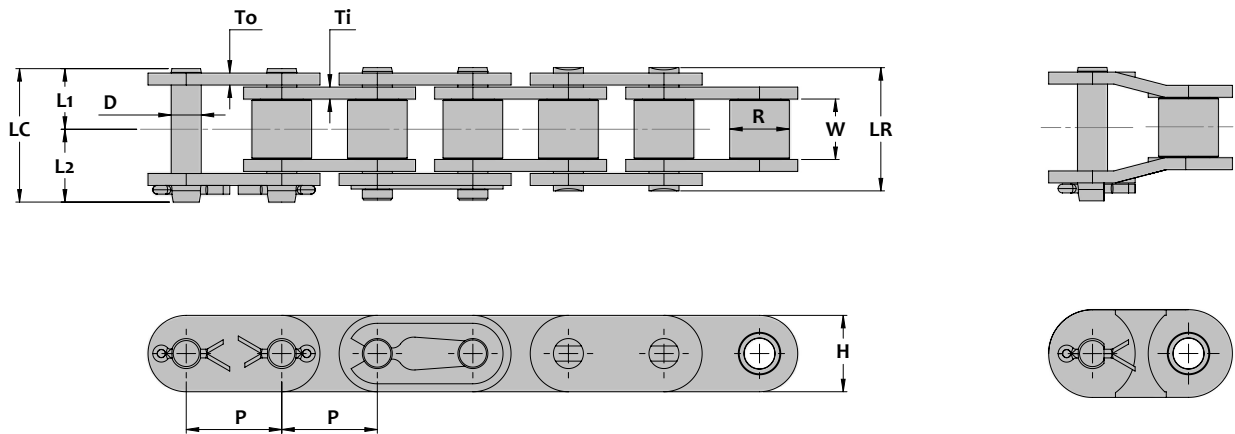

Chain Dimensions

MAXCO Chain Number	Units	Chain Pitch P	Roller		Pin					Side Plate		Average Ultimate Strength Lbs Kg-f	Average Chain Weight Lbs/ft Kg/m	
			Inside Width W	Dia R	Dia D	Length				Height H	Thickness			
						L1	L2	LR	LC	To	Ti			
08BF	inch	0.500	0.305	0.335	0.175	0.32	0.41	0.65	0.73	0.463	0.060		4,230	0.50
	mm	12.70	8.51	8.51	4.45	8.2	10.3	16.5	18.6	11.75	1.50		1,925	0.75
10BF	inch	0.625	0.400	0.380	0.200	0.39	0.48	0.78	0.87	0.580	0.067		5,500	0.66
	mm	15.88	10.16	9.65	5.08	9.9	12.3	19.7	22.1	14.73	1.71		2,500	0.98
12BF	inch	0.750	0.475	0.460	0.225	0.44	0.57	0.89	1.02	0.635	0.073		7,100	0.86
	mm	19.05	12.07	11.68	5.72	11.3	14.6	22.5	25.8	16.13	1.86		3,225	1.28
16BF	inch	1.000	0.625	0.670	0.326	0.71	0.83	1.43	1.54	0.830	0.125	0.157	15,000	1.94
	mm	25.40	15.88	17.02	8.28	18.1	21.1	36.2	39.2	21.08	3.18	3.99	6,820	2.89
20BF	inch	1.250	0.750	0.770	0.400	0.79	0.96	1.58	1.75	1.040	0.125	0.176	23,150	2.58
	mm	31.75	19.05	19.56	10.19	20.1	24.4	40.2	44.5	26.42	3.18	4.46	10,525	3.85
24BF	inch	1.500	1.000	1.000	0.576	1.07	1.27	2.13	2.33	1.315	0.189	0.236	39,680	4.92
	mm	38.10	25.40	25.40	14.63	27.1	32.2	54.1	59.2	33.40	4.80	6.00	18,035	7.33
28BF	inch	1.750	1.100	1.220	0.626	1.30	1.47	2.59	2.77	1.460	0.236	0.287	50,000	6.57
	mm	44.45	27.94	30.99	15.90	33.0	37.5	65.9	70.4	37.08	6.00	7.30	22,725	9.80
32BF	inch	2.000	1.150	1.220	0.701	1.31	1.50	2.61	2.81	1.665	0.236	0.276	61,000	6.82
	mm	50.80	29.21	30.99	17.81	33.2	38.2	66.3	71.3	42.29	6.00	7.00	27,725	10.2

ASME/ANSI Standard Roller Chain

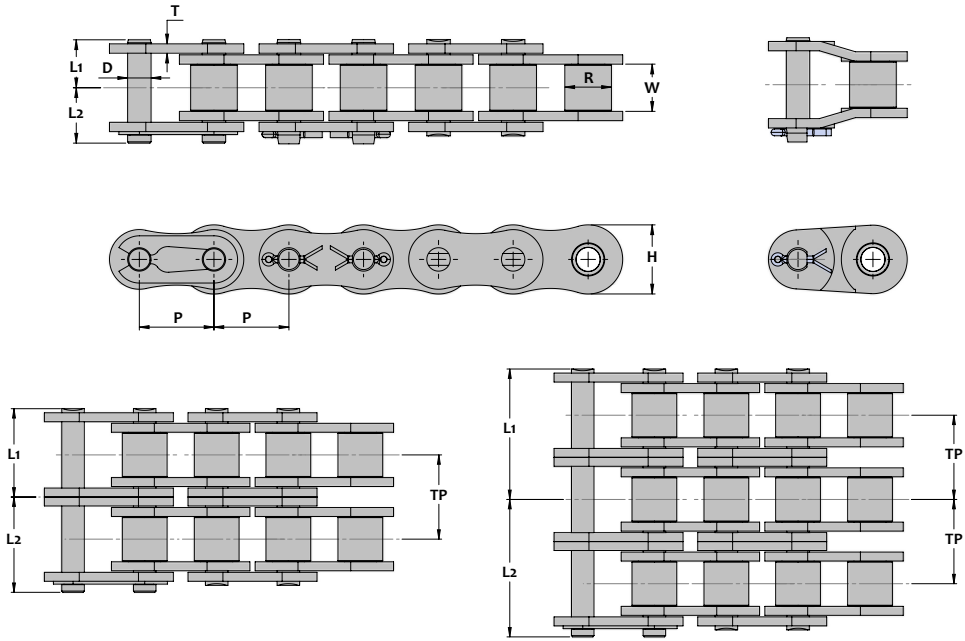

Chain Dimensions

MAXCO Chain Number	Units	Chain Pitch P	Roller		Pin		Side Plate		Trans. Pitch TP	Average Ultimate Strength Lbs Kg-f	Rated Working Load Lbs Kg-f	Number of Links 10ft 5m	Average Chain Weight Lbs/ft Kg/m	
			Inside Width W	Dia R	Dia D	Length		Height H						Thick. T
						L1	L2							
25	inch	0.250	0.125	0.130	0.091	0.18	0.28	0.237	0.030	-	880	140	480	0.09
	mm	6.35	3.18	3.30	2.31	4.6	7.1	6.02	0.75	-	400	64	788	0.14
35	inch	0.375	0.188	0.200	0.142	0.26	0.39	0.356	0.049	-	2,320	475	320	0.22
	mm	9.525	4.78	5.08	3.60	6.6	9.9	9.05	1.25	-	1,055	216	526	0.33
35-2	inch					0.46	0.59			0.398	4,520	800		0.46
	mm					11.7	15.0			10.10	2,055	364		0.69
35-3	inch					0.66	0.79			0.398	6,830	1,175		0.70
	mm					16.8	20.1			10.10	3,105	534		1.05
41	inch	0.500	0.246	0.306	0.142	0.28	0.35	0.390	0.049	-	2,600	500	240	0.27
	mm	12.70	6.25	7.77	3.60	7.0	9.0	9.91	1.25	-	1,180	227	394	0.41
40	inch	0.500	0.312	0.312	0.157	0.35	0.50	0.475	0.059	-	4,080	800	240	0.42
	mm	12.70	7.92	7.92	3.98	8.9	12.8	12.07	1.50	-	1,855	364	394	0.63
40-2	inch					0.64	0.79			0.567	7,940	1,375		0.80
	mm					16.2	20.1			14.40	3,610	625		1.19
40-3	inch					0.92	1.07			0.567	11,900	2,000		1.19
	mm					23.4	27.3			14.40	5,410	909		1.77
50	inch	0.625	0.375	0.400	0.200	0.43	0.59	0.594	0.079	-	6,830	1,350	192	0.68
	mm	15.875	9.53	10.16	5.09	10.9	15.0	15.09	2.00	-	3,105	614	316	1.01
50-2	inch					0.79	0.95			0.713	13,670	2,380		1.37
	mm					20.0	24.1			18.10	6,215	1,080		2.04
50-3	inch					1.14	1.30			0.713	20,500	3,500		2.05
	mm					29.0	33.1			18.10	9,320	1,590		3.05
60	inch	0.750	0.500	0.469	0.235	0.53	0.71	0.713	0.094	-	9,250	2,000	160	0.97
	mm	19.05	12.70	11.91	5.96	13.5	18.1	18.10	2.40	-	4,205	909	262	1.44
60-2	inch					0.98	1.16			0.898	18,500	3,300		2.03
	mm					24.9	29.5			22.8	8,410	1,500		3.03
60-3	inch					1.43	1.61			0.898	27,500	4,900		3.02
	mm					36.3	40.9			22.8	12,500	2,225		4.50

ASME/ANSI Standard Roller Chain

Chain Dimensions

MAXCO Chain Number	Units	Chain Pitch P	Roller		Pin			Side Plate		Trans. Pitch TP	Average Ultimate Strength Lbs Kg-f	Rated Working Load Lbs Kg-f	Number of Links 10ft 5m	Average Chain Weight Lbs/ft Kg/m
			Inside Width W	Dia R	Dia D	Length		Height H	Thick. T					
						L1	L2							
80	inch	1.000	0.625	0.625	0.313	0.66	0.87	0.950	0.126	-	17,500	3,200	120	1.61
	mm	25.40	15.88	15.88	7.94	16.8	22.2	24.13	3.20	-	7,955	1,515	198	2.40
80-2	inch					1.23	1.45			1.154	35,000	5,500		3.53
	mm					31.4	36.8			29.30	15,910	2,500		5.26
80-3	inch					1.81	2.02			1.154	52,500	8,200		5.23
	mm					46.0	51.4			29.30	23,865	3,725		7.80
100	inch	1.250	0.750	0.750	0.376	0.81	1.05	1.188	0.157	1.409	23,000	5,000	96	2.51
	mm	31.75	19.05	19.05	9.54	20.6	26.7	30.17	4.00	35.80	10,455	2,275	158	3.74
100-2	inch					1.52	1.76				46,000	8,500		5.04
	mm					38.5	44.6				20,910	3,865		7.51
100-3	inch					2.22	2.46				69,000	12,500		7.51
	mm					56.5	62.6				31,365	5,680		11.2
120	inch	1.500	1.000	0.875	0.437	1.00	1.26	1.425	0.189	-	34,000	6,600	80	4.14
	mm	38.10	25.40	22.23	11.11	25.4	32.0	36.20	4.80	-	15,455	3,000	132	6.18
120-2	inch					1.90	2.16			1.409	68,000	11,500		8.21
	mm					48.2	54.8			35.80	30,910	5,225		12.3
120-3	inch					2.79	3.05			1.409	102,000	17,000		12.3
	mm					70.9	77.5			35.80	46,365	7,725		18.3
140	inch	1.750	1.000	1.000	0.500	1.08	1.37	1.663	0.220	-	46,000	8,900	70	5.02
	mm	44.45	25.40	25.40	12.70	27.5	34.9	42.23	5.60	-	20,910	4,045	116	7.49
140-2	inch					2.04	2.33			1.925	92,000	15,000		9.94
	mm					51.8	59.2			48.90	41,820	6,820		14.8
140-3	inch					3.00	3.29			1.925	138,000	22,000		14.9
	mm					76.2	83.6			48.90	62,725	10,000		22.2
160	inch	2.000	1.250	1.125	0.563	1.29	1.60	1.900	0.252	-	57,000	11,500	60	6.77
	mm	50.8	31.75	28.58	14.29	32.8	40.7	48.26	6.40	-	25,910	5,225	98	10.1
160-2	inch					2.44	2.76			2.303	114,000	20,000		13.4
	mm					62.1	70.0			58.50	51,820	9,090		20.0
160-3	inch					3.60	3.91			2.303	171,000	28,000		20.1
	mm					91.5	99.4			58.50	77,725	12,725		30.0
180	inch	2.250	1.406	1.406	0.687	1.45	1.81	2.138	0.280	-	75,850	13,300	54	8.99
	mm	57.15	35.71	35.71	17.46	37.0	46.1	54.30	7.10	-	34,475	6,045	90	13.4
180-2	inch					2.76	3.11			2.592	151,720	22,000		17.6
	mm					70.0	79.1			65.84	68,965	10,000		26.2
180-3	inch					4.06	4.41			2.592	227,570	34,000		25.6
	mm					103.0	112.1			65.84	103,440	15,455		38.1
200	inch	2.500	1.500	1.562	0.781	1.58	1.98	2.375	0.315	-	93,670	15,800	48	11.1
	mm	63.50	38.1	39.68	19.85	40.2	50.4	60.33	8.00	-	42,575	7,180	80	16.5
200-2	inch					2.99	3.39			2.819	107,340	27,000		21.9
	mm					76.0	86.2			71.60	48,790	12,275		32.7
200-3	inch					4.40	4.80			2.819	281,020	40,000		32.9
	mm					111.8	122.0			71.60	127,735	18,180		49.1
240	inch	3.000	1.875	1.875	0.937	1.88	2.29	2.850	0.374	-	134,980	22,400	40	16.2
	mm	76.20	47.63	47.63	23.81	47.8	58.3	72.40	9.5	-	61,355	10,180	66	24.2
240-2	inch					3.61	4.020			3.457	269,950	37,000		32.1
	mm					91.7	102.2			87.80	122,705	16,820		47.8
240-3	inch					5.34	5.75			3.457	404,930	54,500		47.7
	mm					135.7	146.2			87.80	184,060	24,775		71.1

ISO 606B British Standard Roller Chain

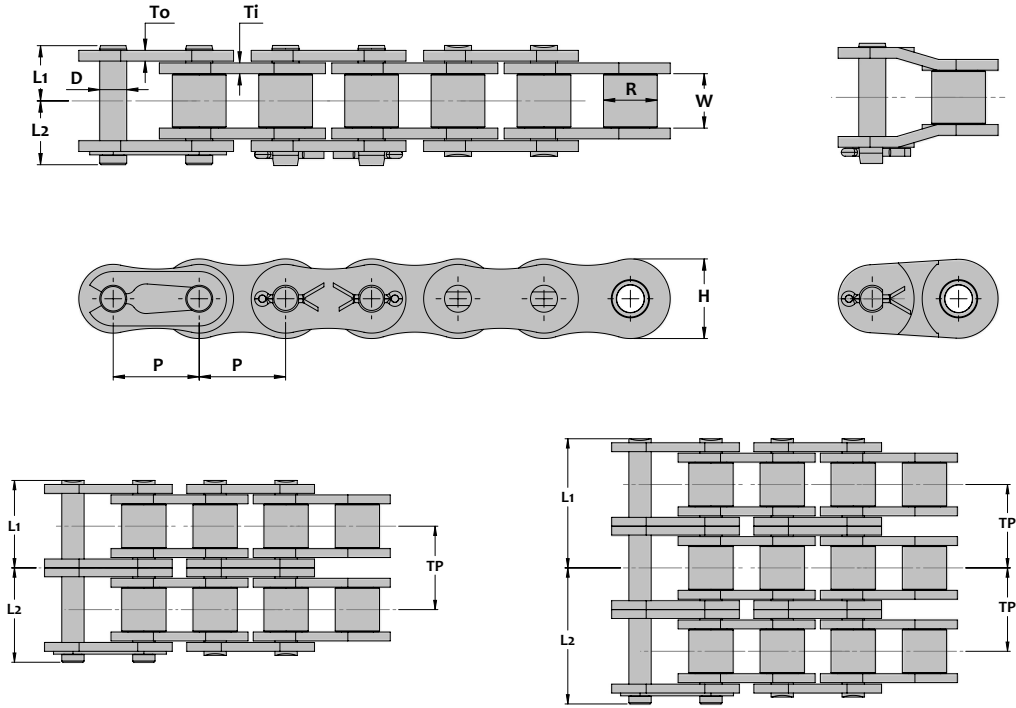

Chain Dimensions

MAXCO Chain Number	Units	Chain Pitch P	Roller		Pin		Side Plate			Trans. Pitch TP	Average Ultimate Strength Lbs Kg-f	Rated Working Load Lbs Kg-f	Number of Links 10ft 5m	Average Chain Weight Lbs/ft Kg/m	
			Inside Width W	Dia R	Dia D	Length L1	L2	Height H	Thickness						
								To	Ti						
05B	inch	0.315	0.118	0.197	0.091	0.17	0.29	.280	0.030		-	1,250	245	382	0.11
	mm	8.0	3.00	5.00	2.31	4.3	7.4	7.11	0.75		-	568	111	626	0.16
06B	inch	0.375	0.225	0.250	0.129	0.27	0.40	0.325	0.039	0.051	-	2,100	400	320	0.26
	mm	9.53	5.72	6.35	3.28	6.8	10.1	8.26	1.00	1.30	-	955	182	526	0.39
06B-2	inch					0.47	0.60				0.403	4,190	660		0.50
	mm					11.9	15.2				10.24	1,905	300		0.74
06B-3	inch					0.67	0.80				0.403	5,950	950		0.73
	mm					17.0	20.3				10.24	2,705	432		1.09
08B	inch	0.500	0.335	0.305	0.175	0.33	0.49	0.465	0.059		-	4,080	710	240	0.62
	mm	12.7	8.51	7.75	4.45	8.5	12.4	11.81	1.50		-	1,855	323	394	0.92
08B-2	inch					0.61	0.76				0.548	7,600	1,210		1.13
	mm					15.5	19.4				13.92	3,455	550		1.68
08B-3	inch					0.88	1.04				0.548	9,920	1,770		1.76
	mm					22.5	26.4				13.92	4,510	805		2.62
10B	inch	0.625	0.400	0.380	0.200	0.39	0.55	0.580	0.065		-	5,500	1,030	192	0.83
	mm	15.88	10.16	9.65	5.08	9.8	13.9	14.73	1.65		-	2,500	468	316	1.24
10B-2	inch					0.71	0.87				0.653	11,000	1,750		1.53
	mm					18.1	22.2				16.59	5,000	795		2.28
10B-3	inch					1.04	1.20				0.653	16,000	2,580		2.38
	mm					26.4	30.5				16.59	7,275	1,175		3.55

ISO 606B British Standard Roller Chain

Chain Dimensions

MAXCO Chain Number	Units	Chain Pitch P	Roller			Pin		Side Plate			Trans. Pitch TP	Average Ultimate Strength Lbs Kg-f	Rated Working Load Lbs Kg-f	Number of Links 10ft 5m	Average Chain Weight Lbs/ft Kg/m
			Inside Width W	Dia R	Dia D	Length L1 L2		Height H	Thickness To Ti						
12B	inch	0.750	0.475	0.460	0.225	0.45	0.63	0.635	0.067	0.071	-	7,100	1,210	160	0.83
	mm	19.05	12.07	11.68	5.72	11.4	16.0	16.13	1.70	1.80	-	3,225	550	262	1.24
12B-2	inch					0.83	1.01				0.766	14,200	2,060		1.53
	mm					21.1	25.7				19.46	6,455	936		2.28
12B-3	inch					1.21	1.40				0.766	21,300	3,030		2.38
	mm					30.9	35.5				19.46	9,680	1,375		3.55
16B	inch	1.000	0.625	0.670	0.326	0.71	0.92	0.830	0.126	0.157	-	15,000	3,010	120	1.78
	mm	25.4	15.88	17.02	8.28	18.1	23.5	21.08	3.20	4.00	-	6,820	1,370	198	2.65
16B-2	inch					1.34	1.55				1.255	30,000	4,800		3.52
	mm					34.0	39.4				31.88	16,635	2,180		5.25
16B-3	inch					1.97	2.18				1.255	45,000	7,000		5.27
	mm					50.0	55.4				31.88	20,455	3,180		7.86
20B	inch	1.250	0.750	0.770	0.401	0.85	1.09	1.040	0.138	0.177	-	23,000	4,190	96	2.58
	mm	31.75	19.05	19.56	10.19	21.6	27.7	26.42	3.50	4.50	-	10,455	1,905	158	3.85
20B-2	inch					1.57	1.81				1.435	43,870	7,160		5.13
	mm					39.9	46.0				36.45	19,940	3,255		7.65
20B-3	inch					2.29	2.53				1.435	64,600	10,470		7.68
	mm					58.1	64.2				36.45	29,365	4,760		11.5
24B	inch	1.500	1.000	1.000	0.576	1.05	1.31	1.315	0.205	0.236	-	36,500	6,200	80	5.10
	mm	38.1	25.4	25.4	14.63	26.7	33.3	33.40	5.20	6.00	-	16,590	2,820	132	7.60
24B-2	inch					2.00	2.26				1.904	78,600	10,520		9.92
	mm					50.9	57.5				48.36	35,725	4,780		14.8
24B-3	inch					2.96	3.22				1.904	115,960	15,470		14.7
	mm					75.1	81.7				48.36	52,710	7,030		21.9
28B	inch	1.750	1.100	1.220	0.626	1.28	1.57	1.460	0.248	0.295	-	50,000	8,570	70	6.07
	mm	44.45	27.94	30.99	15.90	32.6	40.0	37.08	6.30	7.50	-	22,725	3,895	116	9.05
28B-2	inch					2.45	2.75				2.345	94,000	13,100		11.5
	mm					62.4	69.8				59.56	42,725	5,955		17.1
28B-3	inch					3.63	3.92				2.345	139,000	19,290		17.2
	mm					92.2	99.6				59.56	63,180	8,770		25.6
32B	inch	2.000	1.150	1.220	0.701	1.33	1.64	1.665	0.248	0.280	-	61,000	9,380	60	7.13
	mm	50.8	29.21	30.99	17.81	33.7	41.6	42.29	6.30	7.10	-	27,725	4,265	98	10.6
32B-2	inch					2.48	2.79				2.305	121,500	14,970		14.0
	mm					63.0	70.9				58.55	55,225	6,805		20.9
32B-3	inch					3.63	3.94				2.305	181,000	22,030		21.2
	mm					92.3	100.2				58.55	82,275	10,015		31.6
40B	inch	2.500	1.550	1.500	0.901	1.63	2.03	2.085	0.315	0.335	-	93,000	11,700	48	10.9
	mm	63.5	39.37	38.1	22.89	41.3	51.5	52.96	8.00	8.50	-	42,275	5,320	80	16.3
40B-2	inch					3.05	3.45				2.846	171,000	19,840		21.4
	mm					77.5	87.7				72.29	77,725	9,020		31.9
40B-3	inch					4.47	4.87				2.846	256,500	29,400		32.3
	mm					113.8	123.8				72.29	116,590	13,365		48.1
48B	inch	3.000	1.900	1.800	1.151	1.95	2.36	2.515	0.394	0.476	-	140,000	17,620	40	16.8
	mm	76.2	48.26	45.72	29.24	49.6	60.1	63.88	10.00	12.10	-	63,635	8,010	66	25.1
48B-2	inch					3.75	4.16				3.591	270,000	30,070		33.4
	mm					95.2	105.7				91.21	122,725	13,670		49.8
48B-3	inch					5.54	5.96				3.591	405,000	44,210		50.3
	mm					140.8	151.3				91.21	184,090	20,095		75.1

ASME/ANSI Heavy (H) Series Roller Chain

Heavy Series roller chains are built for power transmission applications that require additional shock load capacity or link plate strength. They are dimensionally equivalent to ASME/ANSI standard chains except that link plates are one size thicker. Single strand chains operate on standard sprockets however multiple strand chains require special sprockets due to their increased transverse pitch.

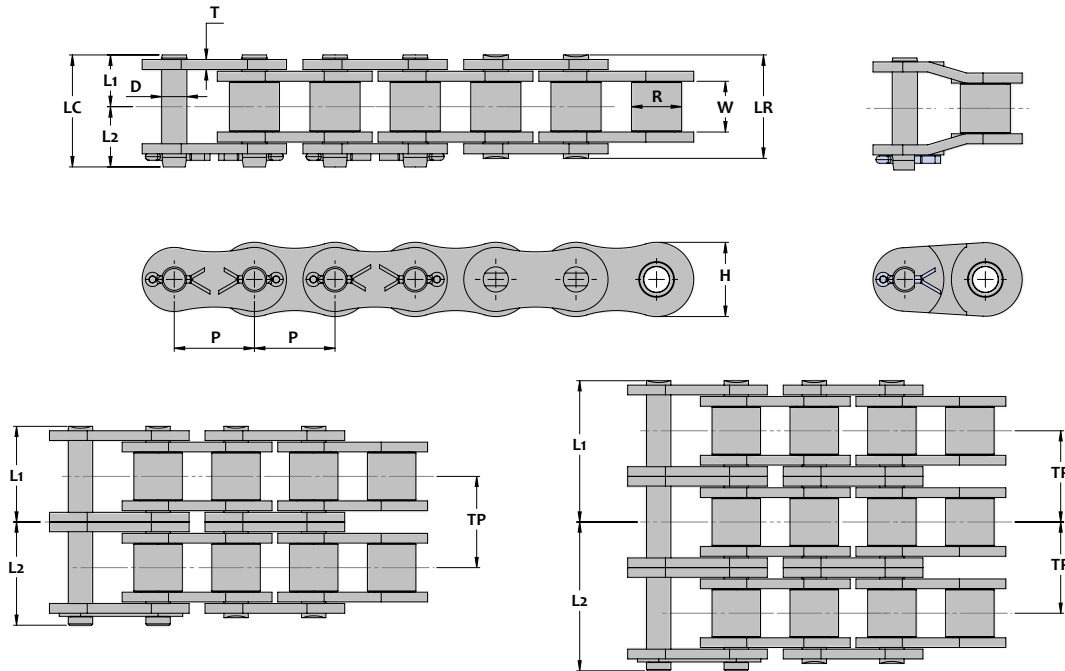

Chain Dimensions - Single Strand

MAXCO Chain Number	Units	Chain Pitch P	Roller			Pin				Side Plate		Average Ultimate Strength Lbs Kg-f	Average Chain Weight Lbs/ft Kg/m
			Dia	Inside Width	Dia	Length				Height	Thick.		
			R	W	D	L1	L2	LR	LC	H	T		
50H	inch	0.625	0.400	0.375	0.200	0.45	0.63	0.91	1.08	0.594	0.094	7,300	0.75
	mm	15.88	10.16	9.52	5.09	11.6	16.0	23.1	27.5	15.09	2.40	3,320	1.12
60H	inch	0.750	0.469	0.500	0.235	0.59	0.78	1.19	1.37	0.713	0.126	11,700	1.21
	mm	19.05	11.91	12.70	5.96	15.1	19.7	30.2	34.8	18.10	3.20	5,320	1.81
80H	inch	1.000	0.625	0.625	0.313	0.74	0.95	1.47	1.69	0.950	0.157	20,000	1.98
	mm	25.40	15.88	15.88	7.94	18.7	24.1	37.4	42.8	24.13	4.00	9,090	2.95
100H	inch	1.250	0.750	0.750	0.376	0.88	1.12	1.75	1.99	1.188	0.189	30,000	2.98
	mm	31.75	19.05	19.05	9.54	22.3	28.4	44.5	50.6	30.17	4.80	13,635	4.45
120H	inch	1.500	0.875	1.000	0.437	1.08	1.34	2.17	2.43	1.425	0.220	38,000	4.55
	mm	38.10	22.23	25.40	11.11	27.5	34.1	55.0	61.6	36.20	5.60	17,275	6.78
140H	inch	1.750	1.000	1.000	0.500	1.16	1.45	2.32	2.61	1.663	0.252	50,000	5.44
	mm	44.45	25.40	25.40	12.71	29.5	36.9	59.0	66.4	42.23	6.40	22,725	8.12
160H	inch	2.000	1.125	1.250	0.563	1.37	1.68	2.73	3.04	1.900	0.280	60,000	7.29
	mm	50.80	28.58	31.75	14.29	34.7	42.6	69.4	77.3	48.26	7.10	27,275	10.87
180H	inch	2.250	1.406	1.406	0.687	1.52	1.88	3.04	3.40	2.138	0.315	76,000	10.19
	mm	57.15	35.71	35.71	17.46	38.7	47.8	77.3	86.4	54.30	8.00	34,545	15.20
200H	inch	2.500	1.562	1.500	0.781	1.71	2.12	3.43	3.83	2.375	0.374	94,000	11.94
	mm	63.50	39.67	38.10	19.85	43.6	53.8	87.1	97.3	60.33	9.50	42,725	17.80

ASME/ANSI Heavy (H) Series Roller Chain

Chain Dimensions - Double Strand

MAXCO Chain Number	Units	Chain Pitch P	Roller			Pin				Side Plate		Trans. Pitch TP	Average Ultimate Strength Lbs Kg-f	Average Chain Weight Lbs/ft Kg/m
			Dia R	Inside Width W	Dia D	Length				Height H	Thick. T			
						L1	L2	LR	LC					
60H-2	inch	0.750	0.469	0.500	0.235	1.11	1.29	2.22	2.40	0.713	0.126	1.028	23,400	2.39
	mm	19.05	11.91	12.70	5.96	28.2	32.8	56.3	60.9	18.10	3.20	26.10	10,635	3.57
80H-2	inch	1.000	0.625	0.625	0.313	1.38	1.59	2.76	2.97	0.950	0.157	1.283	40,000	3.92
	mm	25.40	15.88	15.88	7.94	35.0	40.4	70.0	75.4	24.13	4.00	32.60	18,180	5.85
100H-2	inch	1.250	0.750	0.750	0.376	1.65	1.89	3.29	3.53	1.188	0.189	1.539	60,000	5.59
	mm	31.75	19.05	19.05	9.54	41.8	47.9	83.6	89.7	30.17	4.80	39.10	27,275	8.34
120H-2	inch	1.500	0.875	1.000	0.437	2.05	2.31	4.09	4.35	1.425	0.220	1.925	76,000	9.02
	mm	38.10	22.23	25.40	11.11	52.0	58.6	103.9	110.5	36.20	5.60	48.90	34,545	13.5
140H-2	inch	1.750	1.000	1.000	0.500	2.19	2.48	4.38	4.67	1.663	0.252	2.055	100,000	10.8
	mm	44.45	25.40	25.40	12.71	55.6	63.0	111.2	118.6	42.23	6.40	52.20	45,455	16.1
160H-2	inch	2.000	1.125	1.250	0.563	2.58	2.90	5.17	5.48	1.900	0.280	2.437	120,000	14.0
	mm	50.80	28.58	31.75	14.29	65.7	73.6	131.3	139.2	48.26	7.10	61.90	54,545	20.9
180H-2	inch	2.250	1.406	1.406	0.687	2.88	3.24	5.77	6.13	2.138	0.315	2.724	152,000	20.2
	mm	57.15	35.71	35.71	17.46	73.3	82.4	146.5	155.6	54.30	8.00	69.20	69,090	30.1
200H-2	inch	2.500	1.562	1.500	0.781	3.26	3.66	6.51	6.91	2.375	0.374	3.083	188,000	23.6
	mm	63.50	39.67	38.10	19.85	82.7	92.9	165.4	175.6	60.33	9.50	78.30	85,455	35.2

Chain Dimensions - Triple Strand

MAXCO Chain Number	Units	Chain Pitch P	Roller			Pin				Side Plate		Trans. Pitch TP	Average Ultimate Strength Lbs Kg-f	Average Chain Weight Lbs/ft Kg/m
			Dia R	Inside Width W	Dia D	Length				Height H	Thick. T			
						L1	L2	LR	LC					
60H-3	inch	0.750	0.469	0.500	0.235	1.62	1.80	3.24	3.43	0.713	0.126	1.028	35,100	3.46
	mm	19.05	11.91	12.70	5.96	41.2	45.8	82.4	87.0	18.10	3.20	26.10	15,955	5.16
80H-3	inch	1.000	0.625	0.625	0.313	2.02	2.23	4.04	4.25	0.950	0.157	1.283	60,000	5.58
	mm	25.40	15.88	15.88	7.94	51.3	56.7	102.6	108.0	24.13	4.00	32.60	27,275	8.32
100H-3	inch	1.250	0.750	0.750	0.376	2.42	2.66	4.83	5.07	1.188	0.189	1.539	90,000	8.07
	mm	31.75	19.05	19.05	9.54	61.4	67.5	122.7	128.8	30.17	4.80	39.10	40,910	12.0
120H-3	inch	1.500	0.875	1.000	0.437	3.01	3.27	6.02	6.28	1.425	0.220	1.925	114,000	13.5
	mm	38.10	22.23	25.40	11.11	76.4	83.0	152.8	159.4	36.20	5.60	48.90	51,820	20.1
140H-3	inch	1.750	1.000	1.000	0.500	3.22	3.51	6.43	6.72	1.663	0.252	2.055	150,000	16.1
	mm	44.45	25.40	25.40	12.71	81.7	89.1	163.4	170.8	42.23	6.40	52.20	68,180	24.0
160H-3	inch	2.000	1.125	1.250	0.563	3.80	4.11	7.61	7.92	1.900	0.280	2.437	180,000	20.7
	mm	50.80	28.58	31.75	14.29	96.6	104.5	193.2	201.1	48.26	7.10	61.90	81,820	30.8
180H-3	inch	2.250	1.406	1.406	0.687	4.25	4.60	8.49	8.85	2.138	0.315	2.724	228,000	30.2
	mm	57.15	35.71	35.71	17.46	107.9	117.0	215.7	224.8	54.30	8.00	69.20	103,635	45.0
200H-3	inch	2.500	1.562	1.500	0.781	4.80	5.20	9.59	10.00	2.375	0.374	3.083	282,000	35.2
	mm	63.50	39.67	38.10	19.85	121.9	132.1	243.7	253.9	60.33	9.50	78.30	128,180	52.5

ASME/ANSI Conveyor Series Double Pitch Roller Chain

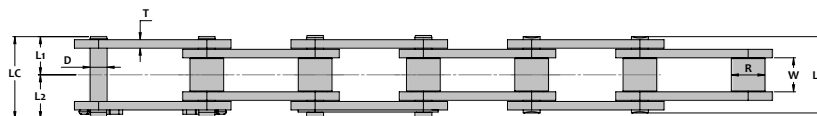

Standard Roller

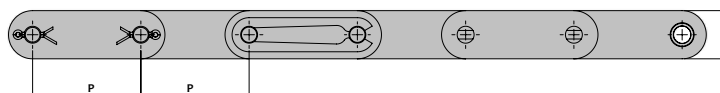

Large Roller

Chain Dimensions - Standard Roller

MAXCO Chain Number	Units	Chain Pitch P	Roller			Pin				Side Plate		Average Ultimate Strength Lbs Kg-f	Rated Working Load	Average Chain Weight Lbs/ft Kg/m
			Dia R	Inside Width W	Dia D	Length				Height H	Thick. T			
						L1	L2	LR	LC					
C2040	inch	1.000	0.312	0.313	0.156	0.35	0.50	0.70	0.85	0.472	0.059	3,750	610	0.33
	mm	25.40	7.92	7.95	3.96	8.9	12.8	17.8	21.7	12.00	1.50	1,705	277	0.49
C2050	inch	1.250	0.400	0.375	0.200	0.43	0.59	0.86	1.02	0.591	0.079	5,900	950	0.56
	mm	31.75	10.16	9.53	5.08	10.9	15.0	21.8	25.9	15.00	2.00	2,680	432	0.84
C2060H	inch	1.500	0.469	0.500	0.234	0.59	0.78	1.19	1.37	0.709	0.126	8,500	1,450	0.97
	mm	38.10	11.91	12.70	5.95	15.1	19.7	30.2	34.8	18.00	3.20	3,865	659	1.45
C2080H	inch	2.000	0.625	0.625	0.312	0.74	0.95	1.47	1.69	0.949	0.157	15,000	2,470	1.62
	mm	50.80	15.88	15.88	7.93	18.7	24.1	37.4	42.8	24.10	4.00	6,820	1,125	2.41
C2100H	inch	2.500	0.750	0.750	0.375	0.88	1.12	1.75	1.99	1.185	0.189	23,500	3,940	2.35
	mm	63.50	19.05	19.05	9.53	22.3	28.4	44.5	50.6	30.10	4.80	10,680	1,790	3.50
C2120H	inch	3.000	0.875	1.000	0.437	1.08	1.34	2.17	2.43	1.425	0.220	33,750	5,250	4.02
	mm	76.20	22.23	25.40	11.10	27.5	34.1	55.0	61.6	36.20	5.60	15,340	2,385	6.00

Chain Dimensions - Large Roller

C2042	inch	1.000	0.625	0.313	0.156	0.35	0.50	0.70	0.85	0.472	0.059	3,750	610	0.58
	mm	25.40	15.88	7.95	3.96	8.9	12.8	17.8	21.7	12.00	1.50	1,705	277	0.86
C2052	inch	1.250	0.750	0.375	0.200	0.43	0.59	0.86	1.02	0.591	0.079	5,900	950	0.89
	mm	31.75	19.05	9.53	5.08	10.9	15.0	21.8	25.9	15.00	2.00	2,680	432	1.32
C2062H	inch	1.500	0.875	0.500	0.234	0.59	0.78	1.19	1.37	0.709	0.126	8,500	1,450	1.46
	mm	38.10	22.23	12.70	5.95	15.1	19.7	30.2	34.8	18.00	3.20	3,865	659	2.17
C2082H	inch	2.000	1.125	0.625	0.312	0.74	0.95	1.47	1.69	0.949	0.157	15,000	2,470	1.92
	mm	50.80	28.58	15.88	7.93	18.7	24.1	37.4	42.8	24.10	4.00	6,820	1,125	2.87
C2102H	inch	2.500	1.562	0.750	0.375	0.88	1.12	1.75	1.99	1.185	0.189	23,500	3,940	3.14
	mm	63.50	39.67	19.05	9.53	22.3	28.4	44.5	50.6	30.10	4.80	10,680	1,790	4.68
C2122H	inch	3.000	1.750	1.000	0.437	1.08	1.34	2.17	2.43	1.425	0.220	33,750	5,250	5.36
	mm	76.20	44.45	25.40	11.10	27.5	34.1	55.0	61.6	36.20	5.60	15,340	2,385	8.00

ASME/ANSI Straight (Flat) Side Bar Roller Chain

ASME/ANSI Straight (Flat) Side Bar roller chains are identical to ASME/ANSI standard chains except that the side bar is straight rather than contoured. These chains are most often used for light to moderate duty material handling conveyors where the side bars are allowed to slide on a conveyor track. The straight side bar design also allows unit materials to sit on top of the chains easily in conveyor applications.

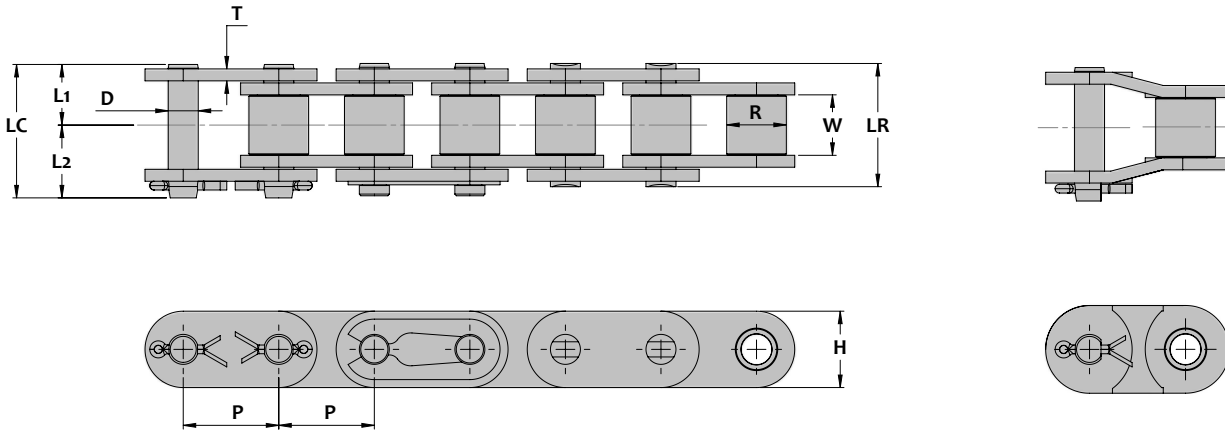

Chain Dimensions

MAXCO Chain Number	Units	Chain Pitch P	Roller			Pin				Side Plate		Average Ultimate Strength Lbs Kg-f	Average Chain Weight Lbs/ft Kg/m
			Dia R	Inside Width W	Dia D	Length			Height H	Thick. T			
						L1	L2	LR			LC		
40F	inch	0.500	0.312	0.313	0.156	0.35	0.50	0.70	0.85	0.475	0.059	4,080	0.44
	mm	12.70	7.92	7.95	3.96	8.9	12.8	17.8	21.7	12.07	1.50	1,855	0.65
50F	inch	0.625	0.400	0.375	0.200	0.43	0.59	0.86	1.02	0.594	0.079	6,830	0.69
	mm	15.88	10.16	9.52	5.09	10.9	15.0	21.8	25.9	15.09	2.0	3,105	1.03
60F	inch	0.750	0.469	0.500	0.235	0.53	0.71	1.06	1.24	0.713	0.094	9,250	0.98
	mm	19.05	11.91	12.70	5.96	13.5	18.1	26.9	31.5	18.10	2.40	4,205	1.46
80F	inch	1.000	0.625	0.625	0.313	0.66	0.87	1.32	1.53	0.950	0.126	17,500	1.64
	mm	25.40	15.88	15.88	7.94	16.8	22.2	33.5	38.9	24.13	3.20	7,955	2.44
100F	inch	1.250	0.750	0.750	0.376	0.81	1.05	1.62	1.86	1.188	0.157	23,000	2.89
	mm	31.75	19.05	19.05	9.54	20.6	26.7	41.1	47.2	30.17	4.00	10,455	4.31

ISO 606B British Standard Straight (Flat) Side Bar Roller Chain

ISO 606B British Standard Straight (Flat) Side Bar roller chains are identical to ISO 606B British Standard chains except that the side bar is straight rather than contoured. These chains are most often used for light to moderate duty material handling conveyors where the side bars are allowed to slide on a conveyor track. The straight side bar design also allows unit materials to sit on top of the chains easily in conveyor applications.

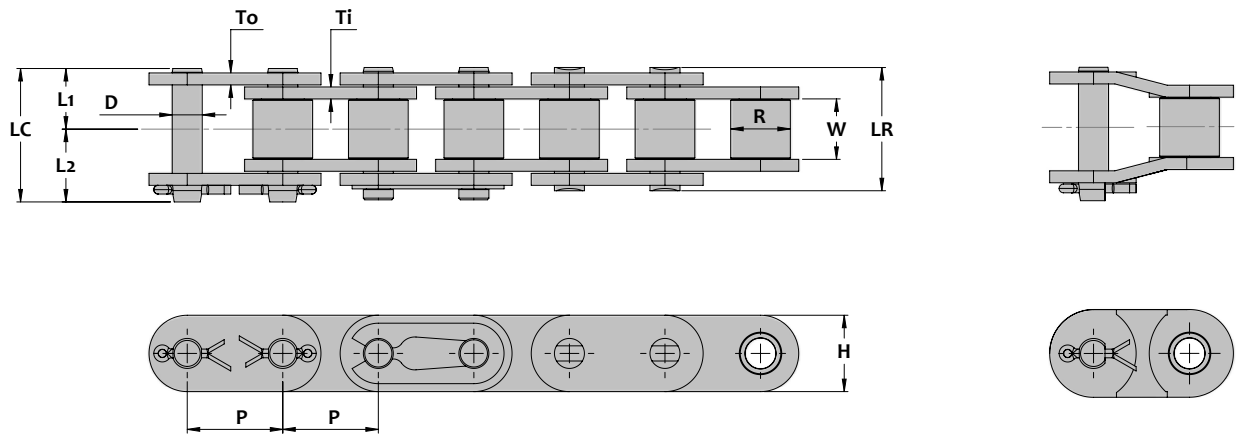

Chain Dimensions

MAXCO Chain Number	Units	Chain Pitch P	Roller		Pin					Side Plate		Average Ultimate Strength Lbs Kg-f	Average Chain Weight Lbs/ft Kg/m	
			Inside Width W	Dia R	Dia D	Length				Height H	Thickness			
						L1	L2	LR	LC		To			Ti
08BF	inch	0.500	0.305	0.335	0.175	0.33	0.49	0.67	0.82	0.465	0.059	4,080	0.50	
	mm	12.70	8.51	8.51	4.45	8.5	12.4	17.0	20.9	11.81	1.50	1,855	0.75	
10BF	inch	0.625	0.400	0.380	0.200	0.39	0.55	0.77	0.93	0.580	0.065	5,500	0.67	
	mm	15.88	10.16	9.65	5.08	9.8	13.9	19.6	23.7	14.73	1.65	2,500	1	
12BF	inch	0.750	0.475	0.460	0.225	0.45	0.63	0.89	1.07	0.635	0.067	0.071	7,100	0.87
	mm	19.05	12.07	11.68	5.72	11.4	16.0	22.7	27.3	16.13	1.70	1.80	3,225	1.29
16BF	inch	1.000	0.625	0.670	0.326	0.71	0.92	1.42	1.63	0.830	0.126	0.157	15,000	1.81
	mm	25.40	15.88	17.02	8.28	18.1	23.5	36.1	41.5	21.08	3.20	4.00	6,820	2.70
20BF	inch	1.250	0.750	0.770	0.400	0.85	1.09	1.70	1.94	1.040	0.138	0.157	23,000	2.85
	mm	31.75	19.05	19.56	10.19	21.6	27.7	43.2	49.3	26.42	3.50	4.00	10,455	4.25
24BF	inch	1.500	1.000	1.000	0.576	1.05	1.31	2.10	2.36	1.315	0.205	0.236	36,500	5.50
	mm	38.10	25.40	25.40	14.63	26.7	33.3	53.4	60.0	33.40	5.20	6.00	16,590	8.20

Nickel Plated Roller Chain

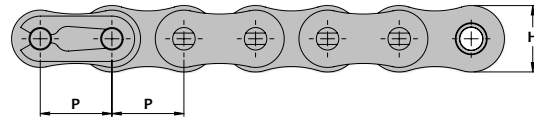
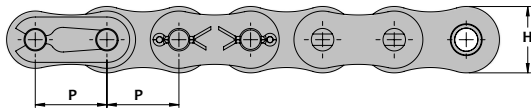
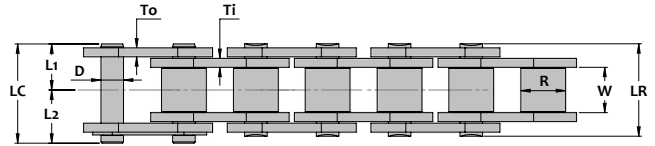
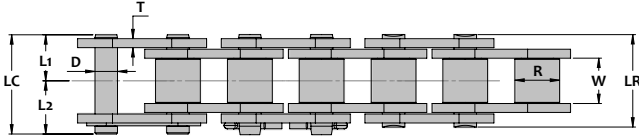

ASME/ANSI Standard

ISO 606B British Standard

Chain Dimensions - ASME/ANSI Standard

MAXCO Chain Number	Units	Chain Pitch P	Roller			Pin				Side Plate		Average Ultimate Strength Lbs Kg-f	Rated Working Load Lbs Kg-f	Average Chain Weight Lbs/ft Kg/m
			Dia.	Inside Width	Dia.	Length				Height	Thick.			
			R	W	D	L1	L2	LR	LC	H	T			
25NP	inch	0.250	0.130	0.125	0.091	0.18	0.28	0.36	0.46	0.237	0.030	880	140	0.09
	mm	6.35	3.20	3.18	2.31	4.6	7.1	9.2	11.7	6.02	0.75	400	64	0.14
35NP	inch	0.375	0.200	0.188	0.141	0.26	0.39	0.52	0.65	0.356	0.049	2,320	475	0.22
	mm	9.525	5.08	4.78	3.58	6.6	9.9	13.2	16.5	9.05	1.25	1,055	216	0.33
40NP	inch	0.500	0.312	0.313	0.156	0.35	0.50	0.70	0.85	0.475	0.059	4,080	800	0.42
	mm	12.70	7.92	7.95	3.96	8.9	12.8	17.8	21.7	12.07	1.50	1,855	364	0.63
50NP	inch	0.625	0.400	0.375	0.200	0.43	0.59	0.86	1.02	0.594	0.079	6,830	1,350	0.68
	mm	15.875	10.16	9.53	5.08	10.9	15.0	21.8	25.9	15.09	2.00	3,105	614	1.01
60NP	inch	0.750	0.469	0.500	0.234	0.53	0.71	1.06	1.24	0.713	0.094	9,250	2,000	0.97
	mm	19.05	11.91	12.70	5.95	13.5	18.1	26.9	31.5	18.10	2.40	4,205	909	1.44
80NP	inch	1.000	0.625	0.625	0.312	0.66	0.87	1.32	1.53	0.950	0.126	17,500	3,200	1.61
	mm	25.4	15.88	15.88	7.93	16.8	22.2	33.5	38.9	24.13	3.20	7,955	1,455	2.40

Chain Dimensions - ISO 606B British Standard

MAXCO Chain Number	Units	Chain Pitch P	Roller		Pin					Side Plate		Average Ultimate Strength Lbs Kg-f	Rated Working Load Lbs Kg-f	Average Chain Weight Lbs/ft Kg/m	
			Inside Width	Dia.	Dia.	Length				Height	Thickness				
			W	R	D	L1	L2	LR	LC	H	To				Ti
06BNP	inch	0.375	0.225	0.250	0.130	0.27	0.40	0.54	0.67	0.325	0.039	0.051	2,100	400	0.26
	mm	9.525	5.72	6.35	3.28	6.8	10.1	13.6	16.9	8.26	1.00	1.30	955	182	0.39
08BNP	inch	0.500	0.305	0.335	0.175	0.33	0.49	0.66	0.82	0.465	0.059		4,080	710	0.62
	mm	12.70	7.75	8.51	4.45	8.5	12.4	17.0	20.9	11.81	1.50		1,855	323	0.92
10BNP	inch	0.625	0.380	0.400	0.200	0.39	0.55	0.78	0.94	0.580	0.065		5,500	1,030	0.83
	mm	15.875	9.65	10.16	5.08	9.8	13.9	19.6	23.7	14.73	1.65		2,500	468	1.24
12BNP	inch	0.750	0.460	0.475	0.225	0.45	0.63	0.90	1.26	0.635	0.067	0.071	7,100	1,210	0.83
	mm	19.05	11.68	12.07	5.7	11.4	16.0	22.8	32.0	16.13	1.70	1.80	3,225	550	1.24
16BNP	inch	1.000	0.670	0.625	0.325	0.71	0.92	1.42	1.63	0.830	0.126	0.157	15,000	3,010	1.78
	mm	25.40	17.02	15.88	8.26	18.1	23.5	36.2	41.6	21.08	3.20	4.00	6,820	1,370	2.65

Nickel Plated Roller Chain

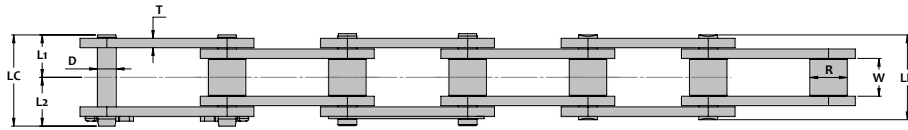

Standard Roller

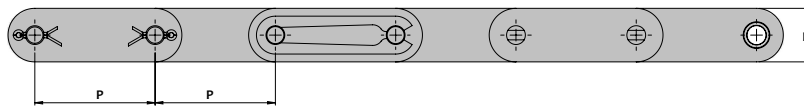

Large Roller

Chain Dimensions - Standard Roller

MAXCO Chain Number	Units	Chain Pitch P	Roller		Dia D	Pin				Side Plate		Average Ultimate Strength Lbs Kg-f	Rated Working Load Lbs Kg-f	Average Chain Weight Lbs/ft Kg/m
			Dia R	Inside Width W		Length	Height H	Thick. T						
									L1	L2	LR			
C2040NP	inch	1.000	0.312	0.313	0.156	0.35	0.50	0.70	0.85	0.472	0.059	3,750	610	0.33
	mm	25.40	7.92	7.95	3.96	8.9	12.8	17.8	21.7	12.00	1.50	1,705	277	0.49
C2050NP	inch	1.250	0.400	0.375	0.200	0.43	0.59	0.86	1.02	0.591	0.079	5,900	990	0.56
	mm	31.75	10.16	9.53	5.08	10.9	15.0	21.8	25.9	15.00	2.00	2,680	450	0.84
C2060HNP	inch	1.500	0.469	0.500	0.234	0.59	0.78	1.19	1.37	0.709	0.126	8,500	1,450	0.97
	mm	38.10	11.91	12.70	5.95	15.1	19.7	30.2	34.8	18.00	3.20	3,865	659	1.45
C2080HNP	inch	2.000	0.625	0.625	0.312	0.74	0.95	1.47	1.69	0.949	0.157	15,000	2,470	1.62
	mm	50.80	15.88	15.88	7.93	18.7	24.1	37.4	42.8	24.10	4.00	6,820	1,125	2.41

Chain Dimensions - Large Roller

C2042NP	inch	1.000	0.625	0.313	0.156	0.35	0.50	0.70	0.85	0.472	0.059	3,750	610	0.58
	mm	25.40	15.88	7.95	3.96	8.9	12.8	17.8	21.7	12.00	1.50	1,705	277	0.86
C2052NP	inch	1.250	0.750	0.375	0.200	0.43	0.59	0.86	1.02	0.591	0.079	5,900	990	0.89
	mm	31.75	19.05	9.53	5.08	10.9	15.0	21.8	25.9	15.00	2.00	2,680	450	1.32
C2062HNP	inch	1.500	0.875	0.500	0.234	0.59	0.78	1.19	1.37	0.709	0.126	8,500	1,450	1.46
	mm	38.10	22.23	12.70	5.95	15.1	19.7	30.2	34.8	18.00	3.20	3,865	659	2.17
C2082HNP	inch	2.000	1.125	0.625	0.312	0.74	0.95	1.47	1.69	0.949	0.157	15,000	2,470	1.92
	mm	50.80	28.58	15.88	7.93	18.7	24.1	37.4	42.8	24.10	4.00	6,820	1,125	2.87

304 Stainless Steel Roller Chain

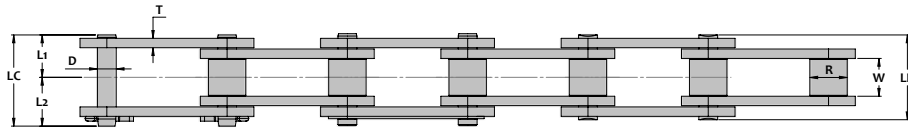

Standard Roller

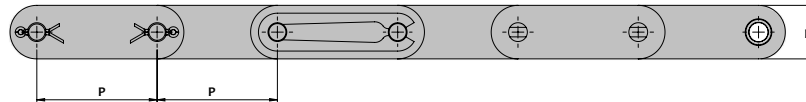

Large Roller

Chain Dimensions - Standard Roller

MAXCO Chain Number	Units	Chain Pitch P	Roller			Pin				Side Plate		Average Ultimate Strength Lbs Kg-f	Rated Working Load Lbs Kg-f	Average Chain Weight Lbs/ft Kg/m
			Dia R	Inside Width W	Dia D	Length				Height H	Thick. T			
C2040SS	inch	1.000	0.312	0.313	0.156	0.35	0.50	0.70	0.85	0.472	0.059	2,790	100	0.33
	mm	25.40	7.92	7.95	3.96	8.9	12.8	17.8	21.7	12.00	1.50	1,270	45	0.49
C2050SS	inch	1.250	0.400	0.375	0.200	0.43	0.59	0.86	1.02	0.591	0.079	4,560	150	0.56
	mm	31.75	10.16	9.53	5.08	10.9	15.0	21.8	25.9	15.00	2.00	2,075	68	0.84
C2060HSS	inch	1.500	0.469	0.500	0.234	0.59	0.78	1.19	1.37	0.709	0.126	6,160	250	0.97
	mm	38.10	11.91	12.70	5.95	15.1	19.7	30.2	34.8	18.00	3.20	2,800	114	1.45
C2080HSS	inch	2.000	0.625	0.625	0.312	0.74	0.95	1.47	1.69	0.949	0.157	10,590	420	1.62
	mm	50.80	15.88	15.88	7.93	18.7	24.1	37.4	42.8	24.10	4.00	4,815	191	2.41
C2100HSS	inch	2.500	0.750	0.750	0.375	0.88	1.12	1.75	1.99	1.185	0.189	12,790	600	2.35
	mm	63.50	19.05	19.05	9.53	22.3	28.4	44.5	50.6	30.10	4.80	5,815	273	3.50
C2120HSS	inch	3.000	0.875	1.000	0.437	1.08	1.34	2.17	2.43	1.425	0.220	17,200	900	4.02
	mm	76.20	22.23	25.40	11.10	27.5	34.1	55.0	61.6	36.20	5.60	7,820	409	6.00

Chain Dimensions - Large Roller

C2042SS	inch	1.000	0.625	0.313	0.156	0.35	0.50	0.70	0.85	0.472	0.059	2,790	100	0.58
	mm	25.40	15.88	7.95	3.96	8.9	12.8	17.8	21.7	12.00	1.50	1,270	45	0.86
C2052SS	inch	1.250	0.750	0.375	0.200	0.43	0.59	0.86	1.02	0.591	0.079	4,560	150	0.89
	mm	31.75	19.05	9.53	5.08	10.9	15.0	21.8	25.9	15.00	2.00	2,075	68	1.32
C2062HSS	inch	1.500	0.875	0.500	0.234	0.59	0.78	1.19	1.37	0.709	0.126	6,160	250	1.46
	mm	38.10	22.23	12.70	5.95	15.1	19.7	30.2	34.8	18.00	3.20	2,800	114	2.17
C2082HSS	inch	2.000	1.125	0.625	0.312	0.74	0.95	1.47	1.69	0.949	0.157	10,590	420	1.92
	mm	50.80	28.58	15.88	7.93	18.7	24.1	37.4	42.8	24.10	4.00	4,815	191	2.87
C2102HSS	inch	2.500	1.562	0.750	0.375	0.88	1.12	1.75	1.99	1.185	0.189	12,790	600	3.14
	mm	63.50	39.67	19.05	9.53	22.3	28.4	44.5	50.6	30.10	4.80	5,815	273	4.68
C2122HSS	inch	3.000	1.750	1.000	0.437	1.08	1.34	2.17	2.43	1.425	0.220	17,200	900	5.36
	mm	76.20	44.45	25.40	11.10	27.5	34.1	55.0	61.6	36.20	5.60	7,820	409	8.00

ASME/ANSI AL Series Leaf Chain

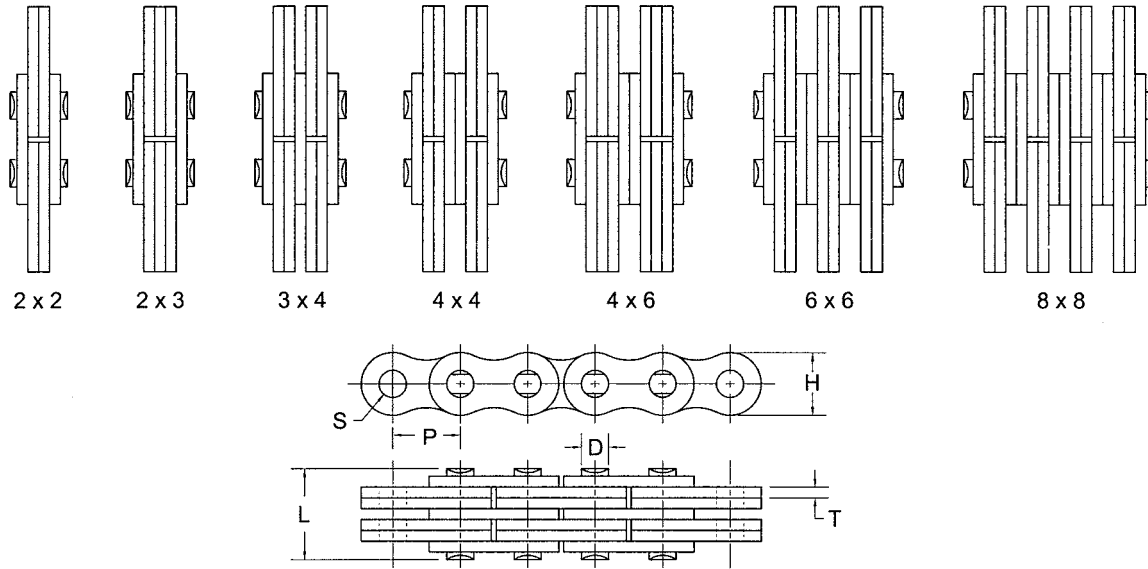

Chain Dimensions

MAXCO Chain Number	Units	Lacing	Chain Pitch P	Pin		Side Plate		Hole Dia. S	Minimum Ultimate Strength Lbs Kg-f	Average Ultimate Strength Lbs Kg-f	Average Chain Weight Lbs/ft Kg/m
				Dia D	Length L1	Height H	Thick. T				
AL422	inch	2 x 2	0.500	0.157	0.33	0.410	0.062	0.1575	3,300	3,970	0.24
	mm		12.70	3.98	8.4	10.41	1.57	4.00	1,500	1,805	0.36
AL444	inch	4 x 4			0.59				6,600	7,940	0.48
	mm				14.9				3,000	3,610	0.71
AL466	inch	6 x 6			0.84				9,900	11,900	0.82
	mm				21.3				4,500	5,410	1.22
AL522	inch	2 x 2	0.625	0.200	0.43	0.513	0.082	0.2016	5,500	6,830	0.42
	mm		15.875	5.09	11.0	13.03	2.08	5.12	2,500	3,105	0.63
AL544	inch	4 x 4			0.77				11,000	13,670	0.82
	mm				19.5				5,000	6,215	1.23
AL566	inch	6 x 6			1.10				16,500	27,340	1.41
	mm				28.0				7,500	12,425	2.10
AL622	inch	2 x 2	0.750	0.235	0.51	0.615	0.096	0.2354	7,500	9,700	0.60
	mm		19.05	5.96	12.9	15.62	2.44	5.98	3,410	4,410	0.90
AL644	inch	4 x 4			0.90				15,000	19,400	1.18
	mm				22.8				6,820	8,820	1.76
AL666	inch	6 x 6			1.29				22,500	29,100	2.03
	mm				32.7				10,225	13,225	3.03
AL822	inch	2 x 2	1.000	0.313	0.68	0.820	0.130	0.3134	13,000	16,750	0.99
	mm		25.40	7.94	17.4	20.83	3.30	7.96	5,910	7,615	1.48
AL844	inch	4 x 4			1.21				26,000	33,510	1.96
	mm				30.8				11,820	15,230	2.92
AL866	inch	6 x 6			1.74				39,000	50,260	3.33
	mm				44.2				17,725	22,845	4.97

ASME/ANSI BL Series Leaf Chain

Chain Dimensions

MAXCO Chain Number	Units	Lacing	Chain Pitch P	Pin		Side Plate		Hole Dia. S	Minimum Ultimate Strength Lbs Kg-f	Average Ultimate Strength Lbs Kg-f	Average Chain Weight Lbs/ft Kg/m
				Dia D	Length L1	Height H	Thick. T				
BL423	inch	2 x 3	0.500	0.200	0.52	0.475	0.082	0.2016	5,000	6,610	0.52
	mm		12.70	5.09	13.2	12.07	2.08	5.12	2,275	3,005	0.77
BL434	inch	3 x 4			0.69				7,500	9,920	0.72
	mm				17.4				3,410	4,510	1.07
BL444	inch	4 x 4			0.77				10,000	13,230	0.80
	mm				19.5				4,545	6,015	1.19
BL446	inch	4 x 6			0.94				10,000	13,230	0.99
	mm				23.8				4,545	6,015	1.48
BL466	inch	6 x 6			1.10				15,000	19,840	1.21
	mm				28.0				6,820	9,020	1.80
BL523	inch	2 x 3	0.625	0.234	0.61	0.594	0.096	0.2354	7,500	9,700	0.76
	mm		15.875	5.96	15.4	15.09	2.44	5.98	3,410	4,410	1.13
BL534	inch	3 x 4			0.80				11,000	14,550	1.05
	mm				20.3				5,000	6,615	1.56
BL544	inch	4 x 4			0.90				15,000	19,400	1.19
	mm				22.8				6,820	8,820	1.78
BL546	inch	4 x 6			1.09				15,000	19,400	1.49
	mm				27.7				6,820	8,820	2.22
BL566	inch	6 x 6			1.29				22,500	29,100	1.84
	mm				32.7				1,025	13,225	2.74
BL623	inch	2 x 3	0.750	0.312	0.82	0.713	0.130	0.3134	14,300	15,430	1.22
	mm		19.05	7.94	20.7	18.11	3.30	7.96	6,500	7,015	1.82
BL634	inch	3 x 4			1.08				21,500	23,150	1.69
	mm				27.4				9,775	10,525	2.52
BL644	inch	4 x 4			1.21				28,700	30,870	1.92
	mm				30.8				13,045	14,030	2.87
BL646	inch	4 x 6			1.48				28,700	30,870	2.39
	mm				37.5				13,045	14,030	3.57
BL666	inch	6 x 6			1.74				42,800	46,300	2.86
	mm				44.2				19,455	21,045	4.27
BL823	inch	2 x 3	1.000	0.376	1.00	0.950	0.161	0.3764	19,000	25,350	2.11
	mm		25.40	9.54	25.5	24.13	4.09	9.56	8,618	11,525	3.15
BL834	inch	3 x 4			1.33				29,000	38,030	2.93
	mm				33.8				13,154	17,285	4.37
BL844	inch	4 x 4			1.49				38,000	50,710	3.34
	mm				37.9				17,236	23,050	4.98
BL846	inch	4 x 6			1.82				38,000	50,710	4.16
	mm				46.2				17,236	23,050	6.20
BL866	inch	6 x 6			2.14				57,000	76,060	5.03
	mm				54.5				25,854	34,575	7.50

ASME/ANSI BL Series Leaf Chain

Chain Dimensions

MAXCO Chain Number	Units	Lacing	Chain Pitch P	Pin		Side Plate		Hole Dia. S	Minimum Ultimate Strength Lbs Kg-f	Average Ultimate Strength Lbs Kg-f	Average Chain Weight Lbs/ft Kg/m
				Dia D	Length L1	Height H	Thick. T				
BL1023	inch	2 x 3	1.250	0.437	1.19	1.188	0.193	0.4386	26,000	34,170	2.58
	mm		31.75	11.10	30.3	30.18	4.90	11.14	11,820	15,530	3.85
BL1034	inch	3 x 4			1.58				39,000	51,260	3.92
	mm				40.2				17,725	23,300	5.84
BL1044	inch	4 x 4			1.78				52,000	68,340	4.83
	mm				45.2				23,635	31,065	7.20
BL1046	inch	4 x 6			2.17				52,000	68,340	4.18
	mm				55.1				23,635	31,065	6.24
BL1066	inch	6 x 6			2.56				78,000	102,510	7.13
	mm				65.0				35,455	46,595	10.6
BL1223	inch	2 x 3	1.500	0.500	1.39	1.425	0.227	0.5016	34,000	45,200	4.39
	mm		38.10	12.7	35.4	36.20	5.77	12.74	15,455	30,815	6.54
BL1234	inch	3 x 4			1.85				51,000	67,790	6.10
	mm				47.1				23,180	41,085	9.10
BL1244	inch	4 x 4			2.08				68,000	90,390	6.97
	mm				52.9				30,910	41,085	10.4
BL1246	inch	4 x 6			2.54				68,000	90,390	8.05
	mm				64.5				30,910	61,625	12.0
BL1266	inch	6 x 6			3.00				102,000	135,580	9.78
	mm				76.2				46,365	26,055	14.6
BL1423	inch	2 x 3	1.750	0.562	1.58	1.663	0.258	0.5634	43,000	57,320	6.07
	mm		44.45	14.28	40.2	42.24	6.55	14.31	19,545	39,080	9.05
BL1434	inch	3 x 4			2.10				64,500	85,980	8.45
	mm				53.4				29,320	52,110	12.6
BL1444	inch	4 x 4			2.36				86,000	114,640	9.66
	mm				60.0				39,090	52,110	14.4
BL1446	inch	4 x 6			2.88				86,000	114,640	12.1
	mm				73.2				39,090	52,110	18.0
BL1466	inch	6 x 6			3.40				129,000	171,960	14.4
	mm				86.4				58,635	78,165	21.5
BL1623	inch	2 x 3	2.000	0.687	1.83	1.900	0.296	0.6886	65,000	72,750	8.12
	mm		50.80	17.45	46.6	48.26	7.52	17.49	29,545	33,070	12.1
BL1634	inch	3 x 4			2.43				97,500	114,640	11.3
	mm				61.7				44,320	52,110	16.9
BL1644	inch	4 x 4			2.73				130,000	145,500	12.9
	mm				69.3				59,090	66,135	19.2
BL1646	inch	4 x 6			3.32				130,000	145,500	16.0
	mm				84.4				59,090	66,135	23.9
BL1666	inch	6 x 6			3.92				195,000	218,260	19.3
	mm				99.6				88,635	99,210	28.7

ISO LL Series Leaf Chain

Chain Dimensions

MAXCO Chain Number	Units	Lacing	Chain Pitch P	Pin		Side Plate		Hole Dia. S	Minimum Ultimate Strength Lbs Kg-f	Average Chain Weight Lbs/ft Kg/m
				Dia D	Length L1	Height H	Thick. T			
LL0822	inch	2 x 2	0.500	0.175	0.33	0.430	0.061	0.1756	4,000	0.24
	mm		12.70	4.45	8.5	10.92	1.55	4.46	1,820	0.36
LL0844	inch	4 x 4			0.57				6,990	0.46
	mm				14.6				3,175	0.69
LL0866	inch	6 x 6			0.81				10,000	0.70
	mm				20.7				4,545	1.05
LL1022	inch	2 x 2	0.625	0.200	0.37	0.540	0.065	0.2004	4,990	0.34
	mm		15.875	5.08	9.3	13.72	1.65	5.09	2,270	0.50
LL1044	inch	4 x 4			0.63				10,000	0.67
	mm				16.1				4,545	1.00
LL1066	inch	6 x 6			0.90				15,000	0.99
	mm				22.9				6,820	1.48
LL1222	inch	2 x 2	0.750	0.225	0.42	0.635	0.075	0.2256	6,500	0.50
	mm		19.05	5.72	10.7	16.13	1.90	5.73	2,955	0.74
LL1244	inch	4 x 4			0.73				12,990	0.97
	mm				18.5				5,905	1.45
LL1266	inch	6 x 6			1.04				19,490	1.45
	mm				26.3				8,860	2.16
LL1622	inch	2 x 2	1.000	0.326	0.68	0.830	0.126	0.3268	13,040	1.05
	mm		25.40	8.28	17.2	21.08	3.20	8.30	5,925	1.57
LL1644	inch	4 x 4			1.19				26,080	2.07
	mm				30.2				11,855	3.09
LL1666	inch	6 x 6			1.70				39,120	3.08
	mm				43.2				17,780	4.60
LL2022	inch	2 x 2	1.250	0.401	0.79	1.040	0.146	0.4020	21,360	1.35
	mm		31.75	10.19	20.1	26.42	3.70	10.21	9,710	2.01
LL2044	inch	4 x 4			1.38				42,710	2.64
	mm				35.1				19,415	3.93
LL2066	inch	6 x 6			1.97				64,070	3.93
	mm				50.1				29,125	5.86
LL2422	inch	2 x 2	1.500	0.576	1.12	1.315	0.205	0.5768	38,220	2.80
	mm		38.10	14.63	28.4	33.40	5.20	14.65	17,375	4.18
LL2444	inch	4 x 4			1.94				76,430	5.69
	mm				49.4				34,740	8.48
LL2466	inch	6 x 6			2.77				114,650	8.18
	mm				70.4				52,115	12.20
LL2822	inch	2 x 2	1.750	0.626	1.34	1.460	0.254	0.6268	44,960	3.49
	mm		44.45	15.90	34.0	37.08	6.45	15.92	20,435	5.20
LL2844	inch	4 x 4			2.36				89,920	6.77
	mm				68.0				40,875	10.1
LL2866	inch	6 x 6			3.39				134,890	9.99
	mm				86.0				61,315	14.9
LL3222	inch	2 x 2	2.000	0.701	1.38	1.665	0.245	0.7020	58,450	4.71
	mm		50.80	17.81	35.0	42.29	6.45	17.83	26,570	7.02
LL3244	inch	4 x 4			2.40				116,900	8.62
	mm				61.0				53,135	12.9
LL3266	inch	6 x 6			3.43				175,350	12.4
	mm				87.0				79,705	18.4

Installation, Lubrication and Maintenance

Introduction

Certain minimum standards for installing and maintaining roller chains are assumed in designing, producing and specifying these products for service. If reasonable attention is paid to a few installation and maintenance procedures, roller chains will generally provide years of trouble free service life.

The following guidelines are intended to help users get the most out of their roller chain purchase. We note that this information is offered only as a guide. Original Equipment Manufacturers may offer information that conflicts with some items in this section. In these cases the user should follow the maintenance procedures as outlined by the Original Equipment Manufacturer.

Steps Recommended for Installing Roller Chains on Drives

Please review the following steps when installing a new roller chain drive:

1. Make sure all components are in good running condition.
2. Make sure sprockets and shafts are properly aligned.
3. Connect the chain on the sprockets.
4. Assure correct lubrication per the Original Equipment Manufacturers suggestion or lacking that the guidelines available in the lubrication portion of this section.
5. Adjust the chain tension properly.
6. Assure appropriate Guarding is in place.

WARNING - SAFETY INFORMATION

1. ALWAYS lock out equipment power switch before removing or installing roller chains.
2. ALWAYS use safety glasses to protect your eyes.
3. Wear protective clothing, gloves and safety shoes as appropriate.
4. Support the equipment to prevent uncontrolled movement of the roller chain and parts.
5. Use pressing equipment if possible to remove or install press fit type links. Tooling must be in good condition and properly used.
6. Do not attempt to connect or disconnect a roller chain unless you know the chain's construction including the correct direction for connecting link removal or insertion.

Condition of Components

All components including chains, sprockets, shafts, bearing etc. should be in good running condition. Make sure that parts that exhibit excessive wear are replaced. We recommend new chains operate on new sprocket tooth faces when possible. Sometimes this can be accomplished by rotating the sprocket end for end, on non reversing drives, so that the driving surface of the tooth is "unused".

Alignment of Shafts and Sprockets

Correct shaft and sprocket alignment is necessary to prevent uneven loading which can damage chains and sprocket tooth faces. Often improper alignment will manifest itself in rapid chain elongation or unusual wear on the chain link plates and/or sprocket teeth.

There are two necessary steps to achieve proper alignment as follows:

1. Make sure the shafts are parallel to each other.
2. Make sure the sprockets are "in line" with one another and not offset.

Tolerances for shaft parallelism and sprocket alignment are as follows:

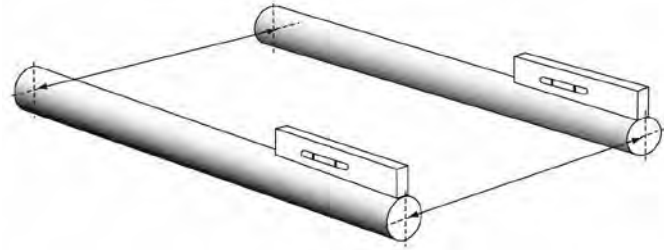

Shaft Alignment

Shafts should be parallel within fairly close limits. We suggest using a machinist's level or feeler bar to make sure the shafts are located in the same plane. If shafts can move axially, lock them in place before attempting to align them.

Tolerance for Shaft Alignment

For single strand roller chain drives:

$$\text{Tolerance} = 0.050 \text{ inch/ft (4.2mm per meter) or } 1/4 \text{ degree}$$

For high speed, high horsepower or multiple strand roller chain drives, use the following formula:

$$\text{Tolerance} = 0.00133 \times C / (P \times n) \text{ [Units: in/ft]}$$

or

$$\text{Tolerance} = 0.111 \times c / (P \times n) \text{ [Units: mm/m]}$$

Note that: C = shaft center distance (inches or millimeters).

P = Chain pitch (inches or millimeters).

n = number of chain strands.

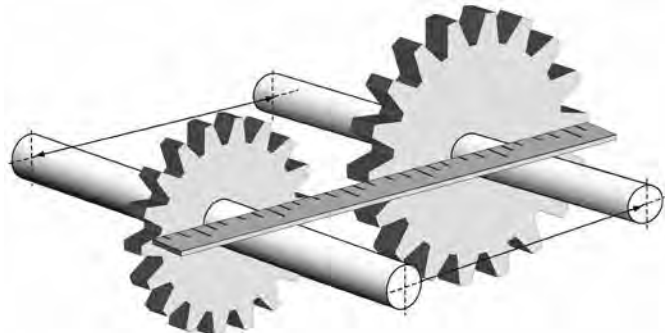

Sprocket Alignment

A straight edge or piano wire or other precision aligning tool to be sure the sprockets are not offset from one another.

Tolerance for Sprocket Alignment

$$\text{Maximum Offset} = 0.045 \times P \text{ (inches or millimeters)}$$

Note that: P = Chain pitch (inches or millimeters).

Installation, Lubrication and Maintenance

Chain Tension Adjustment

The correct amount of slack in a roller chain drive is necessary for smooth operation. Measurement of mid-span movement is the best way to check that the chain is properly tensioned. After rotating one sprocket so that one side of the chain is tight use a straight edge to measure the movement of the slack side. Adjust center distances or idlers to achieve approximately 4% - 6% mid span movement (vs. the drives center distance) for horizontal to 45° inclined drives and 2% - 3% for drives that are inclined 45° to vertical or for drives that are subjected to high shock loadings.

Recommended Mid-Span Movement

Drive Position	Tangent Length Between Sprockets Inches - (millimeters)					
	10 (25.4)	20 (50.8)	30 (76.2)	50 (127)	70 (177.8)	100 (254)
Horizontal to 45 degrees	0.4 - 0.6 (10 - 15)	0.8 - 1.2 (20 - 30)	1.2 - 1.8 (30 - 46)	2.0 - 3.0 (51 - 76)	2.8 - 4.2 (71 - 107)	4.0 - 6.0 (102 - 152)
45 degrees to Vertical	0.2 - 0.3 (5 - 8)	0.4 - 0.6 (10 - 15)	0.6 - 0.9 (15 - 35)	1.0 - 1.5 (25 - 38)	1.4 - 2.1 (36 - 53)	2.0 - 3.0 (51 - 76)

Movement of Slack Side of Chain

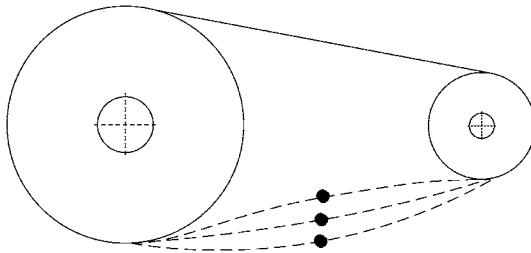

Lubrication

The most effective way to assure long trouble free chain life is with effective lubrication. The correct selection of oil viscosity and the method of application depends on chain speed, chain load and ambient temperatures. We recommend the use of high quality non-detergent motor oils for most applications. Additives in oil can cause sludge build up and reduce the effectiveness of lubrication by preventing full penetration into the chain joint.

In general, the highest viscosity oil which, under the conditions of the drive (particularly its temperature) that can successfully penetrate into the chain pin/bushing bearing area will form the thickest film and offer the best protection to the drive. This film will help improve chain life by slowing the rate of wear elongation. Oils should be applied to the inside portion of the chain on the slack side - This will help prevent the oil from being thrown off by centrifugal force. In addition be sure to apply the oil between the link plates to lubricate the pin/bushing bearing area and at the roller edges to lubricate the inside diameter of the roller.

Please see the following illustrations:

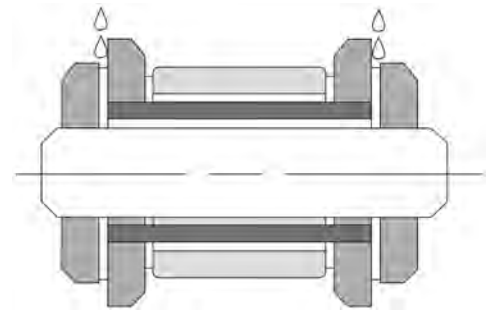
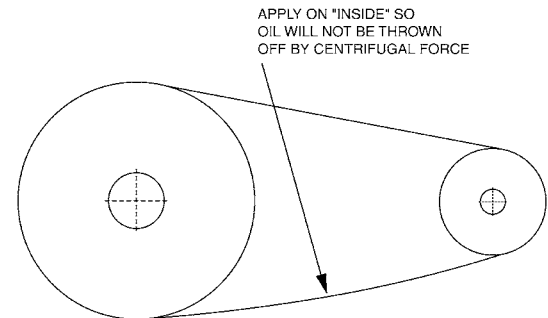

Lubricate Between Link Plates and Roller Edges

Recommended Oil Viscosity vs Operating Temperature

Lubricants for roller chain drives should have the following qualities:

1. Low enough viscosity to effectively penetrate into the internal bearing surfaces.
2. High enough viscosity to provide and maintain a sufficient film of lubricant under the existing load conditions.
3. Be free and clean of corrodents or containments.
4. Have the ability to maintain good lubricating properties under the existing load and environmental conditions of the drive.

The following table provides suggested grades of oil at various operating temperatures:

Allowable Oil Viscosity vs Operating Temperatures

Recommended Grade of Oil	Temperature (°F)	4Temperature (°C)
SAE 5	-50°F - 50°F	-46°C - 10°C
SAE 10	-20°F - 80°F	-29°C - 27°C
SAE 20	10°F - 110°F	-12°C - 43°C
SAE 30	20°F - 130°F	-7°C - 54°C
SAE 40	30°F - 140°F	-1°C - 60°C
SAE 50	40°F - 150°F	4°C - 65°C

Installation, Lubrication and Maintenance

Methods of Application For Lubricants

In the horsepower tables three types of lubricant application methods are included as part of the drive chain selection procedure for ASME/ANSI roller chains. They are:

- Type A: Manual or Drip Lubrication
- Type B: Oil Bath or Slinger Disc Lubrication
- Type C: Oil Stream or Pressure Spray Lubrication

This means that the roller chain is rated at a certain horsepower capacity provided the correct lubricant application method is followed. If these requirements are ignored severe reductions in chain life can result.

In general the lubricant application method will depend mostly on chain speed so that slow speed drives are lubricated manually or by automatic drip (Type A), moderate speed drives are lubricated in an oil bath or with a slinger disc (Type B) and high speed drives utilize pressure spray type applicators (Type C)

Manual Lubrication (Type A)

IMPORTANT: Manual lubrication is to be applied only when the drive chain is stopped and the motor power is locked out.

Oil is applied periodically with a brush or oil spout can. Lubrication once every eight hours of operation is suggested however the frequency should be adjusted as necessary to prevent the formation of red rust and oil dis-colorization. If dis-colorization is noted the chain should be removed, cleaned, re-lubricated and the lubrication frequency and/or amount should be increased.

Drip Lubrication (Type A)

Oil is dripped between the link plates and at the roller edges at some regular rate from a drip lubricator. Drip rates may vary from 4 - 20 drops per minute depending on chain speed and load. As with manual lubrication the rate at which oil is applied should be sufficient to prevent red rust or any dis-colorization of the oil. Care should be taken that wind does not misdirect the oil drops. Also oil reservoir levels should be periodically checked to be sure that they do not run dry and thus fail to lubricate the chain.

Multiple strand chains require a distribution pipe which can feed oil to all the rows of the link plates. A wick packed distribution pipe is often required for this purpose as illustrated below:

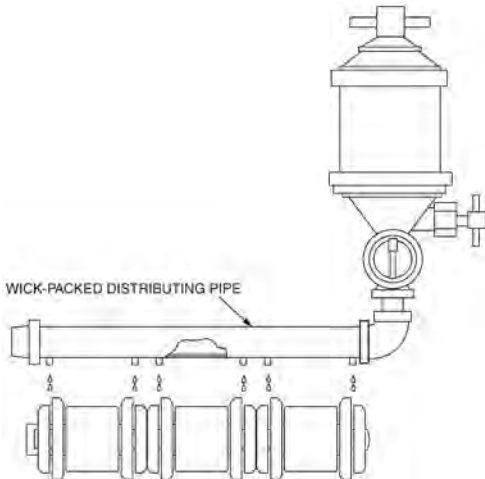

Oil Bath Lubrication (Type B)

A short section of chain runs through an oil sump at the bottom of the chain casing. The level of oil should reach the pitch line of the chain at it's lowest point of operation. Horizontal or nearly horizontal drives that require long sections of chain to run through the bath are not ideal candidates for this type of lubrication method. Oil foaming and/ or overheating of the oil can result when long sections of chain run through the bath.

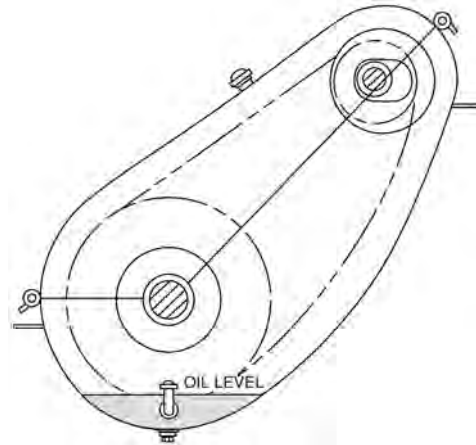

Typical Oil Bath Lubrication Method

Slinger Disc Lubricator (Type B)

In a slinger disc lubrication system the chain operates above the level of the oil and a disc mounted dips into the oil and "slings" it onto a collector plate. The oil then runs through a trough or gutter and is distributed to the chain. The diameter of the disc should be sized to produce linear speeds at the rim of between 600ft/min - 800ft/min. Lower speeds may not effectively pick up the oil and higher speeds may cause over heating or foaming of the oil.

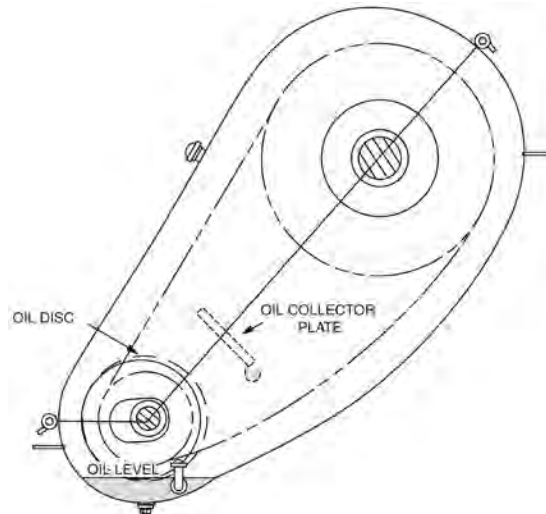

Typical Oil Slinger Disc Type Lubrication Method

Installation, Lubrication and Maintenance

Notes on Type B Lubrication

In both the oil bath and slinger disc lubrication methods the temperature of both the oil and the chain should not exceed 180°F (82°C). The volume of oil provided to the chain should be sufficient to prevent dis-colorization. After approximately eight hours of operation in both devices should be checked and filled as required. In addition the lubrication system should be checked for leaks, oil foaming or overheating at each inspection period.

Oil Stream or Pressure Spray Lubrication (Type C)

In this system an oil pump delivers oil under pressure to, usually through a flexible hose, to nozzles, that direct a stream or spray of oil onto the chain. The oil should be delivered evenly across the entire chain width (especially important for multiple chain strands). As with other lubrication methods this stream is also applied on the inside of the slack portion of the chain strand.

Excess oil collects at the bottom of the chain casing and is returned to the pump's reservoir. Cooling may be accomplished by the dissipation of heat through the chain casing or by a heat exchanger. Oil levels should be checked at some regular interval (every 8 hours for example) and filled as required. As with other lubrication methods the system should be checked for leaks, foaming of the oil or overheating.

A typical Pressure spray lubrication system is illustrated below:

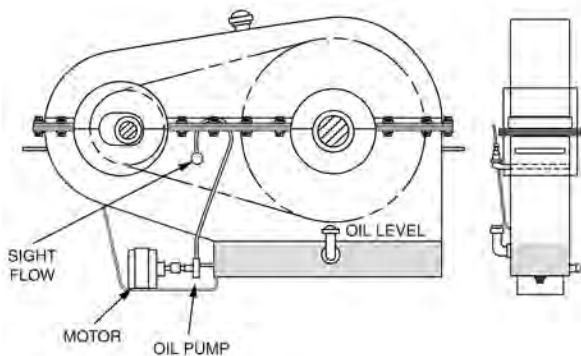

Typical Pressure Spray Type Lubrication Method

Oil Flow Requirements for Oil Stream or Pressure Spray Devices

The table below gives the required oil flow necessary in a typical Oil Stream or Pressure Spray lubrication system according to the power transmitted by the drive.

Transmitted Power		Minimum Oil Required		Transmitted Power		Minimum Oil Required	
HP	KW	gal/min	liter/min	HP	KW	gal/min	liter/min
50	37	0.25	0.95	500	373	2.50	9.46
100	75	0.50	1.89	600	447	3.00	11.40
150	112	0.75	2.84	800	597	3.75	14.20
200	149	1.00	3.78	1,000	746	4.75	18.00
300	224	1.50	5.68	1,500	1,119	7.00	26.50
400	298	2.00	7.57	2,000	1,491	10.00	37.90

Drive Chain Maintenance

In order to obtain maximum service life a maintenance plan should be developed that assures the following:

1. The drive must be effectively lubricated.
2. Damaged or worn out chains, sprockets, bearings or other components are replaced.
3. Sprockets and shafts are properly aligned.
4. Chains are correctly tensioned.
5. Any interferences are eliminated.
6. Appropriate guarding is in place and properly installed.

Roller Chains should be inspected after the first 50 hours of operation for the following:

1. Damage to chains or sprocket teeth.
2. Excessive chain and/or sprocket wear.
3. Interferences that can be identified by unusual noise or unusual wear marks or gouge marks on the chain itself.
4. Correctly functioning lubrication system.
5. Proper chain tension (adjust if necessary).

Chain Wear

In most Roller Chain drive applications the chain is considered worn out when it has elongated 2% - 3% over its original length. Since elongation is caused most typically by pin/bushing wear these components will have become weakened and in need of replacement. In addition as the chain gets longer it may not operate over the sprocket correctly.

On drives with sprockets that have more than 100 teeth the maximum allowable elongation is less than 2% and is given by the following formula:

$$\text{Maximum Elongation Percentage} = 200 / N$$

N is the number of teeth on the largest sprocket. If for example the number of teeth on the large sprocket is 120 then the maximum allowable wear elongation is:

$$200 / 120 = 1.67\%$$

When measuring the length of a chain use a pair of calipers and measure an even number of pitches (8 Pitches or greater) on the tight side of the chain strand.

Sprocket Tooth Wear

The following may indicate that the sprocket teeth are worn out and that the sprocket should be replaced:

1. Sprocket teeth appear hooked.
2. Sprocket tooth thickness is reduced by 10% or more
3. Binding or clinging when the chain is new. This can be noted as the chain engages and disengages the sprocket.

Drive Configurations

Horizontal Drives

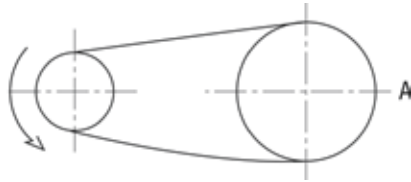

A. Slack Adjusted. The slack on the bottom side provides the pretension for the drive.

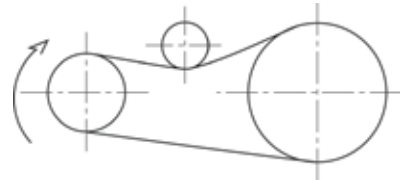

B. When the chain slack is on the upper side, a chain tensioner is used to provide the pretension for the drive.

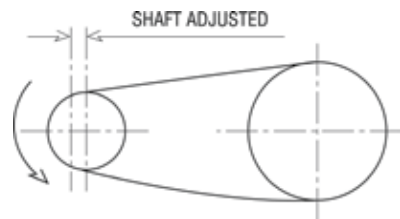

C. For short center distances (20 pitches or less) an adjustable jack shaft may be used so that the adjustable centers provide the pretension for the drive.

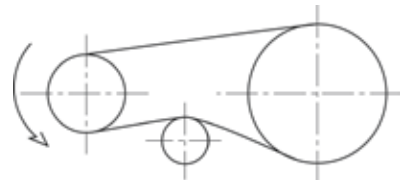

D. If center distance is long (50 pitches or more) a chain tensioner is required to apply pretension to the chain drive.

Inclined Drives

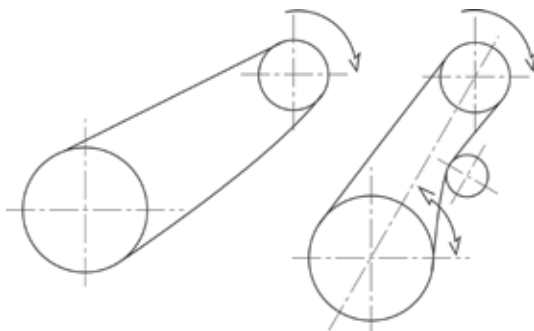

E. The incline angle should not exceed 60° without a chain tensioner.

F. A Chain tensioner is used for incline drives if the incline angle is greater than 60° or excess slack causes the chain to fall off the bottom sprocket.

Vertical Drives

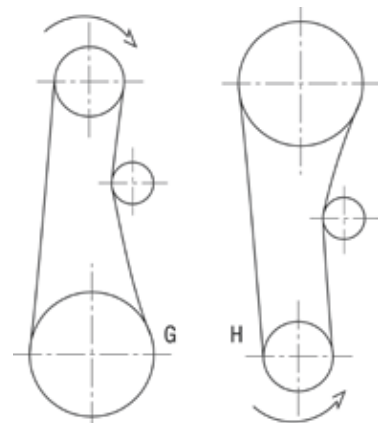

G. When a large sprocket is on the bottom of a vertical drive a chain tensioner is suggested so that the chain does not fall off the bottom sprocket.



H. When the small sprocket is on the bottom of a vertical drive a chain tensioner is required.

Trouble Shooting Guide

Trouble Shooting Guide

The table below lists some causes and remedies for common chain drive problems.

Problem	Possible Causes	Suggested Remedies
Excessive Noise	<ul style="list-style-type: none"> • Misalignment • Excessive slack • Chain and/or sprockets worn out • Too few sprocket teeth • Inadequate Lubrication • Obstruction • Loose casing or shaft mounts 	<ul style="list-style-type: none"> • Align shafts and sprockets • Adjust chain tension • Replace chain and/or sprockets • Re-size chain drive • Lubricate properly • Remove obstruction • Tighten fasteners
Chain Clings to Sprocket Teeth	<ul style="list-style-type: none"> • Misalignment • Sprockets are worn out 	<ul style="list-style-type: none"> • Align shafts and sprockets • Replace sprockets
Chain Climbs the Sprocket Teeth	<ul style="list-style-type: none"> • Chain and/or sprockets worn out • Excessive slack • Extreme overload 	<ul style="list-style-type: none"> • Replace chain and/or sprockets • Adjust chain tension • Eliminate cause of overload
Rust on Chains	<ul style="list-style-type: none"> • Exposure to moisture • Water in lubricant • Inadequate lubrication 	<ul style="list-style-type: none"> • Use corrosion resistant chain • Change Lubricant. • Establish proper lubrication
Wear on one side of sprocket teeth	<ul style="list-style-type: none"> • Misalignment 	<ul style="list-style-type: none"> • Align shafts and sprockets
Chain is Stiff	<ul style="list-style-type: none"> • Misalignment • Inadequate lubrication • Corrosion • Excessive chain loads • Material build up in chain joint • Peening of link plate edges 	<ul style="list-style-type: none"> • Align shafts and sprockets • Provide proper lubrication • Use corrosion resistant chain • Resize the drive • Protect chain from foreign material • Remove obstruction
Link Plate Breakage	<ul style="list-style-type: none"> • Severe shock loading • Vibration • Pulsating drive conditions • Excessive chain loads 	<ul style="list-style-type: none"> • Reduce shock (Shock absorbers) • Install device to absorb vibration • too few sprocket teeth-resize drive • Resize the drive
Breakage of Pins, Bushings or Rollers	<ul style="list-style-type: none"> • Chain speed too high • Extreme overload • Severe shock loading • Corrosive damage • Material build-up in tooth pocket 	<ul style="list-style-type: none"> • Evaluate drive chain selection • Eliminate cause of overload • Reduce shock or use stronger shock resistant chain • Use corrosion resistant chain • Remove material and protect drive from foreign matter.

Product Index

Chain Number	Product Type	Inspire Series®	ULTRA-MAX®	HI-MAX®	Chain Number	Product Type	Inspire Series®	ULTRA-MAX®	HI-MAX®
05B	British Standard		134	150	12BMEGA II	Brit Std. Mega II Stainless			91
06B	British Standard	44	134	150	12B-2	British Standard	47	135	151
06BNP	British Std. Nickel Plate	73		158	12B-2FS-C	Brit Std Freedom Series®	101		
06BPCP II	Brit Std. Perfect Coat Plus II®	77			12B-2NP	Brit Std. Nickel Plate	73		
06BPS	Brit Std. Poly Steel			93	12B-2PCP II	Brit Std. Perfect Coat Plus II®	77		
06BSS	Brit Std 304 Stainless Steel	81		160	12B-2SS	Brit Std. 304 Stainless	8		
06B-2	British Standard	44	134	150	12B-2MEGA II	Brit Std. Mega II Stainless			91
06B-2NP	British Std. Nickel Plate				12BE-2	Brit Std. Thru Hardened Pin		141	
06B-2PCP II	Brit Std. Perfect Coat Plus II®				12B-3	British Standard	47	135	151
06B-2SS	Brit Std 304 Stainless Steel				12BE-3	Brit Std. Thru Hardened Pin		141	
06B-3	British Standard	44	134	150	16B	British Standard	48	135	151
08B	British Standard	45	134	150	16BE	Brit Std. Thru Hardened Pin		140	
08BF	Brit Std. Flat Side Bar	57	147	157	16BF	Brit Std. Flat Side Bar	57	147	157
08BFS-C	Brit Std. Freedom Series	101			16BFS-C	Brit Std Freedom Series®	101		
08BNP	British Std. Nickel Plate	73			16BNP	Brit Std. Nickel Plate	73		158
08BPCP II	Brit Std. Perfect Coat Plus II®	77		158	16BPCP II	Brit Std. Perfect Coat Plus II®	77		
08BPS	Brit Std. Poly Steel			93	16BSS	Brit Std. 304 Stainless	81		160
08BSS	Brit Std 304 Stainless Steel	81		160	16BMEGA II	Brit Std. Mega II Stainless			91
08BMEGA II	Brit Std. Mega II Stainless			91	16B-2	British Standard	48	135	151
08B-2	British Standard	45	134	150	16B-2FS-C	Brit Std Freedom Series®	101		
08B-2FS-C	Brit Std. Freedom Series	101			16B-2NP	Brit Std. Nickel Plate	73		
08B-2NP	British Std. Nickel Plate	73			16B-2PCP II	Brit Std. Perfect Coat Plus II®	77		
08B-2PCP II	Brit Std. Perfect Coat Plus II®	77			16B-2SS	Brit Std. 304 Stainless	81		
08B-2SS	Brit Std 304 Stainless Steel	81			16B-2MEGA II	Brit Std. Mega II Stainless			91
08B-2MEGA II	Brit Std. Mega II Stainless			91	16BE-2	Brit Std. Thru Hardened Pin		141	
08B-3	British Standard	45	134	150	16B-3	British Standard	48	135	151
10B	British Standard	46	134	150	16BE-3	Brit Std. Thru Hardened Pin		141	
10BE	Brit Std. Thru Hardened Pin		140		20B	British Standard	49	135	151
10BF	Brit Std. Flat Side Bar	57	147	157	20BE	Brit Std. Thru Hardened Pin		140	
10BFS-C	Brit Std. Freedom Series	101			20BF	Brit Std. Flat Side Bar	57	147	157
10BNP	British Std. Nickel Plate	73		158	20BFS-C	Brit Std Freedom Series®	101		
10BPCP II	Brit Std. Perfect Coat Plus II®	77			20BNP	Brit Std. Nickel Plate	73		
10BPS	Brit Std. Poly Steel			93	20BPCP II	Brit Std. Perfect Coat Plus II®	77		
10BSS	Brit Std 304 Stainless Steel	81		160	20B-2	British Standard	49	135	151
10BMEGA II	Brit Std. Mega II Stainless			91	20B-2FS-C	Brit Std Freedom Series®	101		
10B-2	British Standard	46	134	150	20B-2NP	Brit Std. Nickel Plate	73		
10B-2FS-C	Brit Std. Freedom Series	101			20B-2PCP II	Brit Std. Perfect Coat Plus II®	77		
10B-2NP	British Std. Nickel Plate	73			20BE-2	Brit Std. Thru Hardened Pin		141	
10B-2PCP II	Brit Std. Perfect Coat Plus II®	77			20B-3	British Standard	48	135	151
10B-2SS	Brit Std 304 Stainless Steel	81			20BE-3	Brit Std. Thru Hardened Pin		141	
10B-2MEAG II	Brit Std. Mega II Stainless			91	24B	British Standard	50	135	151
10B-3	British Standard	46	134	150	24BE	Brit Std. Thru Hardened Pin		140	
12B	British Standard	47	135	151	24BF	Brit Std. Flat Side Bar	57	147	157
12BE	Brit Std. Thru Hardened Pin		140		24B-2	British Standard	50	135	151
12BF	Brit Std. Flat Side Bar	57	147	157	24BE-2	Brit Std. Thru Hardened Pin		141	
12BFS-C	Brit Std. Freedom Series	101			24B-3	British Standard	50	135	151
12BNP	British Std. Nickel Plate	73		158	24BE-3	Brit Std. Thru Hardened Pin		141	
12BPCP II	Brit Std. Perfect Coat Plus II®	77			25	ASME/ANSI Standard	12	132	148
12BPS	Brit Std. Poly Steel			93	25F	ASME/ANSI Flat Side Bar		146	
12BSS	Brit Std 304 Stainless Steel	81		160	25NP	ASME/ANSI Nickel Plate	72		158

Product Index

Chain Number	Product Type	Inspire Series®	ULTRA-MAX®	HI-MAX®	Chain Number	Product Type	Inspire Series®	ULTRA-MAX®	HI-MAX®
25PS	ASME/ANSI Poly Steel			93	40SS600	ASME 600 Stainless		84	
25SS	ASME/ANSI 304 Stainless	80		160	40SSH	304 Stainless Hollow Pin	108		
25-2	ASME/ANSI Standard	12			40-2	ASME/ANSI Standard	18	132	148
25-3	ASME/ANSI Standard	12			40-2FS-C	Freedom Series® C-Type	100		
28B	British Standard	51	135	151	40-2NP	ASME/ANSI Nickel Plate	72		
28BE	Brit Std. Thru Hardened Pin		140		40-2PCP II	ANSI Perfect Coat Plus II®	76		
28BF	Brit Std Flat Side Bar	57	147		40-2SL	ASME/ANSI Self Lube	97		
28B-2	British Standard	51	135	151	40-2SS	ASME/ANSI 304 Stainless	80		
28BE-2	Brit Std. Thru Hardened Pin		141		40-2MEGA	ANSI /ASME Mega			89
28B-3	British Standard	51	135	151	40-2MEGA II	ANSI/ASME Mega II			90
28BE-3	Brit Std. Thru Hardened Pin		141		40-3	ASME/ANSI Standard	18	132	148
32B	British Standard	52	135	151	40-4	ASME/ANSI Standard	18		
32BE	Brit Std. Thru Hardened Pin		140		40-5	ASME/ANSI Standard	18		
32BF	Brit Std Flat Side Bar	57	147		40-6	ASME/ANSI Standard	18		
32B-2	British Standard	52	135	151	40B	British Standard		135	151
32BE-2	Brit Std. Thru Hardened Pin		141		40BE	Brit Std. Thru Hardened Pin		140	
32B-3	British Standard	52	135	151	40B-2	British Standard		135	151
32BE-3	Brit Std. Thru Hardened Pin		141		40BE-2	Brit Std. Thru Hardened Pin		141	
35	ASME/ANSI Standard	14	132	148	40B-3	British Standard		135	151
35F	ASME/ANSI Flat Side Bar	56	146		40BE-3	Brit Std. Thru Hardened Pin		141	
35NP	ASME/ANSI Nickel Plate	72		158	41	ASME/ANSI Standard	16	132	148
35PCP II	ANSI Perfect Coat Plus II®	76			41NP	ASME/ANSI Nickel Plate	72		
35PS	ASME/ANSI Poly Steel	93			41SS	ASME/ANSI 304 Stainless	80		
35SS	ASME/ANSI 304 Stainless	80		160	48B	British Standard		135	151
35SS600	ASME/ANSI 600 Stainless		84		48BE	Brit Std. Thru Hardened Pin		140	
35-2	ASME/ANSI Standard	14	132	148	48B-2	British Standard		135	151
35-2NP	ASME/ANSI Nickel Plate	72			48BE-2	Brit Std. Thru Hardened Pin		141	
35-2PCP II	ANSI Perfect Coat Plus II®	76			48B-3	British Standard		135	151
35-2SS	ASME/ANSI 304 Stainless	80			48BE-3	Brit Std. Thru Hardened Pin		141	
35-3	ASME/ANSI Standard	14	132	148	50	ASME/ANSI Standard	20	132	148
35-4	ASME/ANSI Standard	14			50 O-RING	ASME/ANSI O-Ring		103	
35-5	ASME/ANSI Standard	14			50CRP	ASME/ANSI Chrome Pin		53	
35-6	ASME/ANSI Standard	14			50E	ANSI Thru Hardened Pin		138	
40	ASME/ANSI Standard	18	132	148	50F	ASME/ANSI Flat Side Bar	56	146	156
40 O-RING	ASME/ANSI O-Ring		103		50FS	ANSI Freedom Series®	99		
40CRP	ASME/ANSI Chrome Pin		53		50FS-C	Freedom Series® C-Type	100		
40F	ASME/ANSI Flat Side Bar	56	146	156	50H	ANSI Heavy Series		136	152
40FS	ANSI Freedom Series®	99			50HE	Heavy Thru Hardened Pin		142	
40FS-C	Freedom Series® C-Type	100			50HP	ASME/ANSI Hollow Pin	106		
40HP	ASME/ANSI Hollow Pin	106			50NP	ASME/ANSI Nickel Plate	72		158
40NP	ASME/ANSI Nickel Plate	72		158	50PCP II	ANSI Perfect Coat Plus II®	76		
40PCP II	ANSI Perfect Coat Plus II®	76			50PS	ASME/ANSI Poly Steel			93
40PS	ASME/ANSI Poly Steel			93	50SB	ASME/ANSI Side Bow	70		
40SB	ASME/ANSI Side Bow	70			50SL	ASME/ANSI Self Lube	97		
40SL	ASME/ANSI Self Lube	97			50SLHP	ANSI Self Lube Hollow Pin	110		
40SLHP	ANSI Self Lube Hollow Pin	110			50SS	ASME/ANSI 304 Stainless	80		160
40SS	ASME/ANSI 304 Stainless	80		160	50MEGA	ANSI /ASME Mega			89
40MEGA	ANSI /ASME Mega			89	50MEGA II	ANSI/ASME Mega II			90
40MEGA II	ANSI/ASME Mega II			90	50SS316	ASME/ANSI 316 Stainless		86	
40SS316	ASME/ANSI 316 Stainless		86		50600	ASME/ANSI 600 Stainless		84	

Product Index

Chain Number	Product Type	Inspire Series®	ULTRA-MAX®	HI-MAX®	Chain Number	Product Type	Inspire Series®	ULTRA-MAX®	HI-MAX®
50SSHP	304 Stainless Hollow Pin	108			60-4	ASME/ANSI Standard	22		
50-2	ASME/ANSI Standard	20	232	148	60-5	ASME/ANSI Standard	22		
50-2FS-C	Freedom Series® C-Type	100			60-6	ASME/ANSI Standard	22		
50-2NP	ASME/ANSI Nickel Plate	72			65	ASME Rollerless Hoist	69		
50-2PCP II	ANSI Perfect Coat Plus II®	76			80	ASME/ANSI Standard	24	133	149
50-2SL	ASME/ANSI Self Lube	97			80 O-RING	ASME/ANSI O-Ring		103	
50-2SS	ASME/ANSI 304 Stainless	80			80CRP	ASME/ANSI Chrome Pin		53	
50-2MEGA	ANSI /ASME Mega			89	80DC	ASME Double Capacity	66		
50-2MEGA II	ANSI/ASME Mega II			90	80E	ANSI Thru Hardened Pin	60	138	
50-3	ASME/ANSI Standard	20	132	148	80F	ASME/ANSI Flat Side Bar	56	146	156
50-4	ASME/ANSI Standard	20			80FS	ANSI Freedom Series®	99		
50-5	ASME/ANSI Standard	20			80FS-C	Freedom Series® C-Type	100		
50-6	ASME/ANSI Standard	20			80H	ANSI Heavy Series	58	136	152
60	ASME/ANSI Standard	22	132	148	80HE	Heavy Thru Hardened Pin	62	142	
60 O-RING	ASME/ANSI O-Ring		103		80HP	ASME/ANSI Hollow Pin	106		
60CRP	ASME/ANSI Chrome Pin		53		80HSU	ASME Super Heavy	64		
60E	ANSI Thru Hardened Pin	60	138		80NP	ASME/ANSI Nickel Plate	72		
60F	ASME/ANSI Flat Side Bar	56	146	156	80PCP II	ANSI Perfect Coat Plus II®	76		
60FS	ANSI Freedom Series®	99			80QC	Quad Capacity	67		
60FS-C	Freedom Series® C-Type	100			80SB	ASME/ANSI Side Bow	70		
60H	ANSI Heavy Series	58	136	152	80SG	ASME Seal Guard®	105		
60HE	Heavy Thru Hardened Pin	62	142		80SL	ASME/ANSI Self Lube	97		
60HP	ASME/ANSI Hollow Pin	106			80SLHP	ANSI Self Lube Hollow Pin	110		
60NP	ASME/ANSI Nickel Plate	72		158	80SS	ASME/ANSI 304 Stainless	80		160
60PCP II	ANSI Perfect Coat Plus II®	76			80MEGA	ANSI /ASME Mega			89
60PS	ASME/ANSI Poly Steel			93	80MEGA II	ANSI/ASME Mega II			90
60SB	ASME/ANSI Side Bow	70			80SS316	ASME/ANSI 316 Stainless		86	
60SL	ASME/ANSI Self Lube	97			80SS600	ASME/ANSI 600 Stainless		84	
60SLHP	ANSI Self Lube Hollow Pin	110			80SSHP	304 Stainless Hollow Pin	108		
60SS	ASME/ANSI 304 Stainless	80		160	80SU	ASME/ANSI Super	64		
60MEGA	ANSI /ASME Mega			89	80TC	Triple Capacity	67		
60MEGA II	ANSI/ASME Mega II			90	80-2	ASME/ANSI Standard	24	133	149
60SS316	ASME/ANSI 316 Stainless		86		80-2FS-C	Freedom Series® C-Type	100		
60SS600	ASME/ANSI 600 Stainless		84		80-2NP	ASME/ANSI Nickel Plate	72		
60SSHP	304 Stainless Hollow Pin	108			80-2PCP II	ANSI Perfect Coat Plus II®	76		
60-2	ASME/ANSI Standard	22	132	148	80-2SL	ASME/ANSI Self Lube	97		
60-2FS-C	Freedom Series® C-Type	100			80-2SS	ASME/ANSI 304 Stainless	80		
60-2NP	ASME/ANSI Nickel Plate	72			80-2MEGA	ANSI /ASME Mega			89
60-2PCP II	ANSI Perfect Coat Plus II®	76			80-2MEGA II	ANSI/ASME Mega II			90
60-2SL	ASME/ANSI Self Lube	97			80-2SU	ASME/ANSI Super	65		
60-2SS	ASME/ANSI 304 Stainless	80			80E-2	ANSI Thru Hardened Pin	61	139	
60-2MEGA	ANSI /ASME Mega			89	80H-2	ANSI Heavy Series	59	137	153
60-2MEGA II	ANSI/ASME Mega II			90	80H-2SU	ASME/ANSI Super	65		
60E-2	ANSI Thru Hardened Pin	61	139		80HE-2	Heavy Thru Hardened Pin	63	143	
60H-2	ANSI Heavy Series	59	137	153	80-3	ASME/ANSI Standard	24	133	149
60HE-2	Heavy Thru Hardened Pin	63	143		80-3SU	ASME/ANSI Super	65		
60-3	ASME/ANSI Standard	22	132	148	80E-3	ANSI Thru Hardened Pin	61	139	
60E-3	ANSI Thru Hardened Pin	61	139		80H-3	ANSI Heavy Series	59	137	153
60H-3	ANSI Heavy Series	59	137	153	80HE-3	Heavy Thru Hardened Pin	63	143	
60HE-3	Heavy Thru Hardened Pin	63	143		80-4	ASME/ANSI Standard	24		

Product Index

Chain Number	Product Type	Inspire Series®	ULTRA-MAX®	HI-MAX®	Chain Number	Product Type	Inspire Series®	ULTRA-MAX®	HI-MAX®
80-5	ASME/ANSI Standard	24			120SU	ASME/ANSI Super	64		
80-6	ASME/ANSI Standard	24			120TC	Triple Capacity	67		
85	ASME Rollerless Hoist	69			120-2	ASME/ANSI Standard	28	133	149
100	ASME/ANSI Standard	26	133	149	120-2SU	ASME/ANSI Super	6		
100CRP	ASME/ANSI Chrome Pin		53		120E-2	ANSI Thru Hardened Pin	61	139	
100DC	ASME Double Capacity	66			120H-2	ANSI Heavy Series	59	137	153
100E	ANSI Thru Hardened Pin	60	138		120H-2SU	ASME/ANSI Super Heavy	65		
100F	ASME/ANSI Flat Side Bar	56	146	156	120HE-2	Heavy Thru Hardened Pin	63	143	
100FS	ANSI Freedom Series®	99			120-3	ASME/ANSI Standard	28	133	149
100FS-C	Freedom Series® C-Type	100			120-3SU	ASME/ANSI Super	65		
100H	ANSI Heavy Series	58	136	152	120E-3	ANSI Thru Hardened Pin	61	139	
100HE	Heavy Thru Hardened Pin	62	142		120H-3	ANSI Heavy Series	59	137	153
100HSU	ASME Super Heavy	64			120HE-3	Heavy Thru Hardened Pin	63	143	
100NP	ASME/ANSI Nickel Plate	72			120-4	ASME/ANSI Standard	28		
100PCP II	ANSI Perfect Coat Plus II®	76			120-5	ASME/ANSI Standard	28		
100QC	Quad Capacity	67			120-6	ASME/ANSI Standard	28		
100SG	ASME Seal Guard®	105			125	ASME Rollerless Hoist	69		
100SL	ASME/ANSI Self Lube	97			140	ASME/ANSI Standard	30	133	149
100SS	ASME/ANSI 304 Stainless	80			140CRP	ASME/ANSI Chrome Pin		53	
100SU	ASME/ANSI Super	84			140DC	ASME Double Capacity		66	
100TC	Triple Capacity	67			140E	ANSI Thru Hardened Pin	60	138	
100-2	ASME/ANSI Standard	26	133	149	140F	ASME/ANSI Flat Side Bar	56	146	
100-2SU	ASME/ANSI Super	65			140H	ANSI Heavy Series	58	136	152
100E-2	ANSI Thru Hardened Pin	61	139		140HE	Heavy Thru Hardened Pin	62	142	
100H-2	ANSI Heavy Series	59	137	153	140HSU	ASME/ANSI Super Heavy	64		
100H-2SU	ASME/ANSI Super Heavy	65			140QC	Quad Capacity	67		
100HE-2	Heavy Thru Hardened Pin	63	143		140SG	ASME Seal Guard®	105		
100-3	ASME/ANSI Standard	26	133	149	140SU	ASME/ANSI Super	64		
100-3SU	ASME/ANSI Super	65			140TC	Triple Capacity	67		
100E-3	ANSI Thru Hardened Pin	61	139		140-2	ASME/ANSI Standard	30	133	149
100H-3	ANSI Heavy Series	59	137	153	140-2SU	ASME/ANSI Super	65		
100HE-3	Heavy Thru Hardened Pin	63	143		140E-2	ANSI Thru Hardened Pin	61	139	
100-4	ASME/ANSI Standard	26			140H-2	ANSI Heavy Series	59	137	153
100-5	ASME/ANSI Standard	26			140H-2SU	ASME/ANSI Super Heavy	65		
100-6	ASME/ANSI Standard	26			140HE-2	Heavy Thru Hardened Pin	63	143	
105	ASME Rollerless Hoist	69			140-3	ASME/ANSI Standard	30	133	149
120	ASME/ANSI Standard	28	133	149	140-3SU	ASME/ANSI Super	65		
120CRP	ASME/ANSI Chrome Pin		53		140E-3	ANSI Thru Hardened Pin	61	139	
120DC	ASME Double Capacity	66			140H-3	ANSI Heavy Series	59	137	153
120E	ANSI Thru Hardened Pin	60	138		140HE-3	Heavy Thru Hardened Pin	63	143	
120F	ASME/ANSI Flat Side Bar	56	146		140-4	ASME/ANSI Standard	30		
120FS	ANSI Freedom Series®	99			140-5	ASME/ANSI Standard	30		
120FS-C	Freedom Series® C-Type	100			140-6	ASME/ANSI Standard	30		
120H	ANSI Heavy Series	58	136	152	160	ASME/ANSI Standard	32	133	149
120HE	Heavy Thru Hardened Pin	62	142		160CRP	ASME/ANSI Chrome Pin		53	
120HSU	ASME/ANSI Super Heavy	64			160DC	ASME Double Capacity	66		
120PCP	ANSI Perfect Coat Plus®	76			160E	ANSI Thru Hardened Pin	60	138	
120QC	Quad Capacity	67			160F	ASME/ANSI Flat Side Bar	56	146	
120SG	ASME Seal Guard®	105			160H	ANSI Heavy Series	58	136	152
120SL	ASME/ANSI Self Lube	97			160HE	Heavy Thru Hardened Pin		62	142

Product Index

Chain Number	Product Type	Inspire Series®	ULTRA-MAX®	HI-MAX®	Chain Number	Product Type	Inspire Series®	ULTRA-MAX®	HI-MAX®
160HSU	ASME/ANSI Super Heavy	64			200TC	Triple Capacity	67		
160QC	Quad Capacity	67			200-2	ASME/ANSI Standard	36	133	149
160SG	ASME Seal Guard®	105			200-2SU	ASME/ANSI Super	65		
160SU	ASME/ANSI Super	64			200E-2	ANSI Thru Hardened Pin	61	139	
160TC	Triple Capacity	67			200H-2	ANSI Heavy Series	59	137	153
160-2	ASME/ANSI Standard	32	133	149	200HE-2	Heavy Thru Hardened Pin	63	143	
160-2SU	ASME/ANSI Super	65			200-3	ASME/ANSI Standard	36	133	149
160E-2	ANSI Thru Hardened Pin	61	139		200-3SU	ASME/ANSI Super	65		
160H-2	ANSI Heavy Series	59	137	153	200E-3	ANSI Thru Hardened Pin	61	139	
160H-2SU	ASME/ANSI Super Heavy	65			200H-3	ANSI Heavy Series	59	137	153
160HE-2	Heavy Thru Hardened Pin	61	143		200HE-3	Heavy Thru Hardened Pin	63	143	
160-3	ASME/ANSI Standard	32	133	149	200-4	ASME/ANSI Standard	36		
160-3SU	ASME/ANSI Super	65			200-5	ASME/ANSI Standard	36		
160E-3	ANSI Thru Hardened Pin	61	139		200-6	ASME/ANSI Standard	36		
160H-3	ANSI Heavy Series	59	137	153	A208B	Brit Std. Double Pitch		144	
160HE-3	Heavy Thru Hardened Pin	63	143		A210B	Brit Std. Double Pitch		144	
160-4	ASME/ANSI Standard	32			A212B	Brit Std. Double Pitch		144	
160-5	ASME/ANSI Standard	32			A216B	Brit Std. Double Pitch		144	
160-6	ASME/ANSI Standard	32			240	ASME/ANSI Standard	38	133	149
180	ASME/ANSI Standard	34	133	149	240DC	ASME Double Capacity	66		
180CRP	ASME/ANSI Chrome Pin		53		240F	ASME/ANSI Flat Side Bar	56		
180DC	ASME Double Capacity		66		240QC	Quad Capacity	67		
180E	ANSI Thru Hardened Pin	60	138		240SG	ASME Seal Guard®	105		
180F	ASME/ANSI Flat Side Bar	56			240TC	Triple Capacity	67		
180H	ANSI Heavy Series	58	136	152	240-2	ASME/ANSI Standard	38	133	149
180HE	Heavy Thru Hardened Pin	62	142		240-3	ASME/ANSI Standard	38	133	149
180QC	Quad Capacity	67			240-4	ASME/ANSI Standard	38		
180SG	ASME Seal Guard®	105			240-5	ASME/ANSI Standard	38		
180TC	Triple Capacity	67			240-6	ASME/ANSI Standard	38		
180-2	ASME/ANSI Standard	34	133	149	AL422	ASME/ANSI AL Leaf Chain	113		162
180E-2	ANSI Thru Hardened Pin	61	139		BL423	ASME/ANSI BL Leaf Chain	115		163
180H-2	ANSI Heavy Series	59	137	153	BL434	ASME/ANSI BL Leaf Chain	115		163
180HE-2	Heavy Thru Hardened Pin	63	143		AL444	ASME/ANSI AL Leaf Chain	113		162
180-3	ASME/ANSI Standard	34	133	149	BL444	ASME/ANSI BL Leaf Chain	115		163
180E-3	ANSI Thru Hardened Pin	61	139		BL446	ASME/ANSI BL Leaf Chain	115		163
180H-3	ANSI Heavy Series	59	137	153	AL466	ASME/ANSI AL Leaf Chain	113		162
180HE-3	Heavy Thru Hardened Pin	63	143		BL466	ASME/ANSI BL Leaf Chain	115		163
180-4	ASME/ANSI Standard	34			AL522	ASME/ANSI AL Leaf Chain	113		162
180-5	ASME/ANSI Standard	34			BL523	ASME/ANSI BL Leaf Chain	115		163
180-6	ASME/ANSI Standard	34			BL534	ASME/ANSI BL Leaf Chain	115		163
200	ASME/ANSI Standard	36	133	149	AL544	ASME/ANSI AL Leaf Chain	113		162
200CRP	ASME/ANSI Chrome Pin		53		BL544	ASME/ANSI BL Leaf Chain	115		163
200DC	ASME Double Capacity		66		BL546	ASME/ANSI BL Leaf Chain	115		163
200E	ANSI Thru Hardened Pin	60	138		AL566	ASME/ANSI AL Leaf Chain	113		162
200F	ASME/ANSI Flat Side Bar	56			BL566	ASME/ANSI BL Leaf Chain	115		163
200H	ANSI Heavy Series	58	136	152	AL622	ASME/ANSI AL Leaf Chain	113		162
200HE	Heavy Thru Hardened Pin	62	142		BL623	ASME/ANSI BL Leaf Chain	115		163
200QC	Quad Capacity	67			BL634	ASME/ANSI BL Leaf Chain	115		163
200SG	ASME Seal Guard®	105			AL644	ASME/ANSI AL Leaf Chain	113		162
200SU	ASME/ANSI Super	64			BL644	ASME/ANSI BL Leaf Chain	115		163

Product Index

Chain Number	Product Type	Inspire Series®	ULTRA-MAX®	HI-MAX®	Chain Number	Product Type	Inspire Series®	ULTRA-MAX®	HI-MAX®
BL646	ASME/ANSI BL Leaf Chain	115		163	LL1644	ISO Brit Std. LL Leaf Chain	117		165
AL666	ASME/ANSI AL Leaf Chain	113		162	BL1646	ASME/ANSI BL Leaf Chain	116		164
BL666	ASME/ANSI BL Leaf Chain	115		163	AL1666	ASME/ANSI AL Leaf Chain	114		
AL822	ASME/ANSI AL Leaf Chain	113		162	BL1666	ASME/ANSI BL Leaf Chain	116		164
LL0822	ISO Brit Std. LL Leaf Chain	117		165	LL1666	ISO Brit Std. LL Leaf Chain	117		165
BL823	ASME/ANSI BL Leaf Chain	115		163	LL2022	ISO Brit Std. LL Leaf Chain	117		165
BL834	ASME/ANSI BL Leaf Chain	115		163	A2040	Double Pitch Transmission	54	144	154
AL844	ASME/ANSI AL Leaf Chain	113		162	C2040	Double Pitch Conveyor	55	145	155
BL844	ASME/ANSI BL Leaf Chain	115		163	C2040DC	Double Capacity	68		
LL0844	ISO Brit Std. LL Leaf Chain	117		165	C2040FS-C	Freedom Series® C-Type	102		
BL846	ASME/ANSI BL Leaf Chain	115		163	C2040HP	Hollow Pin	107		
AL866	ASME/ANSI AL Leaf Chain	113		162	C2040NP	Nickel Plated	74		159
BL866	ASME/ANSI BL Leaf Chain	115		163	C2040PCP II	Perfect Coat Plus II®	78		
LL0866	ISO Brit Std. LL Leaf Chain	117		165	C2040SB	Side Bow	70		
AL1022	ASME/ANSI AL Leaf Chain	114			C2040SL	Self Lube	98		
LL1022	ISO Brit Std. LL Leaf Chain	117		165	C2040SLHP	Self Lube Hollow Pin	111		
BL1023	ASME/ANSI BL Leaf Chain	116		164	C2040SS	304 Stainless Steel	82		161
BL1034	ASME/ANSI BL Leaf Chain	116		164	C2040SS316	316 Stainless Steel		87	
AL1044	ASME/ANSI AL Leaf Chain	114			C2040SS600	600 Stainless Steel		85	
BL1044	ASME/ANSI BL Leaf Chain	116		164	C2040SSHP	Stainless Steel Hollow Pin	109		
LL1044	ISO Brit Std. LL Leaf Chain	117		165	C2042	Double Pitch Conveyor	55	145	155
BL1046	ASME/ANSI BL Leaf Chain	116		164	C2042FS-C	Freedom Series® C-Type	102		
AL1066	ASME/ANSI AL Leaf Chain	114			C2042HP	Hollow Pin	107		
BL1066	ASME/ANSI BL Leaf Chain	116		164	C2042NP	Nickel Plated	74		159
LL1066	ISO Brit Std. LL Leaf Chain	117		165	C2042PCP II	Perfect Coat Plus II®	78		
AL1222	ASME/ANSI AL Leaf Chain	114			C2042SB	Side Bow	70		
LL1222	ISO Brit Std. LL Leaf Chain	117		165	C2042SL	Self Lube	98		
BL1223	ASME/ANSI BL Leaf Chain	116		164	C2042SLHP	Self Lube Hollow Pin	111		
BL1234	ASME/ANSI BL Leaf Chain	116		164	C2042SS	304 Stainless Steel	82		161
AL1244	ASME/ANSI AL Leaf Chain	114			C2042SS-D	Plastic Roller 304 Stainless	83		
BL1244	ASME/ANSI BL Leaf Chain	116		164	C2042SS316	316 Stainless Steel		87	
LL1244	ISO Brit Std. LL Leaf Chain	117		165	C2042SS600	600 Stainless Steel		85	
BL1246	ASME/ANSI BL Leaf Chain	116		164	C2042SSHP	Stainless Steel Hollow Pin	109		
AL1266	ASME/ANSI AL Leaf Chain	114			LL2044	ISO Brit Std. LL Leaf Chain	117		161
BL1266	ASME/ANSI BL Leaf Chain	116		164	A2050	Double Pitch Transmission	54	144	154
LL1266	ISO Brit Std. LL Leaf Chain	117		165	C2050	Double Pitch Conveyor	55	145	155
AL1422	ASME/ANSI AL Leaf Chain	114			C2050DC	Double Capacity	68		
BL1423	ASME/ANSI BL Leaf Chain	116		164	C2050FS-C	Freedom Series® C-Type	102		
BL1434	ASME/ANSI BL Leaf Chain	116		164	C2050HP	Hollow Pin	107		
AL1444	ASME/ANSI AL Leaf Chain	114			C2050NP	Nickel Plated	74		159
BL1444	ASME/ANSI BL Leaf Chain	116		164	C2050PCP II	Perfect Coat Plus II®	78		
BL1446	ASME/ANSI BL Leaf Chain	116		164	C2050SB	Side Bow	70		
AL1466	ASME/ANSI AL Leaf Chain	114			C2050SL	Self Lube	98		
BL1466	ASME/ANSI BL Leaf Chain	116		164	C2050SLHP	Self Lube Hollow Pin	111		
AL1222	ASME/ANSI AL Leaf Chain	114			C2050SS	304 Stainless Steel	82		161
LL1222	ISO Brit Std. LL Leaf Chain	117		165	C2050SS316	316 Stainless Steel	87	87	
BL1223	ASME/ANSI BL Leaf Chain	116		164	C2050SS600	600 Stainless Steel	85	85	
BL1234	ASME/ANSI BL Leaf Chain	116		164	C2050SSHP	Stainless Steel Hollow Pin	109		
AL1244	ASME/ANSI AL Leaf Chain	114			C2052	Double Pitch Conveyor	55	145	155
BL1644	ASME/ANSI BL Leaf Chain	116		164	C2052FS-C	Freedom Series® C-Type	102		

Product Index

Chain Number	Product Type	Inspire Series®	ULTRA-MAX®	HI-MAX®	Chain Number	Product Type	Inspire Series®	ULTRA-MAX®	HI-MAX®
C2052HP	Hollow Pin	107			C2080SLHP	Self Lube Hollow Pin	111		
C2052NP	Nickel Plate	74		159	C2080SSHP	Stainless Steel Hollow Pin	109		
C2052PCP II	Perfect Coat Plus II®	78			C2082H	Double Pitch Conveyor	55	145	155
C2052SB	Side Bow	70			C2082HFS-C	Freedom Series® C-Type	102		
C2052SL	Self Lube	98			C2082HNP	Nickel Plate	74		159
C2052SLHP	Self Lube Hollow Pin	111			C2082HP	Hollow Pin	107		
C2052SS	304 Stainless Steel	82		161	C2082HPCP II	Perfect Coat Plus II®	78		
C2052SS-D	Plastic Roller 304 Stainless	83			C2082HSS	304 Stainless Steel	82		161
C2052SS316	316 Stainless Steel		87		C2082HSS-D	Plastic Roller 304 Stainless	83		
C2052SS600	600 Stainless Steel		85		C2082HSS316	316 Stainless Steel		87	
C2052SSHP	Stainless Steel Hollow Pin	109			C2082HSS600	600 Stainless Steel		85	
A2060	Double Pitch Transmission	54	144	154	C2082SL	Self Lube	98		
C2060H	Double Pitch Conveyor	55	145	155	C2082SLHP	Self Lube Hollow Pin	111		
C2060HDC	Double Capacity	68			C2082SSHP	Stainless Steel Hollow Pin	109		
C2060HFS-C	Freedom Series® C-Type	102			C2100H	Double Pitch Conveyor	55	145	155
C2060HNP	Nickel Plate	74		159	C2100HDC	Double Capacity	68		
C2060HP	Hollow Pin	107			C2100HPCP II	Perfect Coat Plus II®	78		
C2060HPCP II	Perfect Coat Plus II®	78			C2100HSS	304 Stainless Steel	82		161
C2060HSS	304 Stainless Steel	82		161	C2102H	Double Pitch Conveyor	55	145	155
C2060HSS316	316 Stainless Steel		87		C2102HPCP II	Perfect Coat Plus II®	78		
C2060HSS600	600 Stainless Steel		85		C2102HSS	304 Stainless Steel	82		161
C2060SB	Side Bow	70			C2120H	Double Pitch Conveyor	55	145	155
C2060SL	Self Lube	98			C2120HDC	Double Capacity	68		
C2060SLHP	Self Lube Hollow Pin	111			C2120HPCP II	Perfect Coat Plus II®	78		
C2060SSHP	Stainless Steel Hollow Pin	109			C2120HSS	304 Stainless Steel	82		161
C2062H	Double Pitch Conveyor	55	145	155	C2122H	Double Pitch Conveyor	55	145	
C2062HFS-C	Freedom Series® C-Type	102			C2122HPCP II	Perfect Coat Plus II®	68		
C2062HNP	Nickel Plate	74		159	C2122HSS	304 Stainless Steel	82		
C2062HP	Hollow Pin	107			C2160H	Double Pitch Conveyor	55	145	
C2062HPCP II	Perfect Coat Plus II®	78			C2160HDC	Double Capacity	68		
C2062HSS	304 Stainless Steel	82		161	C2162H	Double Pitch Conveyor	55	145	
C2062HSS-D	Plastic Roller 304 Stainless	83			LL2422	ISO Brit Std. LL Leaf Chain	117		165
C2062HSS316	316 Stainless Steel		87		LL2444	ISO Brit Std. LL Leaf Chain	117		165
C2062HSS600	600 Stainless Steel		85		LL2466	ISO Brit Std. LL Leaf Chain	117		165
C2062SB	Side Bow	70			LL2822	ISO Brit Std. LL Leaf Chain	117		165
C2062SL	Self Lube	98			LL2844	ISO Brit Std. LL Leaf Chain	117		165
C2062SLHP	Self Lube Hollow Pin	111			LL2866	ISO Brit Std. LL Leaf Chain	117		165
C2062SSHP	Stainless Steel Hollow Pin	109			LL3222	ISO Brit Std. LL Leaf Chain	117		165
LL2066	ISO Brit Std. LL Leaf Chain	117		165	LL3244	ISO Brit Std. LL Leaf Chain	117		165
A2080	Double Pitch Transmission	54	144		LL3266	ISO Brit Std. LL Leaf Chain	117		165
C2080H	Double Pitch Conveyor	55	145	155					
C2080HDC	Double Capacity	68							
C2080HFS-C	Freedom Series® C-Type	102							
C2080HNP	Nickel Plate	74		159					
C2080HP	Hollow Pin	107							
C2080HPCP II	Perfect Coat Plus II®	78							
C2080HSS	304 Stainless Steel	82		161					
C2080HSS316	316 Stainless Steel		87						
C2080HSS600	600 Stainless Steel		85						
C2080SL	Self Lube	98							

Terms and Conditions of Sale

1. Price and Payment Terms:

- (a) All prices set forth herein are FOB Seller's Shipping point and are payable net thirty (30) days after invoice date. A one percent (1%) cash discount from net invoice price (exclusive of all other charges) will apply to payments received within ten (10) days of invoice date. Shipments will be invoiced as of date of shipment. Accounts not paid within thirty (30) days of invoice date will bear interest from the invoice date at the rate of one and one-half percent (1-1/2%) per month or the maximum rate allowed by law, whichever is less. In the event of failure of timely payment by Buyer, shall pay to Seller all costs of collection, including fifteen percent (15%) of the amount due hereunder as attorney's fees if collected by or through an attorney-at-law.
- (b) Prices on the goods are exclusive of all city, state, and federal excise taxes, including, without limitation, taxes on manufacture, sales, receipts, gross income, occupation, use and similar taxes. Wherever applicable, any tax or taxes will be added to the invoice as a separate charge to be paid by the Buyer.
- (c) In addition to the purchase price for the goods Buyer shall pay and be liable for all expenses incurred by Seller for insurance, freight, cartage, warehousing, and all other charges in connection with loading and shipping the goods to the Buyer. Seller will exercise reasonable efforts to route shipments to incur the lowest available transportation charges; any premium rate shipping shall be at the request and cost of Buyer.
- (d) The minimum net invoice charge on any order shall be \$100.00.
- (e) Payment for the goods shall, if Seller so requires, be made in full prior to delivery and Seller shall be entitled to withhold delivery until such payment has been made and any check or other negotiable instrument given in payment has cleared. Seller shall have the additional right at any time to limit or cancel any credit extended or to be extended hereunder. Upon failure by Buyer to make payment to Seller within thirty (30) days after notice from Seller limiting or cancelling any credit extended or requiring Buyer to make payment before delivery, Seller shall have the option to cancel this and other contracts between Seller and Buyer.
- (f) Prices are subject to change without notice. The price for an order will be the price in effect at the time of shipment.

2. Title to and Reservation of Security Interest in the Goods:

Until Buyer has completed payment for the goods, title and ownership to said goods shall remain with Seller and its assigns. In the event it is determined that, contrary to the foregoing, title has transferred prior to full payment, Seller hereby reserves and Buyer hereby grants to Seller a purchase money security interest in the goods.

3. Limitation Of Warranty, Remedy and Liability:

- (a) Seller warrants the goods to be free from defects in workmanship and/or materials for a period of ninety (90) days from the date of shipment to Buyer. Seller or its authorized distributor must receive written notice of any warranty claim within two weeks of the date that the defect should have been discovered. To claim under this warranty, goods must be returned to Seller, freight prepaid by Buyer, for determination by Seller that such goods are defective because of poor workmanship or defective materials. Seller shall replace or repair, at its sole option and expense, any defective goods or parts thereof, and return such repaired/replacement material to Buyer, freight prepaid by Seller. **THIS REMEDY IS THE SOLE AND EXCLUSIVE REMEDY AVAILABLE TO BUYER.** If Seller determines in its sole discretion that the defect is attributable to any cause other than poor workmanship or defective materials (including, but not limited to, misuse or abusive operation, faulty installation, unauthorized repair), then Seller shall have no obligation whatsoever with respect to repair or replacement of the defective goods. Seller shall return the goods to Buyer, freight to be paid by Buyer, and the warranty described herein shall be void.
- (b) All specifications, performance figures, drawings, and particulars of weights and dimensions made available by Seller and not included in this warranty are approximate only and the descriptions and illustrations contained in Seller's catalogs, price lists, or sales material are intended only to present a general idea of their subject matter, and none of the items referred to above shall form part of this warranty. Recommendations for the use of the goods are suggestions only and not directions and Seller makes no express or implied warranties with respect thereto.
- (c) EXCEPT AS NOTED IN PARAGRAPH (a), THERE IS NO WARRANTY OF MERCHANTABILITY OR OF FITNESS FOR A PARTICULAR PURPOSE OR ANY OTHER WARRANTY BY SELLER, EITHER EXPRESS OR IMPLIED.
- (d) BUYER AGREES THAT NO OTHER REMEDY (INCLUDING, BUT NOT LIMITED TO, PUNITIVE, EXEMPLARY, INCIDENTAL OR CONSEQUENTIAL DAMAGES FOR LOST PROFITS, LOST SALES, OR, INCIDENTAL OR CONSEQUENTIAL LOSS) IN CONNECTION WITH THE USE, PURCHASE, NON-USE OR OPERATION OF THE GOODS SHALL BE AVAILABLE TO IT UNDER ANY CIRCUMSTANCES, WHETHER BASED UPON NEGLIGENCE OR OTHERWISE AND IRRESPECTIVE OF WHETHER SELLER HAS BEEN ADVISED OF THE POSSIBILITY OF ANY SUCH DAMAGES. IN ANY EVENT, THE LIABILITY OF SELLER TO BUYER FOR ANY REASON AND UPON ANY CAUSE OF ACTION WHATSOEVER SHALL BE LIMITED TO THE AMOUNT THEN PREVIOUSLY PAID TO SELLER BY BUYER.

4. Return of Goods/Cancellation:

Once placed, orders may not be cancelled without the seller's consent. The seller may, at its sole discretion, accept returns of standard materials for credit. In this case the buyer shall obtain a RETURNED GOODS AUTHORIZATION (RGA) from the seller. No returns, of any kind, will be accepted by the seller, without a valid RGA. A copy of the RGA for shall be enclosed by the buyer with the shipment of authorized returned products to the seller. Goods returned for credit must be returned FREIGHT PREPAID to the seller's location. Such goods must also be in a resalable condition and are subject to a 20% restocking fee. Goods returned for warranty claim also require a valid RGA and must follow the shipping procedure detailed above. For additional information on how to file a warranty claim see "Limitation of Warranty, Remedy, and Liability" in our "Terms and Conditions of Sale".

5. Delay or Nonperformance:

Seller shall not be liable for delay in shipment for any cause beyond its reasonable control, nor shall such delay entitle Buyer to cancel any order or refuse to accept delivery. Seller shall not be liable for failure or delay in shipment or other performance hereunder if such failure is due in whole or in part to strikes, fires, accidents, wars; rebellions, civil commotion or public strike, acts of any government, whether legal or otherwise, acts of public enemies, force majeure, inability to secure or obtain or delay in securing or obtain transportation, machinery, materials, or sufficient qualified labor, or any other causes beyond Seller's reasonable control. Claims for shortage, damage or nondelivery shall be made directly to carrier, and request for proof of delivery must be made within ninety (90) days of invoice date.

6. Risk of Loss:

Unless otherwise specifically agreed in writing, risk of loss of the goods shall pass from Seller to Buyer when the goods or any portion thereof, property packed and secured in such a manner as to reach their destination in good condition under normal conditions of transport, are placed in the possession of the carrier, FOB Seller's shipping point for shipment to Buyer. The Seller may choose any reasonable carrier for delivery. Tender of delivery shall be deemed made at Seller's shipping point even when freight is prepaid to point of destination or Seller is required to deliver the goods to a particular destination.

7. Modifications:

This document constitutes the entire agreement of the parties with respect to the terms and conditions of sale of the goods. No modification of this document shall be binding upon Seller unless in writing and signed by the party to be bound. Any terms and provisions contained in any document of Buyer which are inconsistent with the terms and provisions hereof shall not be binding on Seller and shall not be considered applicable to the sale or shipment of the goods. No agent, employee, or representative of Seller other than its Officers has any authority to bind Seller to any affirmation, representation or warranty concerning the goods sold under this document and unless an affirmation, representation or warranty made by an Officer of Seller is specifically included in this document, it has not formed a part of the basis of this bargain and shall not in any way be enforceable.

8. Waiver:

A waiver by Seller of a breach by Buyer of any provision of this document shall not be deemed a waiver of future compliance with the provision of the document breached.

9. Controlling Law:

The validity and interpretation of this document shall be governed by the laws of the State of Georgia.

10. Jurisdiction:

Buyer, to the extent it may lawfully do so, hereby submits to the jurisdiction of any state or federal court located in Cobb County, Georgia as well as to the jurisdiction of all courts from which an appeal may be taken from the aforesaid courts for the purpose of any suit, action or other proceeding arising out of any of the Buyer's obligations under or with respect to this document, and the Buyer expressly waives any and all objections that Buyer may have as to jurisdiction and/or venue in any of such courts.

11. Special Order Goods:

On special order goods, Buyer will indemnify and hold Seller harmless from all costs and damages arising out of any intellectual property infringement claim relating to any goods manufactured by Seller pursuant to the designs or specifications furnished by Buyer as well as any claims arising out of or connected with an end product into which goods sold by Seller are incorporated, including but not limited to any claims relating to product liability, breach of warranty, breach of contract or otherwise.

Attachment Spacing Line Drawing

