



**Corporate Headquarters
East Coast Service Center:**

MAXCO CHAIN
1245 Kennestone Circle
Marietta, GA 30066
TEL: 800-241-8209
TEL: 770-424-9350
FAX: 770-424-9145

West Coast Service Center:

MAXCO CHAIN
3529 NW Yeon Ave.
Portland, OR 97210
TEL: 800-544-7943
TEL: 503-228-6828
FAX: 503-228-6703

Web Site: www.maxcochain.com

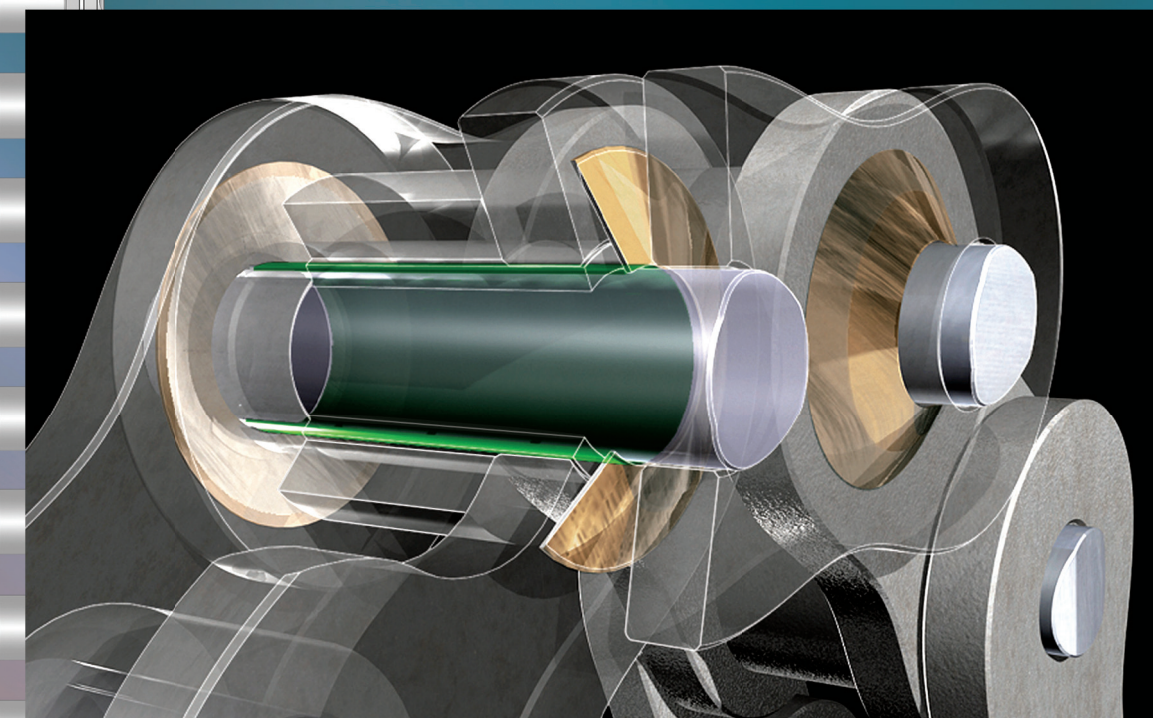

IMPROVED WEAR LIFE

SEALED JOINTS

KEEPS LUBRICANT IN

KEEPS ABRASIVE MATERIAL OUT



Maintenance Free Operation now possible for Heavy Duty Roller Chain Drives

Newly developed, patent pending; SEAL GUARD™ Roller Chains from MAXCO CHAIN extend the benefits of maintenance free operation to larger pitch heavy duty roller chain drives.

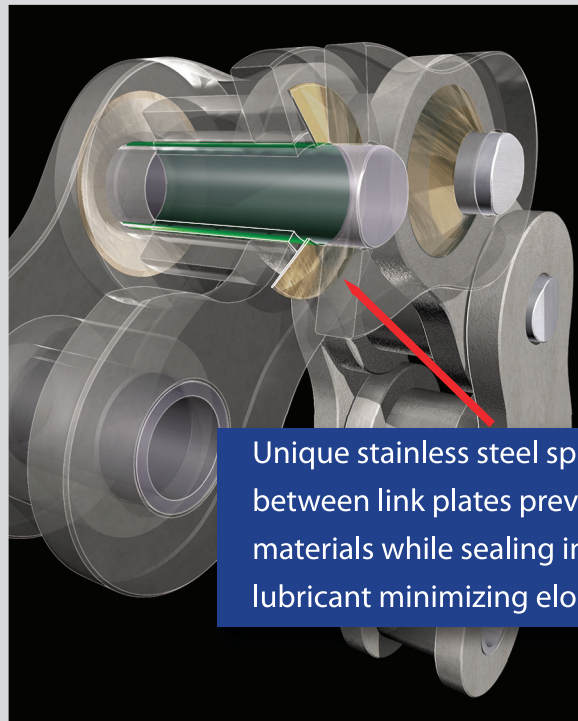

Construction, mining, shot blast equipment, as well as a broad range of heavy duty roller chain applications can now utilize large pitch roller chain - Sizes 60 (3/4" pitch) thru 240 (3" pitch) and enjoy the significant benefits of maintenance free operation. The unique stainless steel contact seals, installed between the link plates, retains a high quality bearing grease inside the chain joint, keeping out damaging abrasives such as grit and other debris that decrease chain life.

Unique stainless steel spring type contact seals fitted between link plates prevent penetration of abrasive materials while sealing in high quality bearing lubricant minimizing elongation due to chain wear

These chains never require continuous lubrication, possess the same strength and working load capability as standard duty roller chain and will operate over a wider range of temperatures and speeds. Stainless steel seals are more durable than conventional O-Rings and the lubrication benefits of the internal bearing grease offer superior lubrication over other similar types of maintenance free chains.

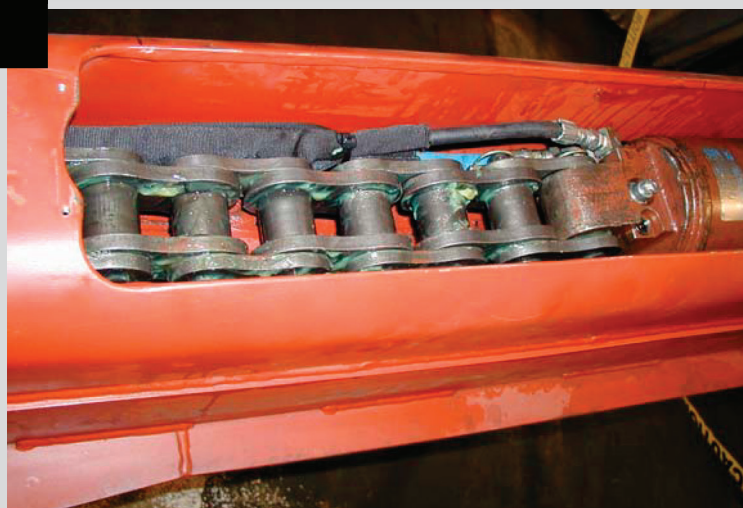

SEAL GUARD™ Roller Chains are available with a variety of corrosion resistant coatings. Our unique Inspire Series™ stainless steel blast coating is standard finish, optional black oxide or our Perfect Coat PlusII® surface treatments offer significant added protection against external chain corrosion.

Solid Solutions....Our premium solid bushing-solid roller design provides maximum service life in a wide variety of challenging and demanding applications.

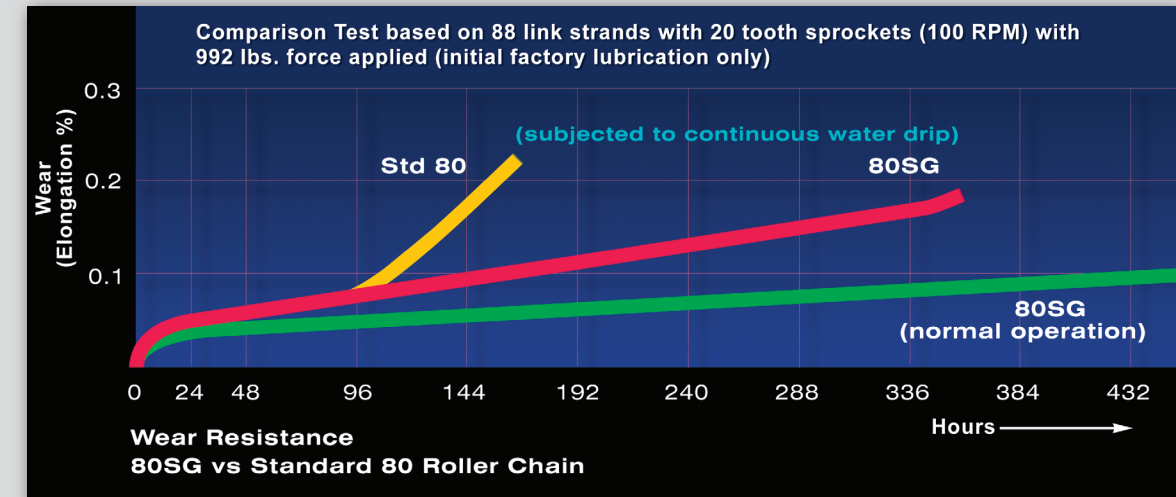

Proven design thoroughly tested in harsh and punishing environments.

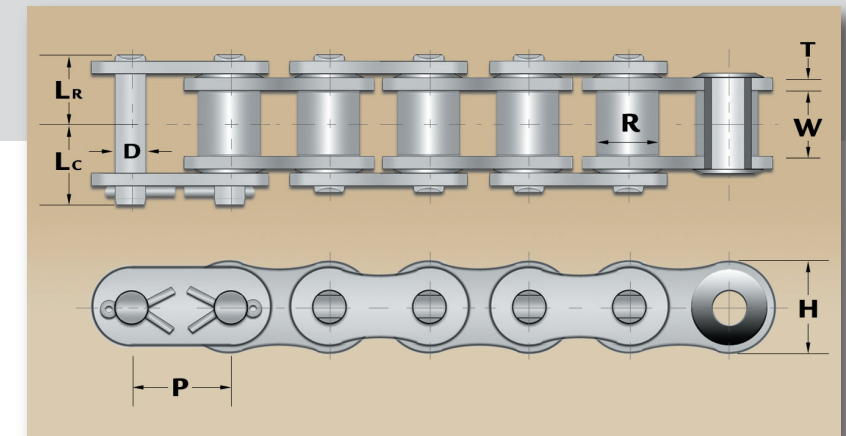

Seal Guard Roller Chain

Sizes are given in inches

Chain Number	Chain Pitch	Inside Width	Roller Dia.	Pin Dia.	Link Plate Thickness	Link Plate Height	Riveted Pin Length	Cottered Pin Length	Rated Working Load	Average Ultimate Strength	Average Chain Weight
	P	W	R	D	T	H	Lr	Lc	(Lbs.)	(Lbs.)	(Lbs.)
60SG	3/4	0.500	0.469	0.234	0.094	0.691	0.55	0.60	2,470	9,900	1.00
80SG	1	0.625	0.625	0.312	0.125	0.921	0.69	0.79	4,140	17,600	1.75
100SG	1-1/4	0.750	0.750	0.375	0.156	1.154	0.82	0.96	6,360	26,400	2.65
120SG	1-1/2	1.000	0.875	0.437	0.188	1.382	1.02	1.17	8,540	39,000	3.90
140SG	1-3/4	1.000	1.000	0.500	0.219	1.610	1.11	1.28	11,310	50,900	5.10
160SG	2	1.250	1.125	0.562	0.250	1.839	1.31	1.48	14,900	63,200	6.60
180SG	2-1/4	1.406	1.406	0.687	0.281	2.067	1.52	1.71	16,600	81,500	9.10
200SG	2-1/2	1.500	1.562	0.781	0.312	2.354	1.62	1.95	18,600	105,500	11.40
240SG	3	1.875	1.875	0.937	0.375	2.768	1.97	2.27	25,400	152,000	15.90

Specifications subject to change without notice